

Washington University in St. Louis

## Washington University Open Scholarship

---

Mechanical Engineering and Materials Science  
Independent Study

Mechanical Engineering & Materials Science

---

5-9-2023

### Accessible Computer Interface Device

Oliver Reid

*Washington University in St. Louis*

Follow this and additional works at: <https://openscholarship.wustl.edu/mems500>

---

#### Recommended Citation

Reid, Oliver, "Accessible Computer Interface Device" (2023). *Mechanical Engineering and Materials Science Independent Study*. 229.

<https://openscholarship.wustl.edu/mems500/229>

This Final Report is brought to you for free and open access by the Mechanical Engineering & Materials Science at Washington University Open Scholarship. It has been accepted for inclusion in Mechanical Engineering and Materials Science Independent Study by an authorized administrator of Washington University Open Scholarship. For more information, please contact [digital@wumail.wustl.edu](mailto:digital@wumail.wustl.edu).



**Spring 2023 MEMS 400 Independent Study**

Accessible Computer Input Device

Instructor: Dr. Jackson Potter

Student: Oliver Reid

**ABSTRACT:** Dr. Betsy Hawkins-Chernof is an Occupational Therapist in the St. Louis area and part of her work is helping individuals with disabilities access online gaming communities. Accessible gaming technology can be expensive and frequently out of stock which creates additional barrier for these individuals to access gaming communities. During the Fall 2022 MEMS 312 course, Dr. Potter helped develop a printed circuit board (PCB) that maps keyboard inputs and other computer functions to accessible switches. The goal of this independent study was to develop a 3D printable housing for the PCB that would have easily interchangeable chips to swap out the switch functions. Utilizing feedback from Dr. Betsy and the assistive technology innovation manager at St. Louis Arc, Chris Helmick, a fully functional and easily repeatable design was completed. This Accessible Computer Device was entered into the 2023 Make:able challenge as a unique solution to providing affordable access to computers. The challenge will provide an additional opportunity for the device to gain both feedback and exposure in hopes it will reach the people whose lives it could improve.

## **INTRODUCTION**

Online gaming provides individuals with disabilities a unique opportunity to join and partake in communities where they won't be limited by their disability. To access these online gaming communities however, they require more adaptable technology that allows the user to shape the function of the technology to their very specific and unique needs. This gaming technology is far less common than traditional controllers making it harder to come by and traditionally much more expensive. This is a serious deterrent in these people accessing online communities and deserves more attention and innovation.

One of the most common methods of providing more adaptable computer capabilities is using accessible buttons and switches. These switches can be positioned where they will be the most comfortable and convenient for the user and cater to their specific abilities. These switches need an interface device to communicate with the computer, however. Switches are relatively affordable and abundant, but these interface devices can be expensive and hard to come by.

The [Quester Switchbox](#) is a good example of one of these computer interface devices.

Figure 1 below shows the Quester Switchbox with its 6 switch ports.

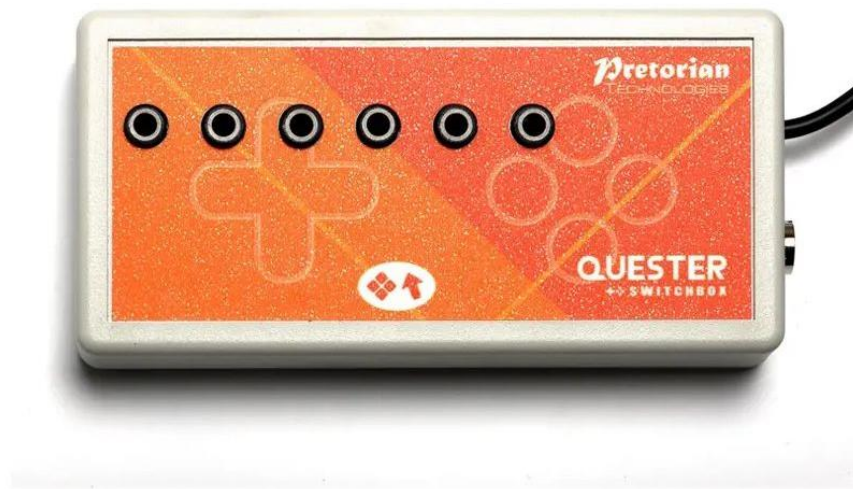

**Figure 1** Quester Switchbox computer interface device

This device allows the users to use accessible switches to play video games on their computer, but this device has its own flaws. One of the largest draw backs of the Quester Switchbox is its price point. This device costs just barely under \$150 before shipping, making it expensive enough to make you think twice before purchasing. The second large drawback of this device is the flexibility of its switch functions. This Switchbox has four levels of functions that the user can navigate between, but the first three levels have fixed functions. Only the fourth

level allows you to customize the function of each of the 6 ports. In this way, the Quester Switchbox is not very adaptive to the specific needs of the user.

Another example of an available computer switch interface is the [Microsoft Adaptive Hub](#). The Adaptive Hub can be seen in Figure 2 below.



**Figure 2 Microsoft Adaptive Hub**

The Adaptive hub can connect to assistive devices wirelessly as well as wired switches through its five 3.5 mm ports. The Adaptive Hub has a rechargeable battery so you can connect it to your computer wirelessly or through a wired connection. The Adaptive Hub is more affordable at \$60, but there are still areas in which it could be improved. The Adaptive Hub is very convenient once the switches have been programmed to the desired functionality, but quickly altering their functionality is not an option. In many users' cases they would need someone to reprogram the Adaptive Hub for them whenever they needed the functions modified.

Conversations with Dr. Hawkins-Chernof made it clear that there was a need for a more affordable and adaptive computer interface device. During the Fall 2022 session of MEMS 312, Dr. Potter developed the PCB board whose layout and schematic are shown in Figures 3 and 4 below.

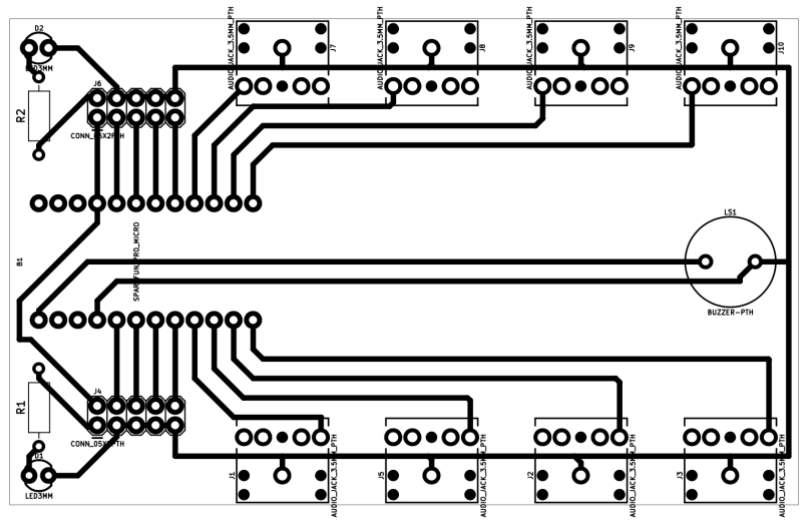

Figure 3 MEMS 312 PCB layout developed by Dr. Potter

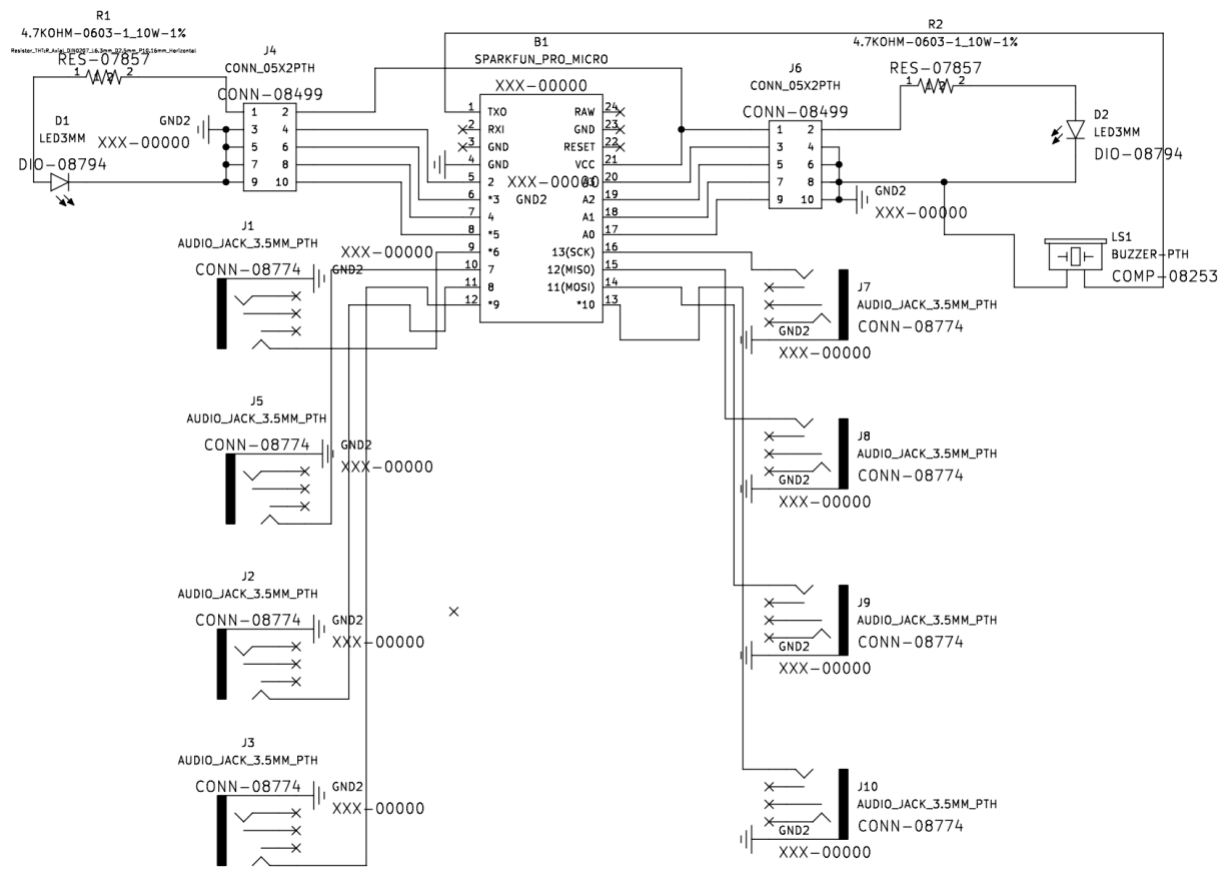

Figure 4 MEMS 312 PCB schematic

Table 1 below contains the components that must be soldered to the PCB, where they were purchased, and their respective costs.

**Table 1 PCB soldering components and costs**

Component	Cost	Source Purchased From
Printed Circuit Board	\$6	JLPCB
Audio Jacks	\$13	<a href="https://www.sparkfun.com/products/8032">https://www.sparkfun.com/products/8032</a>
Pro Micro 5V	\$19.50	<a href="https://www.sparkfun.com/products/12640">https://www.sparkfun.com/products/12640</a>
Buzzer	\$2.95	<a href="https://www.sparkfun.com/products/20660">https://www.sparkfun.com/products/20660</a>
Double-Row Male Headers	\$1.05	<a href="https://www.sparkfun.com/products/12791">https://www.sparkfun.com/products/12791</a>
Female Headers	\$1.75	<a href="https://www.sparkfun.com/products/115">https://www.sparkfun.com/products/115</a>
2-Pin Shunt/Jumper	\$0.10/piece	<a href="https://www.digikey.com/en/products/detail/sullins-connector-solutions/SPC02SYAN/76375">https://www.digikey.com/en/products/detail/sullins-connector-solutions/SPC02SYAN/76375</a>

The sum of the costs of the components in Table 1 above is approximately \$47. Once these components have all been soldered to the PCB the result can be seen in Figure 5 below.

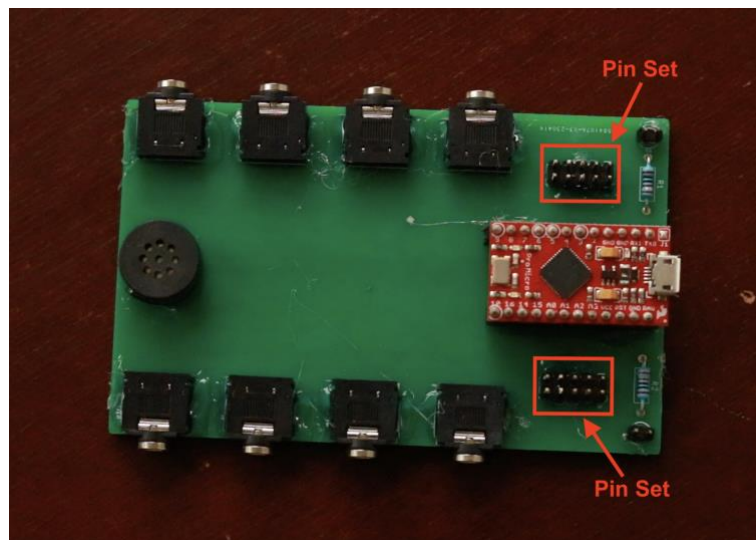

**Figure 5 Assembled PCB developed by Dr. Potter**

The PCB has eight total switch input ports, four on each side. The set of five pins on either side of the PCB are what dictate the function of the switches. The five sets of pins and their labeling can be seen in Figure 6 below.

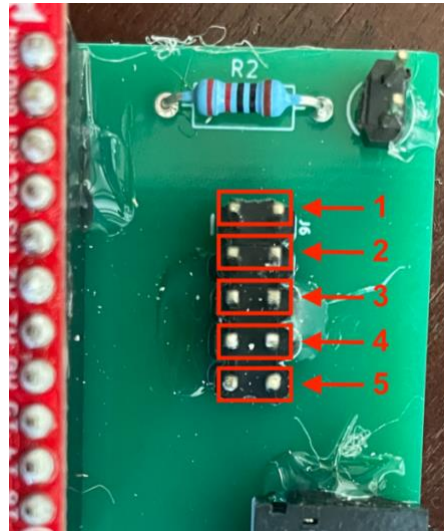

**Figure 6 PCB pin location and labeling**

The different combination of pins with jumpers connecting them is programmed to different sets of computer inputs. The pins have small jumpers inserted onto them to connect between them. This method for making connections between the pins is shown in Figure 7 below where the first and third sets of pins have jumpers inserted on them.

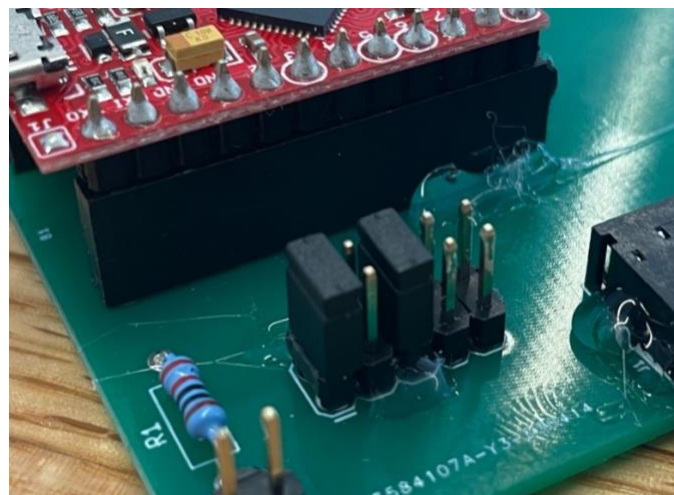

**Figure 7 Pin jumper method**







One set for example will control the up, down, right, and left movements of the mouse. Another set will control the WASD computer keys. The current list of PCB functions and their corresponding pins can be seen in Table 2 below.

**Table 2      PCB switch inputs and corresponding jumpers**

<b>Computer Function</b>	<b>Switch Inputs</b>	<b>Jumper Pins</b>
Mouse Movement (Linear)	Left, Up, Down, Right	1 and 2
Mouse Movement (Ramp)	Left, Up, Down, Right	1 and 3
Mouse Commands	Left click, Scroll up, Scroll down, Right Click	1 and 4
Arrow Keys	Left, Up, Down, Right	1 and 5
WASD Keys	A, W, S, D	1, 2, and 3
Utility Keys	Escape, Spacebar, Backspace, Enter	1, 2, and 4

The recommended labeling to keep the different key functions from Table 2 organized can be seen in Table 3 below.

**Table 3 Recommended key labeling**

Computer Function	Recommended Labeling				
Mouse Movement (Linear)		↓	←	→	↑
Mouse Movement (Ramp)		↓	←	→	↑
Mouse Commands		LC	↶	↷	RC
Arrow Keys		↓	↑	→	←
WASD Keys	WASD	A	W	S	D
Utility Keys	UTIL	esc	SPB	BSP	Ent

To securely hold the pins and keep the chip in place the PCB requires at least two sets of the pins to be jumped. This means that with 5 available pins there are 26 possible combinations giving an enormous amount of flexibility in how the user can control their computer. Once the PCB has been programmed, the pins jumped just need to be changed to change the functionality of the inserted switches. The board will detect when no pins are jumped vs when pins are jumped and plays one sound to notify the user when a chip has been inserted and a second sound when removed.

One of the primary purposes of this independent study was to design a chip that would hold the jumpers and make it easy to interchange the functions of the PCB. The challenging factor in this chip design is that it must have a geometry that allows even individuals with poor motor skills to remove and insert the chips. Once the chip design was complete it then had to be integrated into a 3D printable housing for the PCB that would protect it without limiting any of its functionality.

## **DESIGN PROCESS AND RESULTS**

The design process was divided into three basic sections, the chip design, the PCB housing design, and then integrating the chip design into the housing. The chip design was the first portion of the design tackled because the geometry of the chip is so important to ensuring the users can easily swap the functions of the switches. This took many iterations before a functional chip geometry was settled on. The housing design was simpler because it just required measuring the dimensions of the PCB to ensure the housing would snugly fit around all the components. Integrations took longer than expected due to lots of small interference issues that required troubleshooting. All of the sketching for this design process was performed on an iPad, and the entire CAD project was performed using Fusion 360 which is what allowed it to be entered in the Make:able challenge once it was completed.

The chips design was challenging but very engaging while searching for the geometry that would allow the easiest interchanging of the pins. Dr. Potter recommended using a triangular cross section, like a Toblerone chocolate bar, to help the chip guide itself into the slot. This turned out to be a very functional cross section and the had sketch and CAD of the first attempted chip design can be seen in Figures 8 and 9 below.

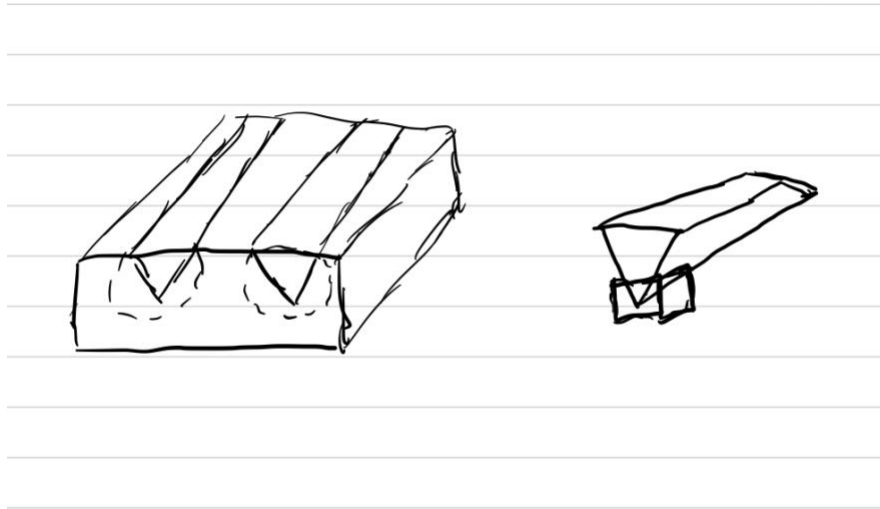

**Figure 8** Sketch of initial chip conceptualization

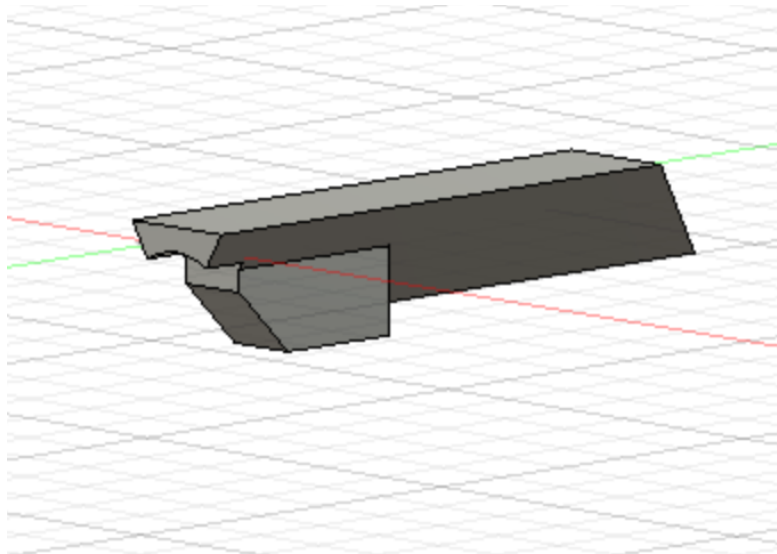

**Figure 9** CAD image of the original chip design

The chip had a slanted end to allow it to snugly fit under an overhand on the housing to help secure the chip once it had been inserted. The idea was that the pointed end of the chip could be inserted first and then used to guide the rest of the chip down. After printing the chip however, we realized that using that strategy didn't press the jumpers onto the pins going directly downwards which put stresses on the front pins and had the tendency to bend them out of shape.

The design was shifted to account for the need to press the chip directly down instead of using one end as a lever. The progression of the chip geometry can be seen in figure 10 below.

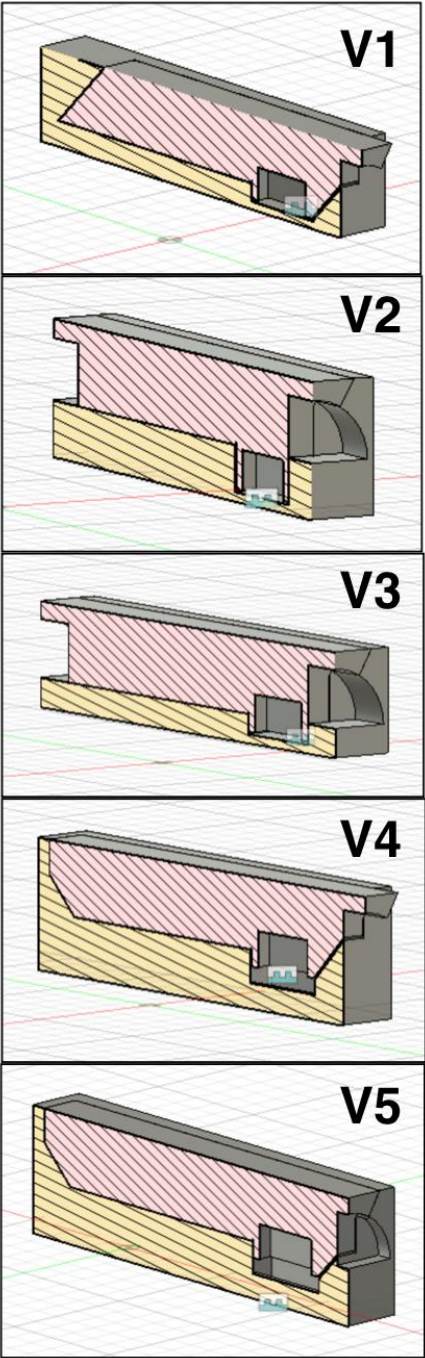

**Figure 10** Chip geometry progression

After five iterations and feedback from Dr. Hawkins-Chernof, the final chip design shown in Figure 11 below was finalized.

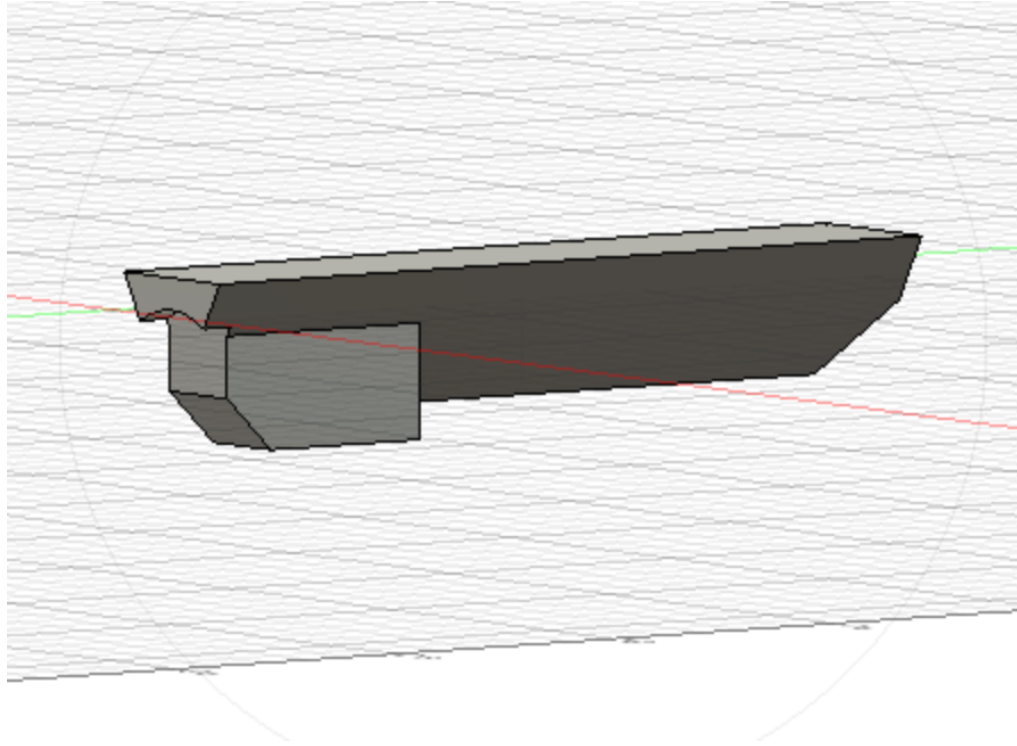

**Figure 11 CAD image of the finalized chip design**

The geometry of this chip allowed it to easily be set on top of the groove and pressed down with one hand into its slot. Similar to the reasoning behind the triangular cross section, both ends of the chip were angled inwards to help guide the chip into the correct position when pushed down on.

The housing design was much simpler than the chip because it only required the accurate measuring of the PCB's dimensions. Once the dimensions were recorded a housing that fit around them and held it secure didn't take very many iterations to complete. Determining a wall thickness that allowed access to all the ports without being flimsy was the most challenging part. The CAD of the final housing before integrating the chip design can be seen in Figure 12 below.

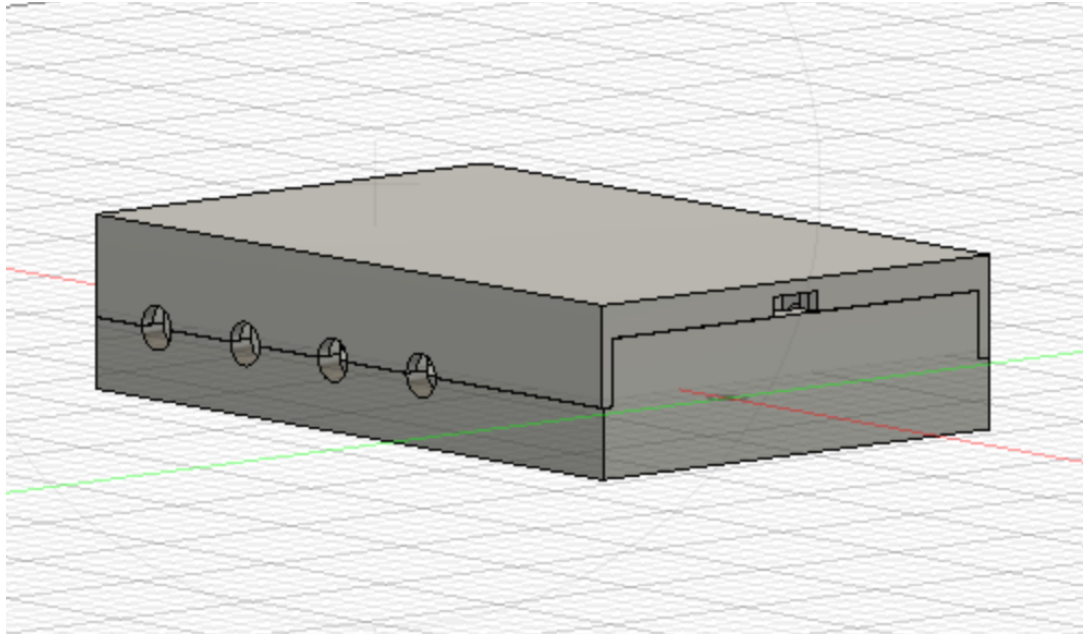

**Figure 12** CAD image of the finalized housing without chip

The final step in the design was to integrate the chip design with the housing. Creating the chip slot where it perfectly aligned with the pin locations of the PCB was very challenging but once they were aligned the rest of the integration went fairly smoothly. Small chamfers were made around the 3.5 mm switch ports, and a deep recess was required to allow the micro-USB to be plugged into the PCB. The final housing with the chip design integrated can be seen in figure 13 below. The following three pages contain drawings of the housing cap and housing base.



**Figure 13A** Front view of final housing with chip design integrated

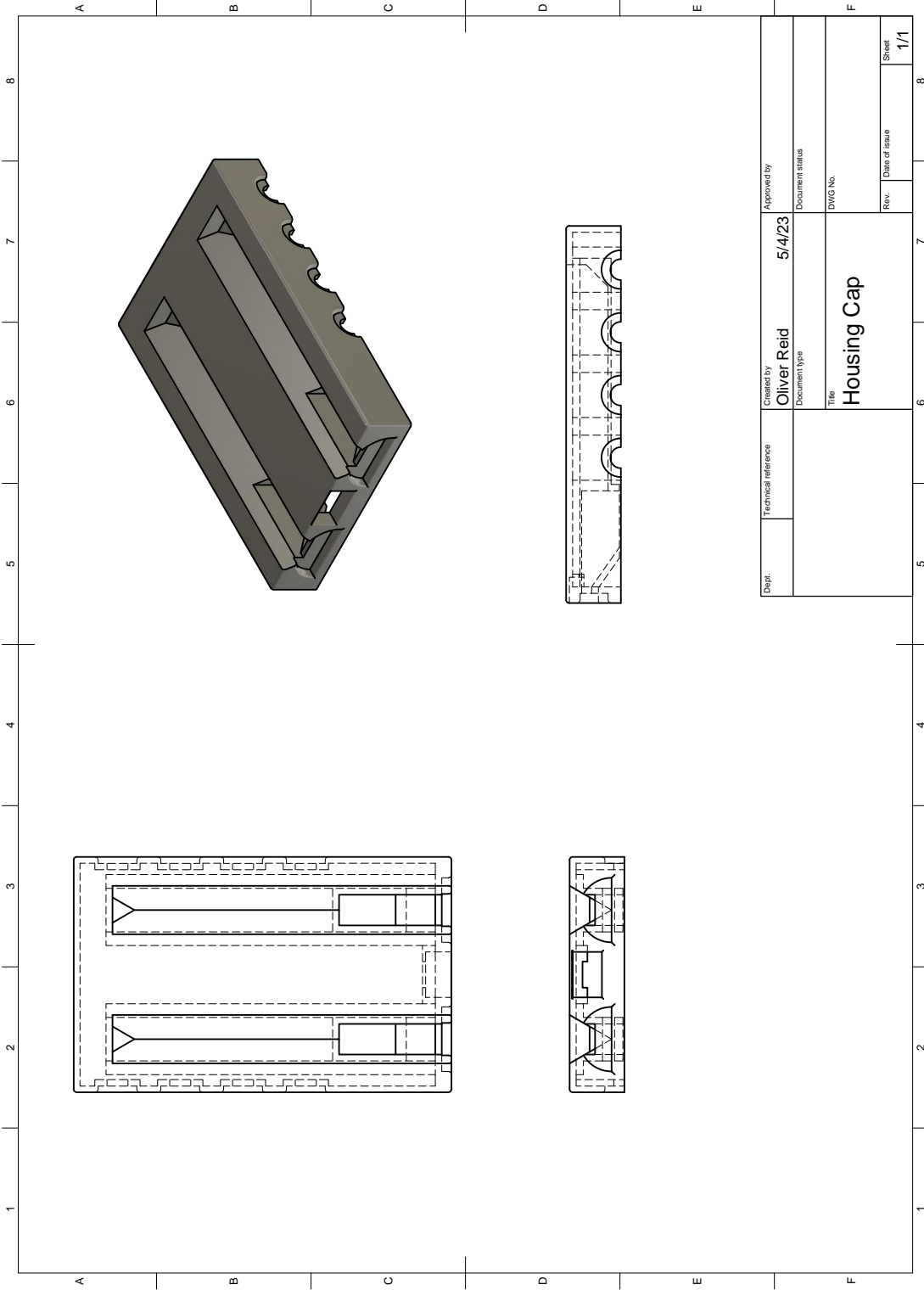

**Figure 13B** Side view of final housing with chip design integrated

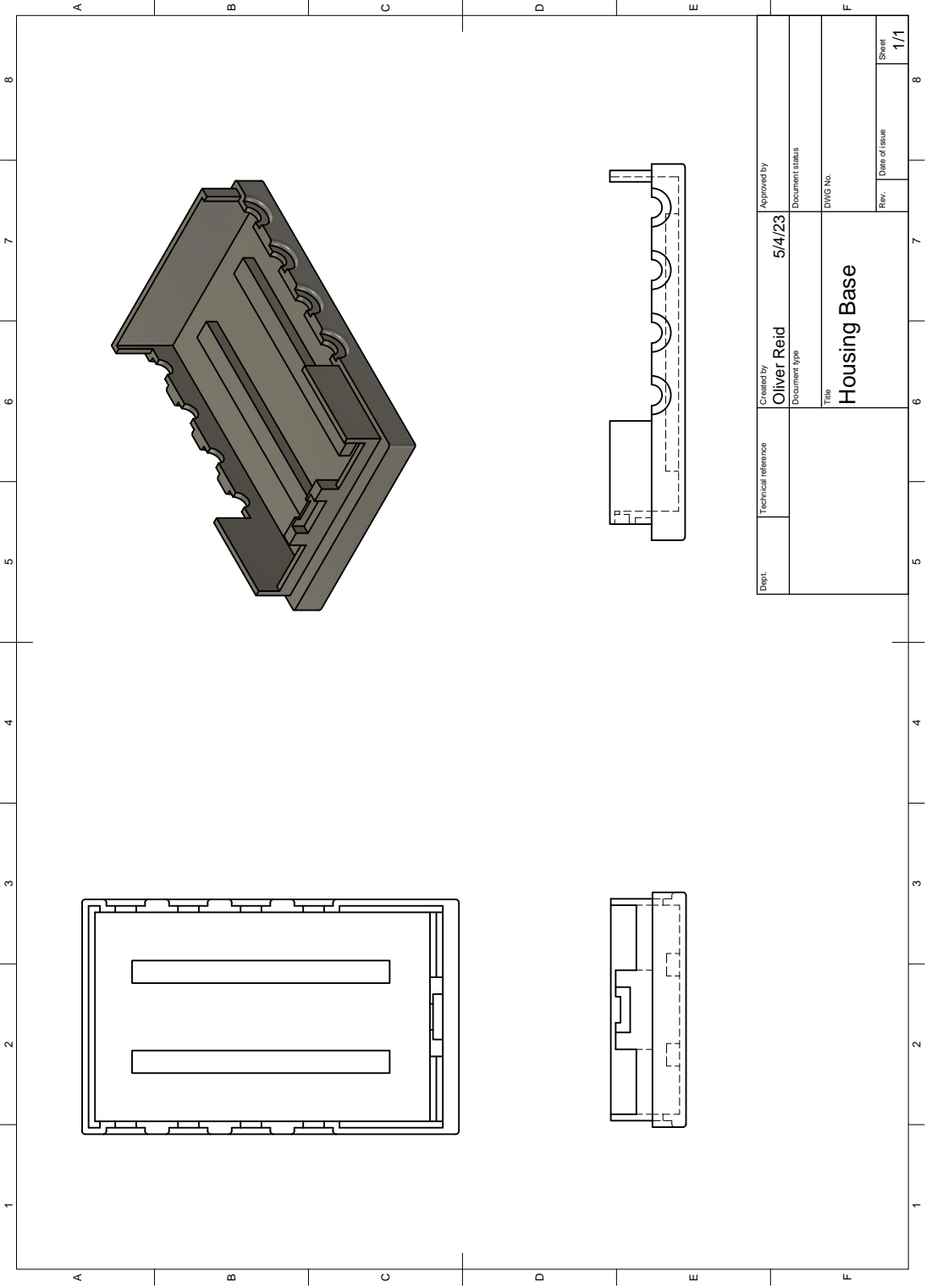

**Figure 13C** Isometric view of final housing with chip design integrated





Dept.	Technical reference	Created by <b>Oliver Reid</b>	Approved by <b>5/4/23</b>
		Document type	Document status
		Title <b>Housing Cap</b>	DWG No.
		Rev.	Date of issue
			Sheet <b>1/1</b>



Dept.	Technical reference	Created by <b>Oliver Reid</b>	Approved by	5/4/23	Document status
		Document type			
		Title	Dwg No.		
		<b>Housing Base</b>			
		Rev.	Date of issue	Sheet	1/1

Utilizing the feedback and experience of Dr. Hawkins-Chernof and Chris Helmick, a housing that allows for easy interchanging of PCB functions was completed. The housing securely holds the PCB while providing access to all its ports, and the chip design allows for simple insertion and removal. To simplify the process and remove any need for additional materials, a permanent marker was used to write the functionality of each chip and its respective switch functions.

## CONCLUSION

The goal at the beginning of the semester was to design a housing for the PCB that would protect it while also allowing easy interchangeability of the jumper functions and allowing access to all the PCB ports. The final design nicely meets those criteria and advice on how to further develop the project to help a broader group was given by Chris Helmick. This project is intended to grant more affordable and easy access to gaming communities for individuals with disabilities, but the applications of the device are not limited to just gaming. Using computers has become a normal and necessary way to interact with our society and access information. A disability shouldn't limit your ability to access the internet or use a computer. This device offers so much flexibility between its 15 fully customizable function sets and easy interchangeability between them. A [video submission](#) of this device was entered into the 2023 Make:able challenge in hopes that it will reach a broader group. It is one thing to design a product intended to make people's lives easier, but it is another thing to ensure the people who need it most can access it. This challenge will hopefully give the computer interface device exposure to experts that can recommend it, improve it, and bring it where it needs to go to actually start helping people.