

Washington University in St. Louis

Washington University Open Scholarship

Mechanical Engineering Design Project Class

Mechanical Engineering & Materials Science

Fall 2021

MEMS 411: Q.T. B-BAR, Gambian Pouched Rat Trap

Benjamin W. Horine Jr.
Washington University in St. Louis

Ileane Ho
Washington University in St. Louis

Sarangi Pathirana
Washington University in St. Louis

Follow this and additional works at: <https://openscholarship.wustl.edu/mems411>



Part of the [Mechanical Engineering Commons](#)

Recommended Citation

Horine, Benjamin W. Jr.; Ho, Ileane; and Pathirana, Sarangi, "MEMS 411: Q.T. B-BAR, Gambian Pouched Rat Trap" (2021). *Mechanical Engineering Design Project Class*. 177.
<https://openscholarship.wustl.edu/mems411/177>

This Final Report is brought to you for free and open access by the Mechanical Engineering & Materials Science at Washington University Open Scholarship. It has been accepted for inclusion in Mechanical Engineering Design Project Class by an authorized administrator of Washington University Open Scholarship. For more information, please contact digital@wumail.wustl.edu.



Washington University in St. Louis

JAMES MCKELVEY SCHOOL OF ENGINEERING

FL21 MEMS 411 Mechanical Engineering Design Project

Q.T. B-BAR

GAMBIAN POUCHED RAT TRAP

Gambian pouched rats have been used to aid the mine clearing efforts in East Africa since 2013.

They are capable of detecting the chemical compounds found in explosives and alert civilians about its location all without activating the landmines. These rodents are in high demand, but can only be found in forests, mounds, and other natural environments in Africa. To capture them in their natural habitat, a safe and effective live trap must be built, especially since commercial traps have harmed or injured the rodents in the past. The main design requirements for the trap are as follows: exterior must be smooth for easy deployment in natural environments, interior must also be smooth to ensure the rodent's safety, all parts must be mechanical as electrical components may fail in the field, and overall design must be simple, cost-effective, and lightweight. The engineering design process was implemented to meet these customer needs as effectively as possible. Chronologically, this included problem-understanding, initial concept generation, concept selection, concept embodiment, design refinement, and final prototype. In the problem-understanding phase, an interview was conducted with Dr. Stanton Braude to understand what he needed the live trap to do and under what constraints. From this interview, three separate designs were created in the concept generation stage, along with a general morphological chart. To select the working design, an Analytical Hierarchy Process (AHP) was used and engineering models were explained for the chosen design. Following this stage, CAD models were created to visualize the chosen design, as well as physical proofs-of-concept to test working mechanisms. A design refinement process allowed for an improved and redesigned working concept. Lastly, a final prototype and provided to the client.

HO, Ileana
HORINE, Benjamin
PATHIRANA, Sara

Contents

List of Figures	2
List of Tables	3
Introduction	4
Problem Understanding	4
Existing Devices	4
Existing Device #1: Mouse Trap Bucket - Flip Slide Bucket Lid Mouse/Rat Trap .	4
Existing Device #2: Dr. Braude’s Rat Trap	5
Existing Device #3: Gingbau Live Chipmunk Trap Humane Rat Mouse Cage Trap	6
Patents	7
Cage Trap with Easy Set and Release Mechanism – US Patent #9060505	7
Tomahawk Cage Trap – US Patent #5862624	8
Codes & Standards	9
Material Used - Polyvinyl Chloride Pipe and Fittings – (ISO 4439: 1979)	9
3D Printed Material - MakerBot PLA Safety Data Sheet – (MB-002_US)	9
User Needs	9
Customer Interview	9
Interpreted User Needs	10
Design Metrics	10
Project Management	11
Concept Generation	12
Mockup Prototype	12
Functional Decomposition	13
Morphological Chart	14
Alternative Design Concepts	15
Zeus Blue vZero	15
The Gambian’s Gamble	16
Poseidon Vantablack 3.0	17
Concept Selection	18
Selection Criteria	18
Concept Evaluation	18
Evaluation Results	19
Engineering Models/Relationships	19
Hooke’s Law	19
Force on Gear	20
Testing for Torsional, Bending and Shear Load	21
Concept Embodiment	22
Initial Embodiment	22
Proofs-of-Concept	26
Design Changes	27

Design Refinement	28
Model-Based Design Decisions	28
Work done by Rat	28
Bending of PVC Pipe	28
Spring Stiffness to Raise Flag	28
Design for Safety	29
Risk #1: The thickness of a standard 6 inch PVC pipe	30
Risk #2: Spring holding the flag stick down used as a signal	30
Risk #3: The trap door attachment to the tube breaking away from the tube	30
Risk #4: The tube breaking/deforming	30
Risk #5: External moving parts on the trap	30
Design for Manufacturing	31
Design for Usability	32
Vision Impairment	32
Hearing Impairment	32
Physical Impairment	32
Control Impairment	32
Final Prototype	32
Overview and Final Render	32
Documentation	33
Assembled Model	38
Bibliography	39
Appendix A Parts List	40
Appendix B Build Instructions	41
How To Assemble the Trap:	41
How To Engage the Trap:	42
How To Reapply Bait to the Trap:	42
List of Figures	
1 Image of Mouse Trap Bucket - Flip Slide Bucket Lid Trap [2]	4
2 Dr. Braude with his rat trap (Source: Captured Sep 10, 2021 with permission)	5
3 Image of the Gingbau Live Trap [3]	6
4 Patent images for Cage Trap with Easy Set and Release Mechanism [4].	7
5 Patent images for Tomahawk Cage Trap [5].	8
6 Gantt chart for design project	11
7 The front view of the trap	12
8 The trap with the door open	12
9 Showing one end of the trap with the removable lid on the back	12
10 Front view of the trap	12
11 Trap with the lid closed	12

12	Trap with the lid open showing the trigger induced pressure pad to close the door to prevent the rat from escaping	12
13	Function Tree for Giant Rat Trap, coded with tikz using <i>forest</i>	13
14	Morphological Chart for Giant Pouched Rat Trap.	14
15	Zeus Blue vZero	15
16	Concept Drawing for The Gambian's Gamble	16
17	Poseidon Vantablack 3.0	17
18	Analytic Hierarchy Process (AHP) to determine scoring matrix weights	18
19	Weighted Scoring Matrix (WSM) for choosing between alternative concepts	18
20	Schematic shows force diagram of spring and pressure plate system.	19
21	Schematic shows worm drive system	20
22	Schematic shows how the models will be tested for shear bending and torsional	21
23	Live hinged door when closed	26
24	Live hinged door when opened	26
25	Isometric view of engaged push paddle viewed (with end cap removed)	26
26	Push paddle extensions viewed from outside of trap	26
27	Rotary-pulley device attached to exterior of trap	27
28	Heat Map of different risks identified in the rat trap	29
29	Rendered photo of the Q.T. B-BAR Rat Trap at a closed state in the environment	33
30	Rendered photo of the Q.T. B-BAR Rat Trap with a clear body at a closed state in the environment	34
31	Side view of the Q.T. B-BAR Rat Trap in an opened state. Note how the Dowel Pin is in the door release and the Push Plate is fully extended	34
32	Side view of the Q.T. B-Bar Rat Trap in a closed state. Note how the Push Plate is compressed and Dowel Pin has been removed from the door release.	34
33	Q.T. B-BAR Rat Trap in a closed and released state	38
34	Q.T. B-BAR Rat Trap in a opened and engaged state	38

List of Tables

1	Interpreted Customer Needs for the Pouched Rat Trap (PRT)	10
2	Target Specifications	10
A.1	Parts list for the Q.T. B-BAR Rap Trap	40

Introduction

Dr. Stanton Braude’s research aims to further the demining efforts in East Africa using Gambian pouched rats. These rodents are capable of detecting the chemical compounds within buried explosives. With the proper training, they are also able to alert their handlers of the landmine location without detonating them. However, only young pouched rats can be effectively trained and tamed to do so. Therefore, Dr. Braude needs to capture adult pouched rats, breed them, and have their young be domesticated and trained. To achieve this, a safe and reliable live trap is needed. Specifically, the rat trap needs to be all mechanical, large enough to capture larger male and pregnant females pouched rats, cost effective for production, have a smooth interior to prevent harming the rodents, and a smooth exterior to ensure ease of placement in urban environments. Commercial rat traps have been tested and proved not suitable for Dr. Braude’s purposes. The Q.T. B-BAR trap aims to take all customer needs into consideration for every stage of the design process.

Problem Understanding

Existing Devices

The spring loaded mouse trap was the first mechanical pest control device invented in the late 1800s by Hiram Maxim [1]. This and many variants of mouse traps effectively kill the pest as it reaches towards the bait. Live traps for small animals were later invented in an effort to either humanely control their population or use the captured animal for other purposes. It is crucial to our project that the rats are alive and uninjured after they are captured. The live trap examples below were used for inspiration and guidance in our design process.

Existing Device #1: Mouse Trap Bucket - Flip Slide Bucket Lid Mouse/Rat Trap

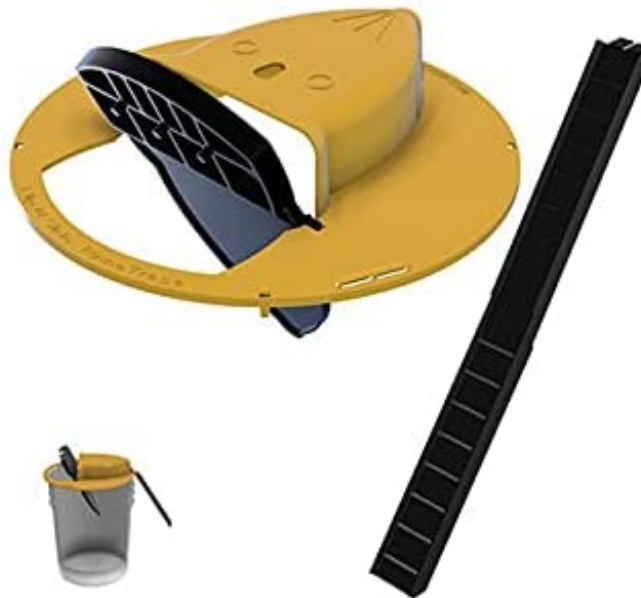

Figure 1: Image of Mouse Trap Bucket - Flip Slide Bucket Lid Trap [2]

Description: The Mouse Trap Bucket is a design that will use any existing 5 gallon bucket. This mouse trap works by using a ladder that will allow mice and other rodents to climb to the top of the bucket. At the top, there is a balanced platform that will tip over if they stand on it. This platform will drop the animals into the bucket and reset. This design is useful when you need to catch many small rodents.

Existing Device #2: Dr. Braude's Rat Trap

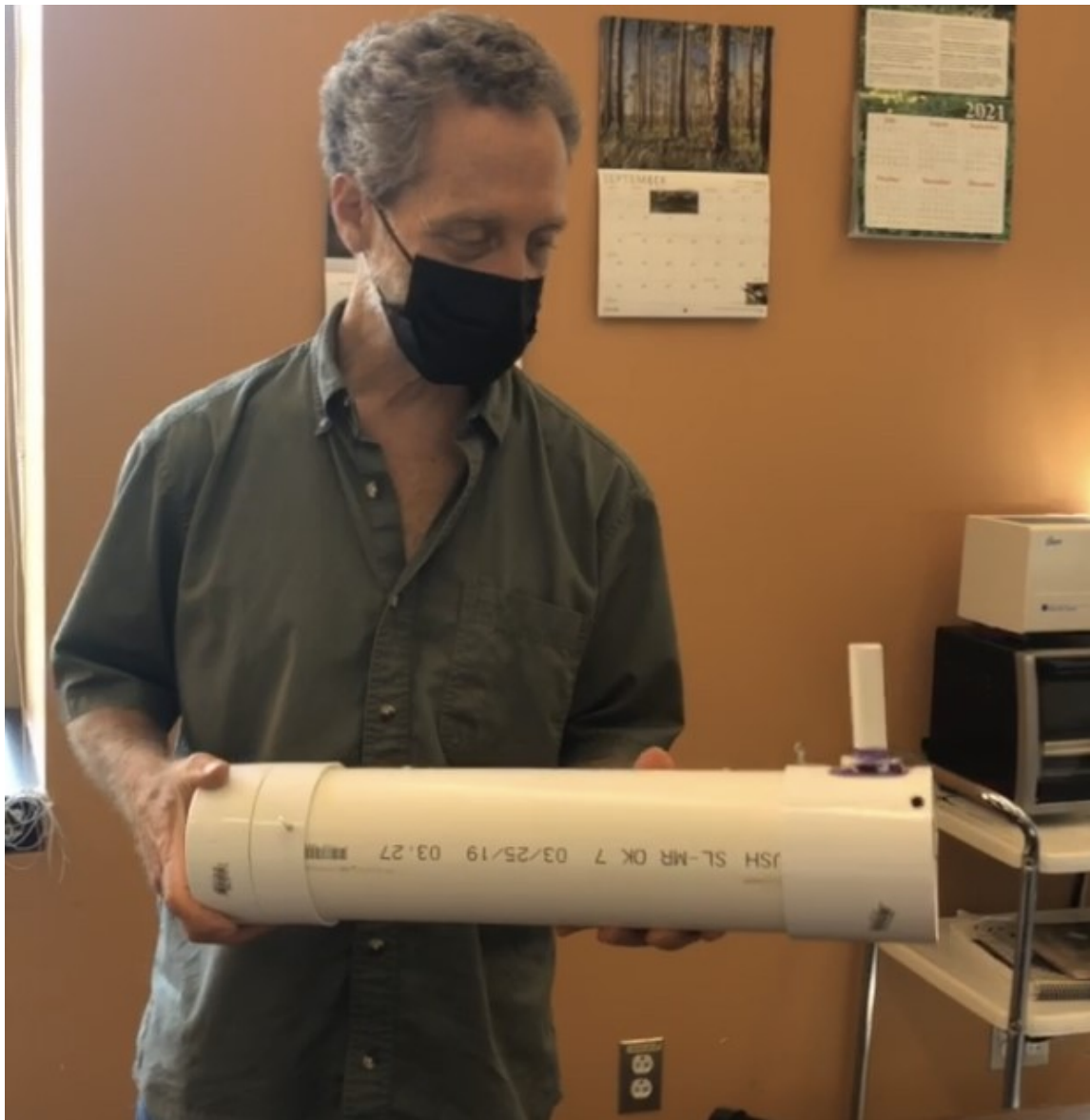

Figure 2: Dr. Braude with his rat trap (Source: Captured Sep 10, 2021 with permission)

Description: Dr. Braude's rat trap consists of a PVC pipe with a circular hinged door at one end, and a trigger pad and bait section at the other. The trigger is made of a steel wire that runs from the hinged door through the interior of the pipe and a 90 degree bent hexagonal shape that rests behind the trigger pad. When the rat pushes against the pad to get to the bait, the hexagonal wire is also pushed back, releasing the hinged door, and trapping the rat inside. Both ends of the trap

are removable and are attached to the pipe using thumb screws. The steel wire is also removable and is held in place solely by the tension against the opened door. The external locking mechanism is glued at the top, but has been described by Dr. Braude as “unnecessary and messed up”.

Existing Device #3: Gingbau Live Chipmunk Trap Humane Rat Mouse Cage Trap



Figure 3: Image of the Gingbau Live Trap [3]

Description: The Gingbau Live Trap is a way to catch one rodent by using a trip plate to engage a mechanically actuated door. The trip plate is located at the opposite end to ensure that the animal is inside the trap when the door closes. This trap is ideal because it allows the user to transport and release the animals that are caught. This is made from galvanized steel mesh to be lightweight and durable.

Patents

Cage Trap with Easy Set and Release Mechanism – US Patent #9060505

This patent uses a known cage trap method to enclose the animal in a vacant interior. The release mechanism is held between two positions, hold and release. The two positions allow for easy setup or easy release of captured animal. The animal will “trip” a plate which actuates an external mechanism which forces the door to be shut. This process is completely spring actuated and involves no external components.



<p>(12) United States Patent Rich et al.</p> <p>(54) CAGE TRAP WITH EASY SET AND RELEASE MECHANISM</p> <p>(75) Inventors: Christopher T Rich, Leola, PA (US); Robert T. Cruz, Wrightsville, PA (US); Edward J. Holliday, Lititz, PA (US); Marko Lubic, Shillington, PA (US)</p> <p>(73) Assignee: WOODSTREAM CORPORATION, Lititz, PA (US)</p> <p>(*) Notice: Subject to any disclaimer, the term of this patent is extended or adjusted under 35 U.S.C. 154(b) by 345 days. This patent is subject to a terminal disclaimer.</p> <p>(21) Appl. No.: 13/558,075</p> <p>(22) Filed: Jul. 25, 2012</p> <p>(65) Prior Publication Data US 2013/0047493 A1 Feb. 28, 2013</p> <p>Related U.S. Application Data</p> <p>(63) Continuation of application No. 12/149,758, filed on May 7, 2008, now Pat. No. 8,230,641, which is a continuation-in-part of application No. 11/097,195, filed on Apr. 4, 2005, now Pat. No. 7,370,451, application No. 13/558,075, which is a continuation-in-part of application No. 11/600,085, filed on Nov. 16, 2006, now Pat. No. 7,757,427.</p> <p>(51) Int. Cl. A01M 23/00 (2006.01) A01M 23/18 (2006.01)</p>	<p>(10) Patent No.: US 9,060,505 B2</p> <p>(45) Date of Patent: *Jun. 23, 2015</p> <p>(52) U.S. CL CPC A01M 23/18 (2013.01)</p> <p>(58) Field of Classification Search USPC 43/61, 60, 58 See application file for complete search history.</p> <p>(56) References Cited U.S. PATENT DOCUMENTS</p> <table border="0"> <tr><td>2,562,809 A *</td><td>7/1951</td><td>Mogren</td><td>43/61</td></tr> <tr><td>4,682,440 A *</td><td>7/1987</td><td>Hunter</td><td>43/61</td></tr> <tr><td>4,706,406 A *</td><td>11/1987</td><td>Mowatt et al.</td><td>43/61</td></tr> <tr><td>4,912,872 A *</td><td>4/1990</td><td>Wynn et al.</td><td>43/61</td></tr> <tr><td>5,862,624 A *</td><td>1/1999</td><td>Askins</td><td>43/61</td></tr> <tr><td>6,618,982 B2 *</td><td>9/2003</td><td>Lafforthun</td><td>43/61</td></tr> <tr><td>7,370,451 B2 *</td><td>5/2008</td><td>Rich et al.</td><td>43/61</td></tr> <tr><td>8,230,641 B2 *</td><td>7/2012</td><td>Rich et al.</td><td>43/61</td></tr> <tr><td>8,627,595 B2 *</td><td>1/2014</td><td>Radesky et al.</td><td>43/61</td></tr> <tr><td>8,782,946 B2 *</td><td>7/2014</td><td>Bocher</td><td>43/61</td></tr> <tr><td>2013/0047493 A1 *</td><td>2/2013</td><td>Rich et al.</td><td>43/61</td></tr> </table> <p>* cited by examiner</p> <p><i>Primary Examiner</i> — Christopher P Ellis (74) <i>Attorney, Agent, or Firm</i> — Jacobson Holman, PLLC.</p> <p>(57) ABSTRACT A cage type animal trap having an enclosure with an animal access opening into a vacant interior sized to receive an animal to be trapped. The access opening is closed by a door that is movable from a closed to an opened position by an actuating mechanism releasably held by a latch mechanism. The latch mechanism is configured to move between hold and release positions, the hold position moving the door to the opened position and the release position releasing the actuating member to allow the door to close and trap the animal in the animal enclosure.</p> <p>20 Claims, 24 Drawing Sheets</p>	2,562,809 A *	7/1951	Mogren	43/61	4,682,440 A *	7/1987	Hunter	43/61	4,706,406 A *	11/1987	Mowatt et al.	43/61	4,912,872 A *	4/1990	Wynn et al.	43/61	5,862,624 A *	1/1999	Askins	43/61	6,618,982 B2 *	9/2003	Lafforthun	43/61	7,370,451 B2 *	5/2008	Rich et al.	43/61	8,230,641 B2 *	7/2012	Rich et al.	43/61	8,627,595 B2 *	1/2014	Radesky et al.	43/61	8,782,946 B2 *	7/2014	Bocher	43/61	2013/0047493 A1 *	2/2013	Rich et al.	43/61
2,562,809 A *	7/1951	Mogren	43/61																																										
4,682,440 A *	7/1987	Hunter	43/61																																										
4,706,406 A *	11/1987	Mowatt et al.	43/61																																										
4,912,872 A *	4/1990	Wynn et al.	43/61																																										
5,862,624 A *	1/1999	Askins	43/61																																										
6,618,982 B2 *	9/2003	Lafforthun	43/61																																										
7,370,451 B2 *	5/2008	Rich et al.	43/61																																										
8,230,641 B2 *	7/2012	Rich et al.	43/61																																										
8,627,595 B2 *	1/2014	Radesky et al.	43/61																																										
8,782,946 B2 *	7/2014	Bocher	43/61																																										
2013/0047493 A1 *	2/2013	Rich et al.	43/61																																										

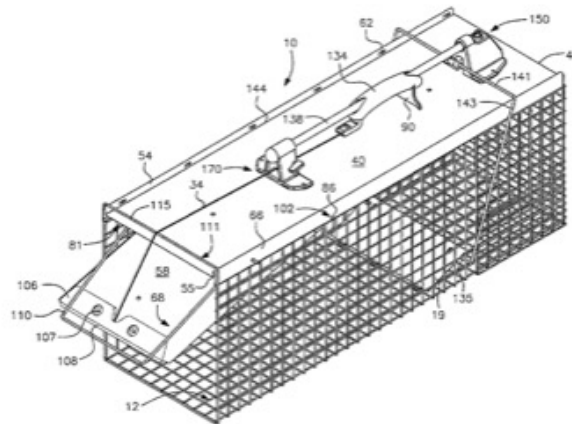



Figure 4: Patent images for Cage Trap with Easy Set and Release Mechanism [4].

Tomahawk Cage Trap – US Patent #5862624

This patent is a staple design that uses a mesh cage that can fold when you need to travel or store it. The front door has an actuated mechanism that is tripped when an animal enters the vacant space. The door will spring closed shut. Every functioning mechanism aside from the trip plate is external there fore the animal will not be able release the mechanism from the inside.



US005862624A

United States Patent [19] [11] **Patent Number:** **5,862,624**
Askins [45] **Date of Patent:** **Jan. 26, 1999**

[54] **CAGE TRAPS** 5,329,723 7/1994 Lial _____ 43/61
 5,549,073 8/1996 Askins et al. _____ 119/474

[75] Inventor: **William E. Askins, Litz, Pa.**

[73] Assignee: **Woodstream Corporation, Litz, Pa.** 593752 2/1934 Germany .

[21] Appl. No.: **600,160**

[22] Filed: **Feb. 12, 1996**

[51] Int. Cl.⁵ _____ **A01M 23/18**

[52] U.S. Cl. _____ **43/61; 43/58; 43/60**

[58] Field of Search _____ **43/58, 60, 61, 43/62, 70; 119/474**

FOREIGN PATENT DOCUMENTS

OTHER PUBLICATIONS

Tomahawk Live Trap Company Brochure; pp. 1-8 (1994).
 Havahart Brochure from Woodstream; pp. 1-8 (1994).

Primary Examiner—Michael J. Carone
Assistant Examiner—Darren Ark
Attorney, Agent, or Firm—Jacobson, Price, Holman & Stern, PLLC

[56] **References Cited**

U.S. PATENT DOCUMENTS

1,054,564	2/1913	Kline .	
1,327,229	1/1920	Erickson .	
1,410,738	3/1922	Dorseth .	
1,453,795	5/1923	Hovell .	
2,167,291	7/1939	Bowman .	
2,692,453	10/1954	Wingfield .	
2,725,661	12/1955	Bowman .	
2,965,259	8/1960	Johnson .	
3,834,063	9/1974	Souza et al. _____	43/70
3,896,766	7/1975	Martin _____	119/474
3,913,258	10/1975	Souza et al. _____	43/60
3,975,857	8/1976	Beanson et al. _____	43/61
4,162,588	7/1979	Wyant _____	43/61
4,484,540	11/1984	Yamamoto .	
4,527,512	7/1985	Sugiara .	
4,546,568	10/1985	Seyler _____	43/62
4,557,067	12/1985	Ha .	
4,567,688	2/1986	McKee _____	43/61
4,604,823	8/1986	Ponzo .	
4,696,257	9/1987	Neary et al. .	
4,762,085	8/1988	Ondrasik _____	119/17
4,829,700	5/1989	Ha _____	43/61
5,010,848	4/1991	Rankin .	

[57] **ABSTRACT**

A cage-like animal trap has a door mechanism at a front end of the trap which closes on an animal inside of the trap when the animal steps on an internal trip pan while going for bait positioned at the rear of the trap. The door mechanism has a main body panel pivoted to the roof of the trap and a reactor plate pivotally connected to the bottom edge of the body panel and urged away from the body panel by a spring. In the open position, the body panel and reactor plate are squeezed together and lie flat against the roof of the trap held in place by a hook-like trigger in the roof. When the trigger is released by an animal stepping on the trip pan, the body panel of the door is lowered by gravity and the reactor plate springs away from the body panel with its top edge sliding outwardly along the inside of the roof until it engages a stop at the front of the roof. A drop latch in the roof prevents the top edge of the reactor plate from sliding back to the open position of the door mechanism unless the catch is lifted from outside of the trap so that the trapped animal cannot open the door from inside the trap. The trap is disclosed in collapsible and non-collapsible versions.

9 Claims, 7 Drawing Sheets

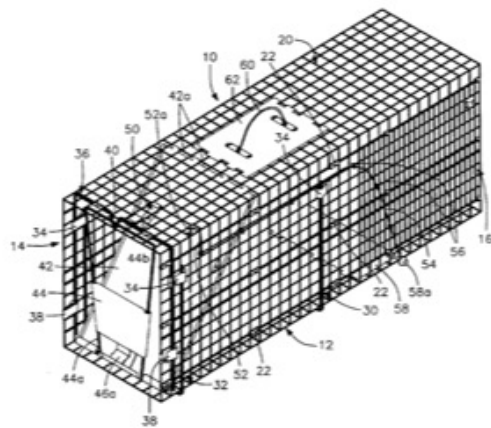

Figure 5: Patent images for Tomahawk Cage Trap [5].

Codes & Standards

Material Used - Polyvinyl Chloride Pipe and Fittings – (ISO 4439: 1979)

This International Organization for Standardization sets the standards for the permissible limits of density for unplasticized polyvinyl chloride for pipes and fittings. The standard is between 1.35 grams to 1.46 grams of PVC per cubic centimeters [6]. This standardization allows us to ensure that the material used is consistent and that there is repeatably in its function.

3D Printed Material - MakerBot PLA Safety Data Sheet – (MB-002_US)

This MakerBot Safety Data Sheet includes information relating to occupational safety and health hazards for the use of PLA 3D Printer Filament [7]. It is important that we both handle this product safely and ensure that it will not cause injury to the captured rats.

User Needs

The success of our product relies on meeting the needs of the user, Dr. Braude. The first interview and our interpretation of his requirements are captured below, and we will continue to communicate with Dr. Braude throughout the design and build process.

Customer Interview

Interviewee: Dr. Stanton Braude

Location: McDonell 306, Washington University in St. Louis, Danforth Campus

Date: September 10th, 2021

Setting: Dr. Braude brought his Giant Pouched Rat Trap that he is currently using in East Africa and showed us the features it currently possess. He also described all the features he would like to change to make it more effective in catching the rats. The interview was conducted in the Room 306 in the McDonell Building for the duration of 1 hour.

Interview Notes:

What is the purpose of the device?

- The trap is used to catch giant pouched rats alive and uninjured for a period of at least 12 hours.

What product do you currently use and what features work well for you?

- We currently use the rat trap that I designed (Device 2). Its lock mechanism and the overall trapping of the rat works well. It would be preferred that the same material, PVC, is used because it is strong, flexible, reliable and smooth. Also the trap needs to be 100% mechanical.

What are some design challenges that you have with the current product?

- Firstly, there is a wire that runs on the inside that when pushed on by the rat activates the locking mechanism and traps the rat in. However, these rats do not become passive when trapped and instead becomes more aggressive trying to find a way out. This struggle injures them. In addition, the latch system protruding on the outside of the trap makes it difficult to place them in vegetation and along the river beds. The rat trap also needs to be a few inches larger making the trap at least 5 inches in diameter to enable us to catch adult males and pregnant females. Ideally the pentagon wire is replaced with a plastic paddle to prevent injury to the rat.

What other features would you like to be improved on the new trap?

- Ideally the pentagon wire along the lock mechanism is replaced with a plastic paddle to prevent injury to the rat. It would be preferred that the lid that contains the bait on the end of the trap has a screw cap instead of just a cap on.

What do the rats eat? What do you use as bait?

- Fallen fruit and small insects for rats in the villages and the rats in the city are scavengers and find trash and lives in the sewers.

Interpreted User Needs

Below is a table of our interpretation of Dr. Braude’s requirements and their relative importance on a 1-5 scale. PRT stands for pouched rat trap.

Table 1: Interpreted Customer Needs for the Pouched Rat Trap (PRT)

Need No.	User Need	Importance
1	PRT is reliable	5
2	PRT is lightweight	4
3	PRT interior is smooth to prevent rat injury	5
4	PRT exterior is smooth to allow easy placement	4
5	PRT is only mechanical	5
6	PRT will not kill the rat	5
7	PRT will fit large male or pregnant female rats	4
8	PRT will be safe to transport on airplanes	4
9	PRT can be connected to carry multiple loaded traps at one time	2
10	PRT does not exceed \$20 USD	3
11	PRT is made from a material that is flexible and strong (ex. PVC)	4
12	PRT has a simple locking mechanism, prevents the rat from escaping	4

Design Metrics

Using the requirements mentioned, below is a table of how Dr. Braude’s needs are quantified with an ideal and acceptable limit.

Table 2: Target Specifications

Metric No.	Associated Needs	Metric	Units	Acceptable	Ideal
1	1, 12	Operation time before major repair	days	>365	>1095
2	2	Total weight	kg	<2	<1
3	7	Minimum diameter	m	>0.127	>0.154
4	3,4	Surface roughness	mm	<0.045	0.0015
6	10	Cost per unit	USD	<20	<15
7	11	Material stiffness	kPa	>317	>150

Project Management

The Gantt chart in Figure 6 gives an overview of the project schedule.

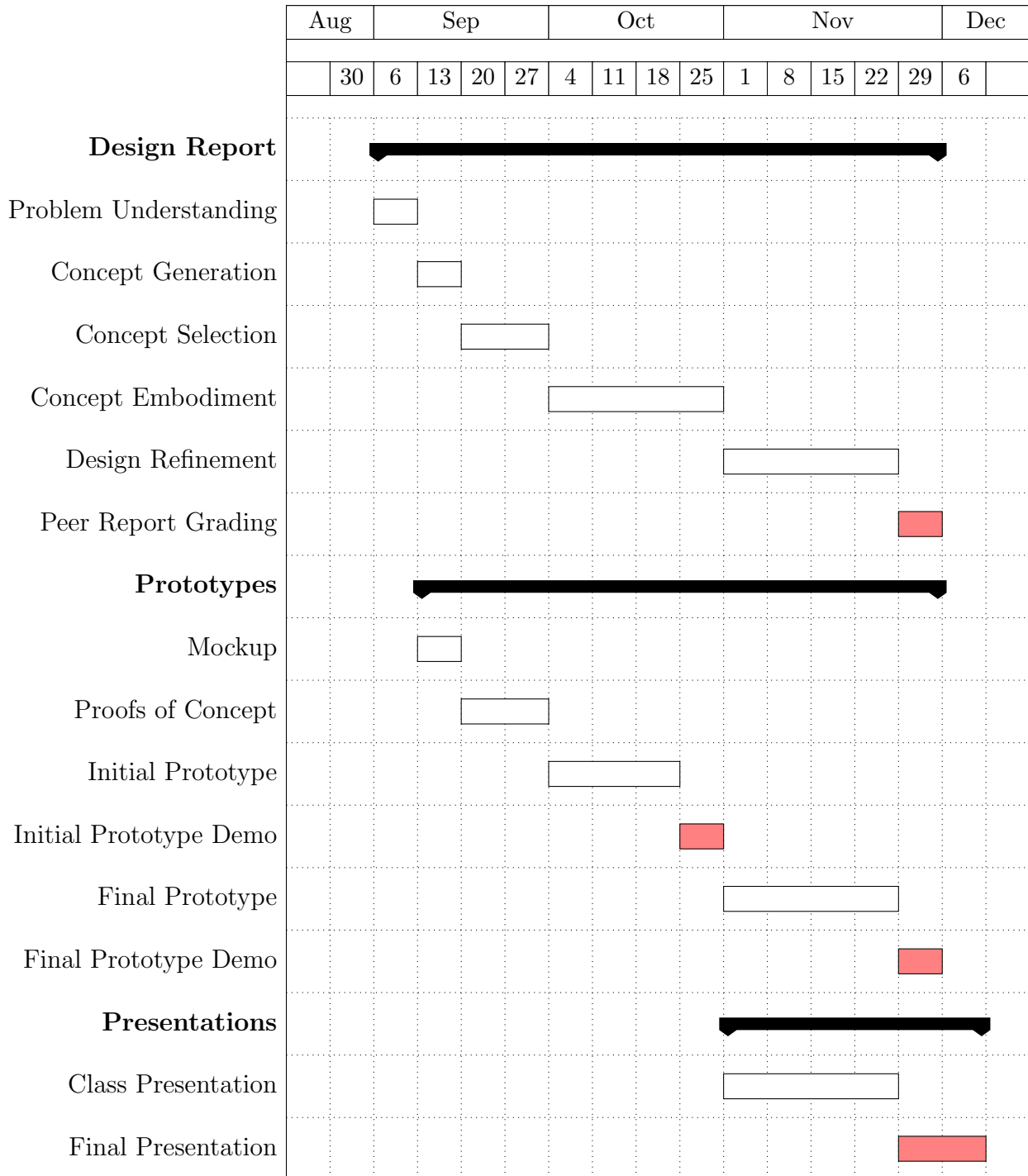

Figure 6: Gantt chart for design project

Concept Generation

Mockup Prototype

The figures below show the mock up prototype made from cardboard and painter's tape to demonstrate the main features of the rat trap that will be designed. The trap was 12"x12"x32".



Figure 7: The front view of the trap



Figure 8: The trap with the door open

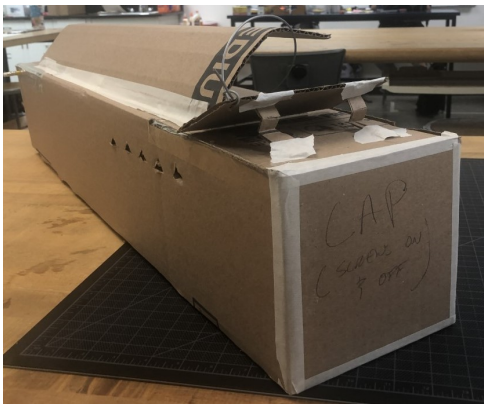

Figure 9: Showing one end of the trap with the removable lid on the back



Figure 10: Front view of the trap



Figure 11: Trap with the lid closed



Figure 12: Trap with the lid open showing the trigger-induced pressure pad to close the door to prevent the rat from escaping

Functional Decomposition

The function tree shows the primary and secondary functions in a mechanism. The primary function of the rat trap is to capture while the user is away. There are no safe and humane commercial traps available. The primary goal of this rat trap is to capture the rat alive and uninjured. The secondary functions that follow are aimed towards achieving that goal.

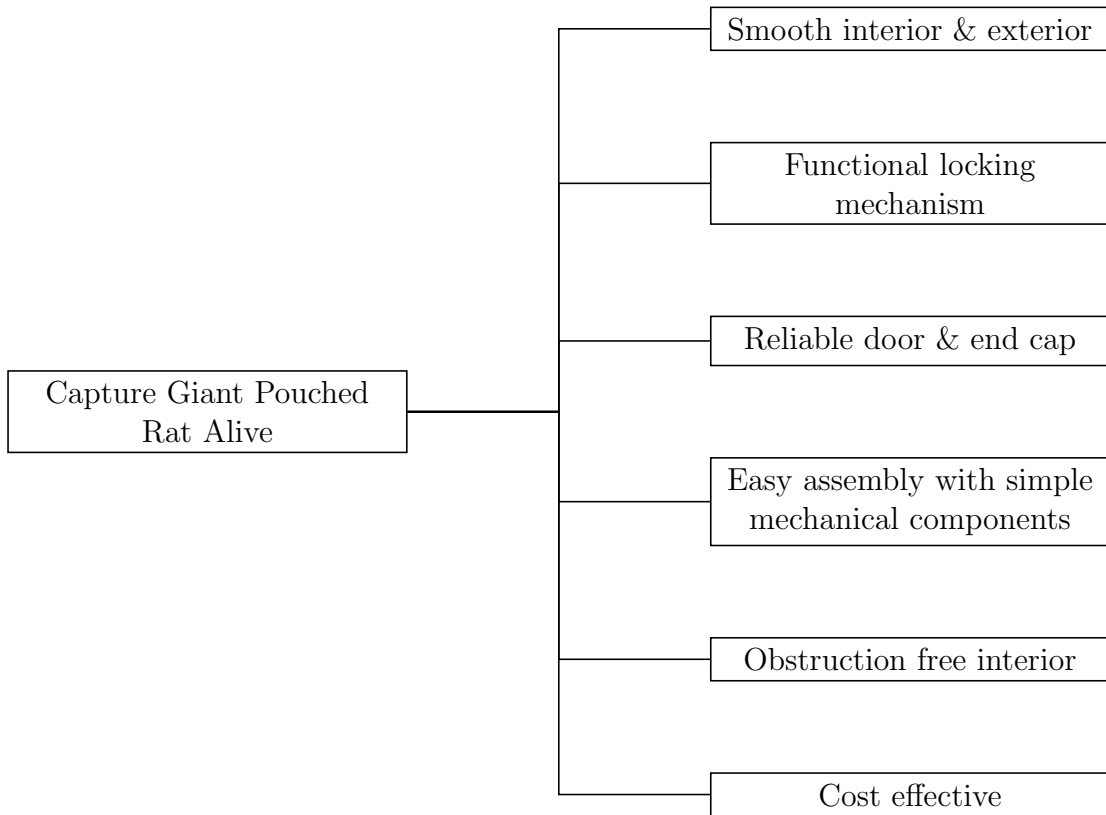

Figure 13: Function Tree for Giant Rat Trap, coded with tikz using *forest*

Morphological Chart

A morphological chart describing material, shapes, mechanisms, parts, assemblies, and supports. This helps in creating alternative concept designs.















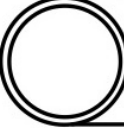
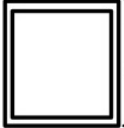



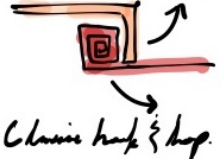

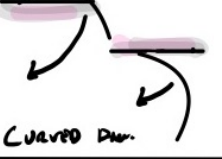

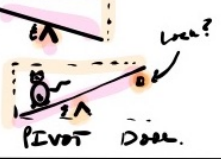



Topic Category	1	2	3	4
Material Type	 PVC	 3D PLA/PETG	 Aluminum	 Wood
Shape/Profile	 Circle Tube	 sq Tube	 Arch Top sq Bottom	 Gutter
Locking Mechanism	 Extrinsic Latch	 Wood Flap Latch	 Chain hook & loop	 STRAP MOUNTED
Door Mechanism	 OPEN CLOSE	 CURVED DOOR	 SLOTTED SLIDE	 PIVOT DOOR
End Cap	 EXT. SCREW	 SCREW	 Natural Wood	 SCREW
Assembly	 PRESS FIT	 SCREW	 BRACKET	 DOWEL PINS
Ventilation	 End Cap Hole	 AIR SLOTS	 Double Wall	 Mesh screen
Foundation Support	 NONE	 BLOCK SUPPORT	 Poured Concrete	 CLASP

Figure 14: Morphological Chart for Giant Pouched Rat Trap.

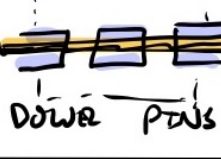
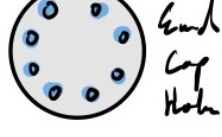
Alternative Design Concepts

Zeus Blue vZero

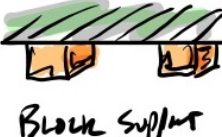
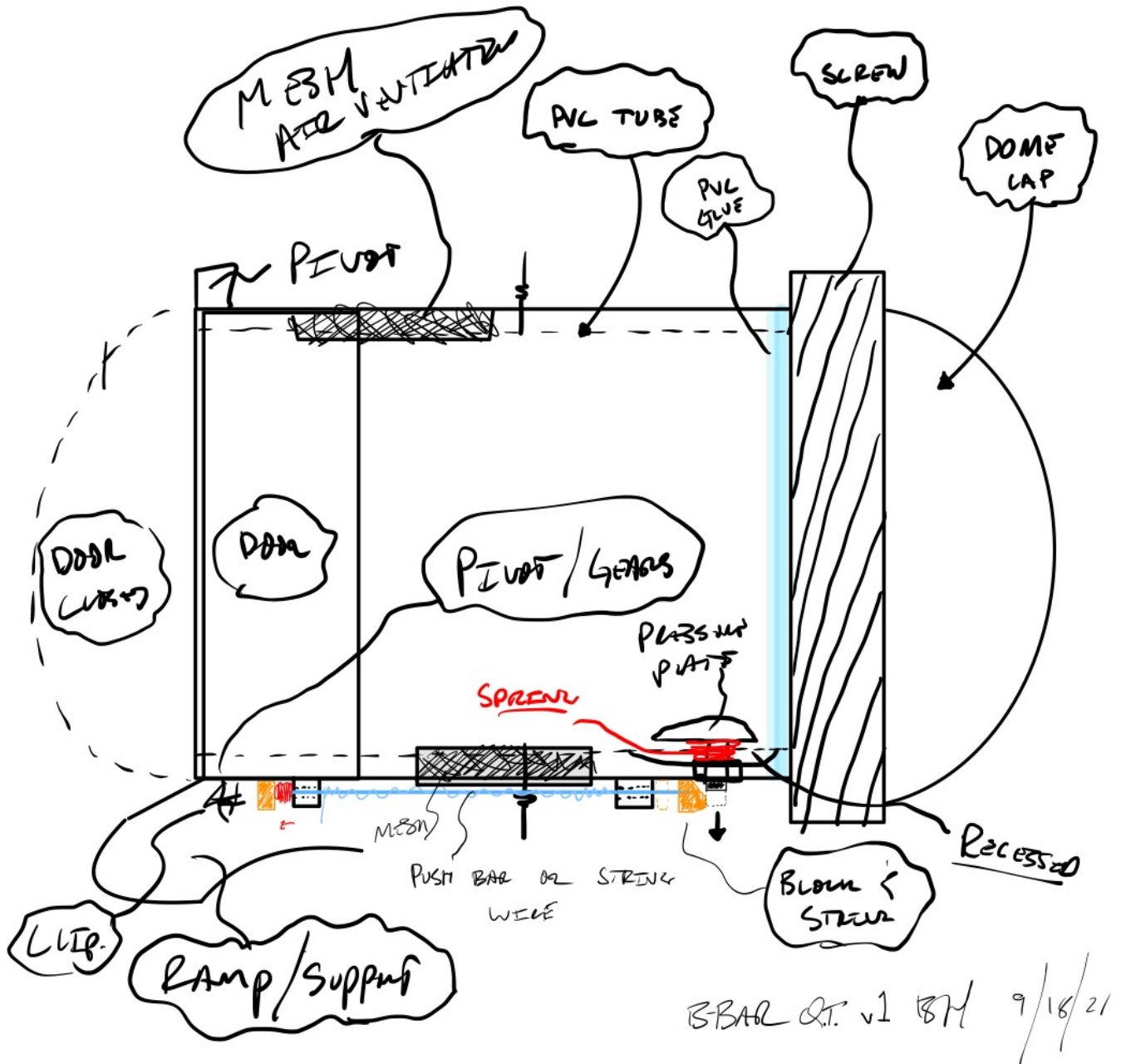

Figure 15: Zeus Blue vZero

Description: Zeus Blue incorporates all of the necessary features needed from the customer. This concept delivers new components to help reduce weight and be more reliable. The primary way to reduce weight is to use a spring and string actuated system to close the door. There is a small plate with a spring connected to a string and string plate. These are forced into tension when the door is open. When the pressure plate is depressed, the string will lose all its tension. This lack in tension will release a spring on the opposite side of the trap. This string will actuate the mechanism to close the doors. Additionally, there is an added option for customization. Additional

ventilation and drainage is incorporated through fine mesh screens to prevent injury to the rat. The floor supports feature generic cleats. Anything can be printed or made to fit these cleats. This means the customer can have a footplate for the trap resting on the ground, or they could have a stand/strap to suspend it in a marsh or sewer. Lastly, the stream less and sleek design of Zeus Blue will not only allow for more rat safety, but it will also satisfy one of the most important requests from the customer: “elegance”.

The Gambian’s Gamble

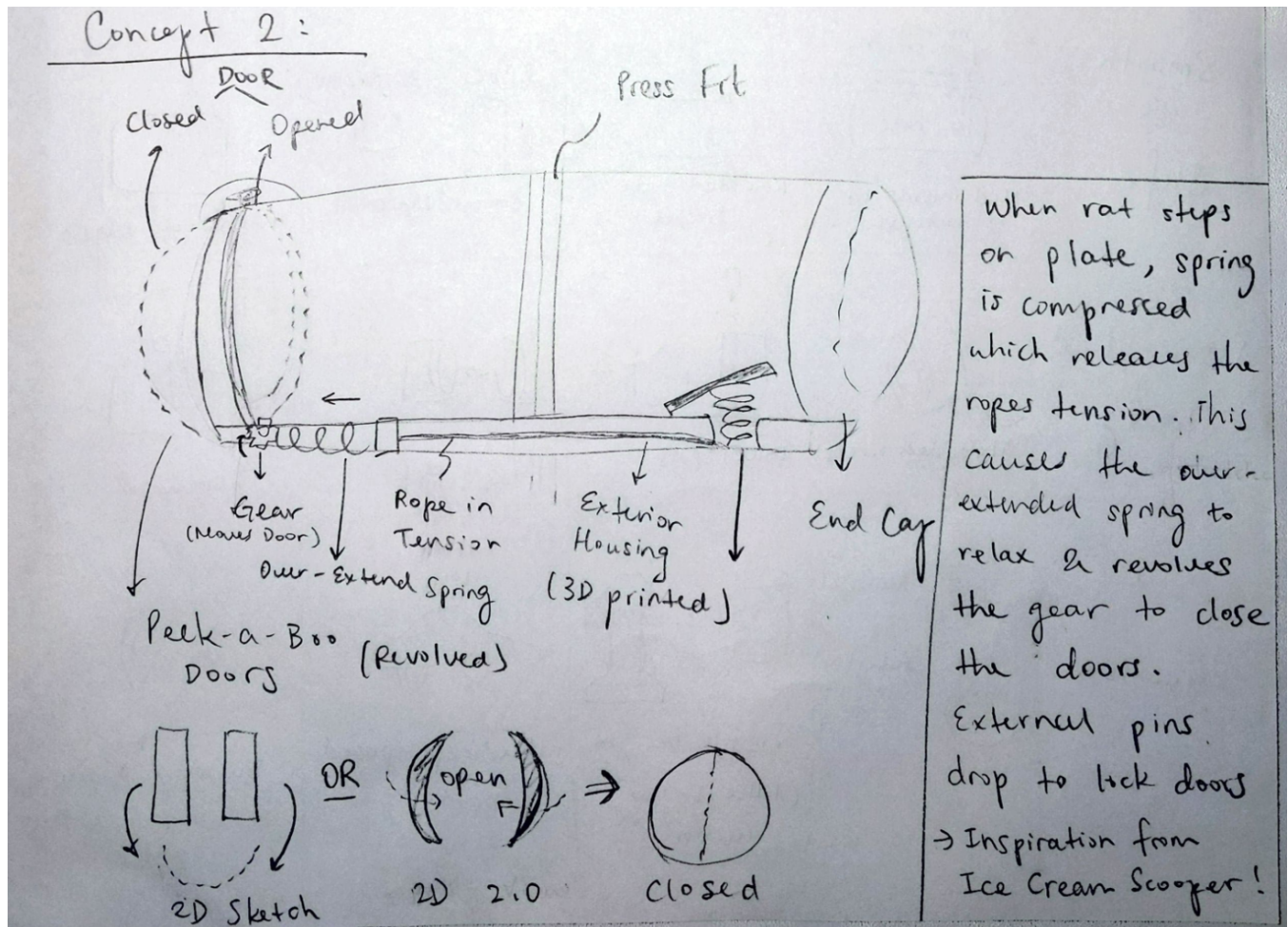

Figure 16: Concept Drawing for The Gambian’s Gamble

Description: The Gambian’s Gamble model has revolving doors that are flush against the interior of the pipe when opened and extrude out to a hemisphere when closed. The door is triggered to shut when the spring plate is compressed as the tension in the rope or rod will relax. This causes the gears to turn, revolving the door panels, and dropping the top pin to lock the door in place. These components will be housed outside of the main PVC body to ensure that the interior is smooth and safe for the rat to thrash around. The main body is press fit together to make assembly easy, and the end cap is threaded also. The selection of PVC material was deliberate as its lightweight, durable, and cost effective.

Poseidon Vantablack 3.0

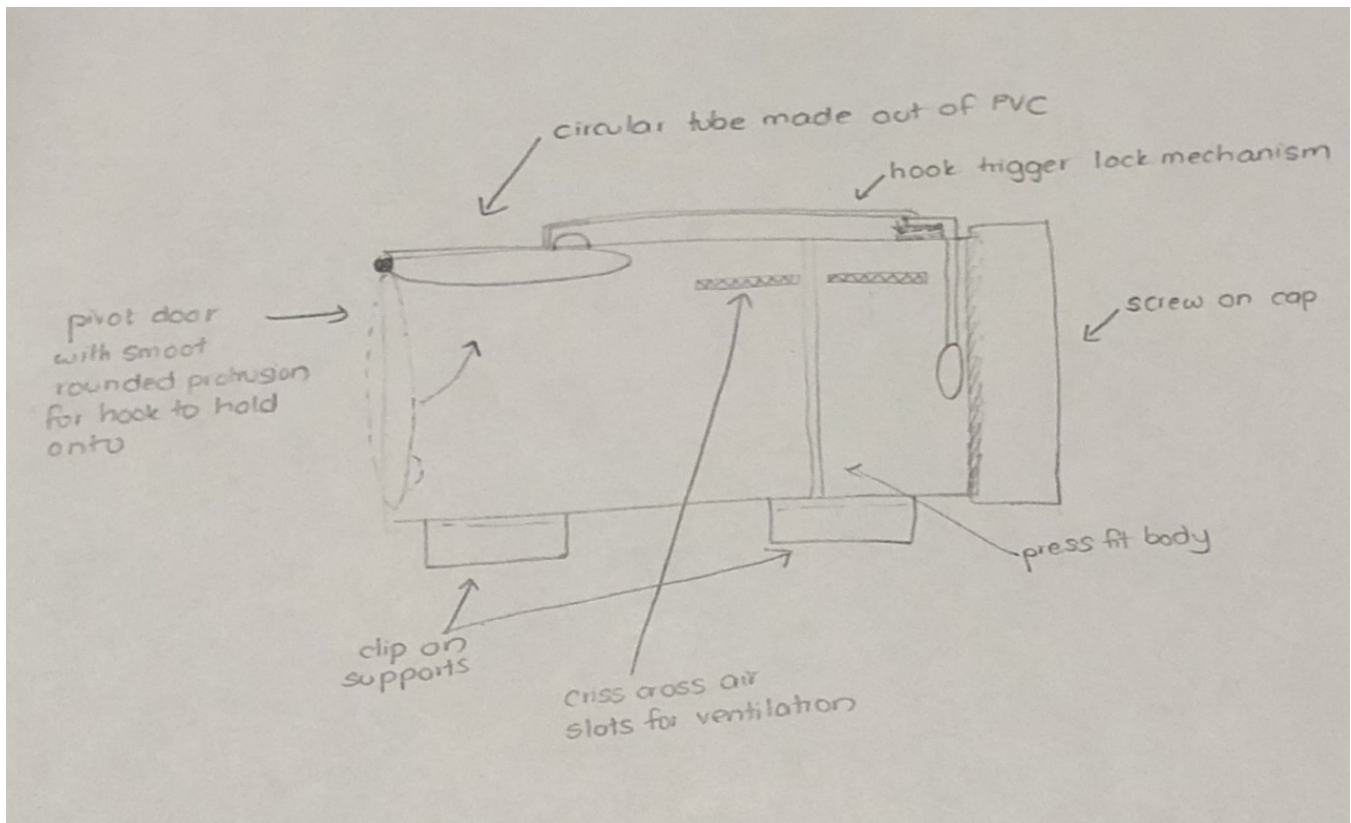

Figure 17: Poseidon Vantablack 3.0

Description: The Poseidon Vantablack 3.0 is circular for convenient and quick placement of the trap in vegetation or along river bed or in sewage pipes. It has clip on supports and to help place them in unique circumstances such as muddy river banks. It has criss cross air slots to help with ventilation and keep the rats alive until someone comes to collect the traps. The trap is made out of PVC because it is strong and durable yet quite flexible. This allows for easy transport without the fear of breaking a trap made out of PGA. Also allows the trap to be light weight. In addition, through previous experience of the client, the rats do not eat through or damage the PVC and also the smoothness helps prevent the rat from hurting itself. The door is pivot door with a small smooth semi circular protrusion at the end of the door. This protrusion acts as a stopper for hook to hang onto it. However when a rat enters the trap and pushes on the circular smooth plastic trigger on the inside, the latch falls allowing the door to close and trap the rat inside. The body of the trap is press fit. The end cap is a screw on for convenient and efficient placement of bait. Eventually a cover will be designed to hide the trigger on top of the tube to make the design sleeker.

Concept Selection

Selection Criteria

The Analytical Hierarchy Process (AHP) allows us to define the relative priority of each criteria which were chosen from the interpreted user needs. These weighted priorities then makes choosing a well-rounded concept easier and more objective.

	Ease of Assembly	Affordability	Reliable Mechanisms	Mechanical Safety	Aesthetic Appeal			
Ease of Assembly	1.00	0.20	0.14	0.11	0.33	Row Total	1.79	3.09
Affordability	5.00	1.00	0.20	0.20	3.00	Weight Value	9.40	16.25
Reliable Mechanisms	7.00	5.00	1.00	1.00	7.00	Weight (%)	21.00	36.29
Mechanical Safety	9.00	5.00	1.00	1.00	5.00		21.00	36.29
Aesthetic Appeal	3.00	0.33	0.14	0.20	1.00		4.68	8.08
Column Total:							57.86	100.00

Figure 18: Analytic Hierarchy Process (AHP) to determine scoring matrix weights

Concept Evaluation

A Weighted Score Matrix (WSM) is a matrix that compares certain criterion to multiple concepts. This matrix uses criterion and weights from the AHP. Each design is rated from 1 (Poor) to 5 (Best) on how it would perform in each criterion.

Alternative Design Concepts		Gambian Gamble		Zeus Blue vZero		Posiden Vantablack	
							
Selection Criterion	Weight (%)	Rating	Weighted	Rating	Weighted	Rating	Weighted
Ease of Assembly	3.09	3.00	0.09	3.00	0.09	4.00	0.12
Affordability	16.25	4.00	0.65	3.00	0.49	4.00	0.65
Reliable Mechanisms	36.29	3.00	1.09	4.00	1.45	4.00	1.45
Mechanical Safety	36.29	4.00	1.45	4.00	1.45	4.00	1.45
Aesthetic Appeal	8.08	4.00	0.32	4.00	0.32	3.00	0.24
Total score		3.606		3.807		3.919	
Rank		3		2		1	

Figure 19: Weighted Scoring Matrix (WSM) for choosing between alternative concepts

Evaluation Results

The Poseidon Vantablack 3.0 concept was the best ranked concept. This concept scored the most on ease of assembly compared to the other two as it was a much simpler design and thus easier and convenient to assemble. It also scored the highest on affordability as the cost of production is relatively low compared to the other two due to cheaper components and less complex design. It scored the highest on reliable mechanism due to the simplistic nature. The trap door is purely mechanical attached by a hinge and held up by a simple trigger set of by the rat. The other two designs have more complex door/trigger mechanism that could be affected during repeated use and mud and dirt getting in the hinges. Thus Poseidon Vantablack 3.0 was deemed to be more reliable and robust. This concept scored the least in the mechanical safety criteria and this is because this concept is very simple in its design and was meant to capture the rat and less about the safety. The other two concepts were designed with the safety of the rat in mind where they had no possibility of being injured after its capture as they struggle to find a way out. The aesthetic appeal is included in this matrix due to the customer request of an “elegant and respectable” rat trap. This is important because the past variations that the customer used have been unappealing and unprofessional.

Engineering Models/Relationships

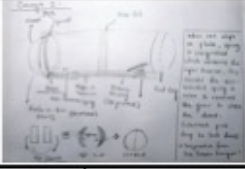
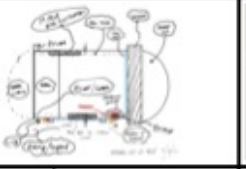
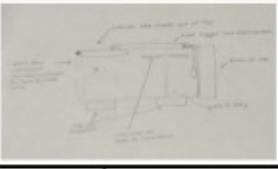
Hooke's Law

This project requires some sort of “actuating” device that the rat will interact with. The easiest way to implement that is through a pressure plate on top of a spring. This provides the necessary displacement needed to trip our locking mechanism. The plate will offer a necessary surface area that will protect the spring mechanism from the rat, and the rat from the spring mechanism. The engineering model needed here is Hooke's Law:

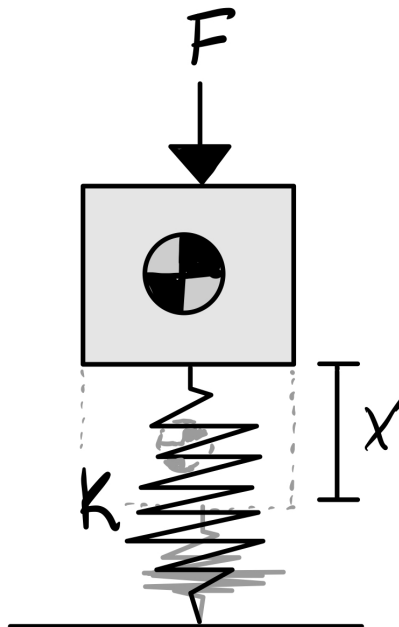

Figure 20: Schematic shows force diagram of spring and pressure plate system.

$$F_s = -k \cdot x \quad (1)$$

The known parameters of this device would be the force exerted on the pressure plate, or on the spring, and the displacement that is required. The only parameter left to solve for would be the spring constant. Hooke's Law will provide useful information for deciding the spring constant in the spring needed for the trap's pressure plate. Additionally, the pressure plate is a known device needed to actuate the system, another location that Hooke's Law could be helpful is for closing the door.

Force on Gear

In the worm drive system, the worm is "powered" by the spring compression force. Given this magnitude and the tangential force needed to rotate a gear through one full revolution, we can choose an appropriate worm gear with the right pitch circle diameter. Figure 21 shows a simplified model and Eq. 2 shows the relationships mentioned.

$$F_T = \frac{2\tau_{worm}}{d_{pitch}} \quad (2)$$

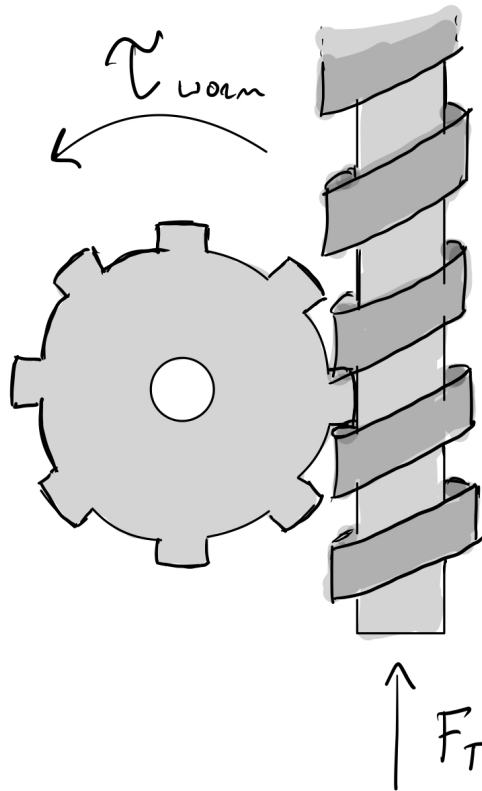

Figure 21: Schematic shows worm drive system

Testing for Torsional, Bending and Shear Load

The models need to be tested for torsional, bending, and shear loading to allow us to determine the most effective shape for the trap. Long travel times, length of use (the longer the better), robustness in handling, and moving the traps would be some reasons that would factor into the decision making of the shape for the trap.

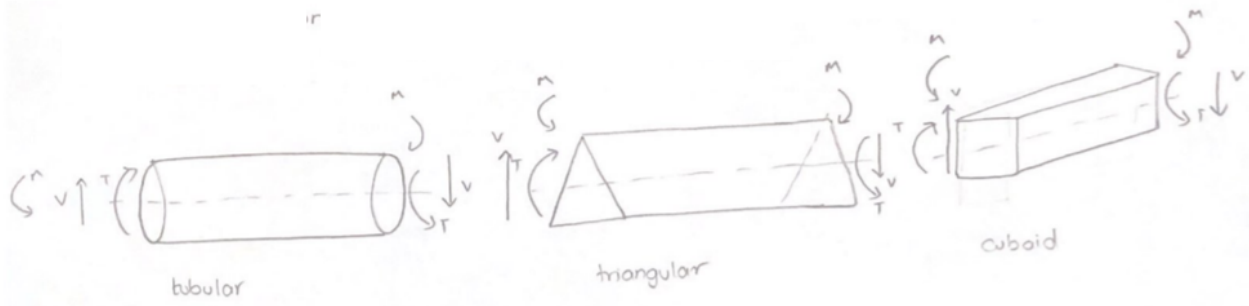

Figure 22: Schematic shows how the models will be tested for shear bending and torsional

The equations below are used to calculate the bending load, torsional load and shear load.

$$\sigma = \frac{-My}{I} \quad (3)$$

$$\tau = \frac{Tr}{J} \quad (4)$$

$$\sigma = \frac{P}{A} \quad (5)$$

The parameters given would include the force applied, the dimensions of the models used to be tested such as the length, mass, and diameter. The polar moment of inertia and the moment of inertia will be calculated.

Concept Embodiment

Initial Embodiment

The original prototype design uses a spring to power a rotary-pulley mechanism. This mechanism has an enclosed spring that will power the pulley. The pulley will move a string that is attached to the door. The door requires 7 inches of displacement through moving a string on one side. This distance can be reduced to 3.5 inches, or 0.0889 m, if the same string is being pulled on either sides. Using Hooke's Law in Eq. 6, spring constant, k , can be found so that type of spring required for the device is known. The force, F , needed to close the trap door is 4.4 N. This would give a spring constant of 49.49 N/m.

$$F = -kx \quad (6)$$

For this trap to actuate, a push plate must be moved by the rat. Therefore, it is useful to understand the work that needs to be done to the system. There are many characteristics that could affect the force required to move the push plate. The most common would be tension from the dowel pin and friction between the push plate and end cap track. The dowel pin is inserted into the door to hold it in an open position. Once the pin is removed, the door is able to fall. The displacement, s , required to release the door is 0.0075 m. The second revision of the prototype does not use a rotary device to open and close the door. Therefore, the force needed to remove the pin is much lower at 1 N. The frictional force from the track, F_s , is the product of a static friction coefficient and normal force. The track has PLA to PLA contact which gives a coefficient of friction of 0.492, and a normal force of 0.98 N [8]. Which means the frictional force is 0.48 N. Therefore, the total force required to move the push plate would be approximately 1.5 N. The work required to move the push plate would be 0.011 J.

$$W = F_s \quad (7)$$

The best way to reduce the force required is to reduce the static friction coefficient. PLA coated with Graphite 50% has shown a significant reduction in the static friction coefficient at 0.288 [8]. The frictional force, F_s , with graphite 50% is 0.28 N and a system force of approximately 1.4 N. Using Eq. 7, the work required to move the push plate at least 0.0075 N is 0.0096 J with graphite 50% coating opposed to 0.011 J, providing a 12.7% increase in ease of actuation. This is significant because the less work required to move the push plate will result in more efficiency in the system.

B

B

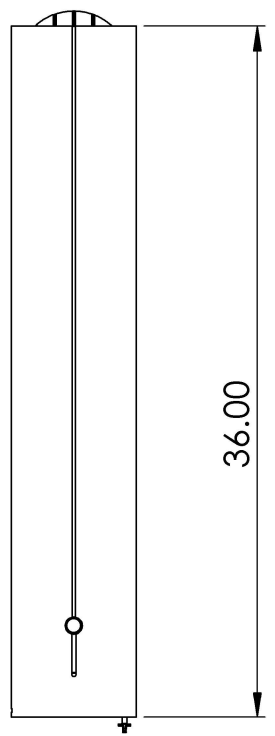

36.00

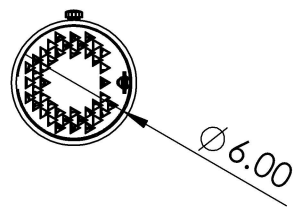

Ø 6.00

1

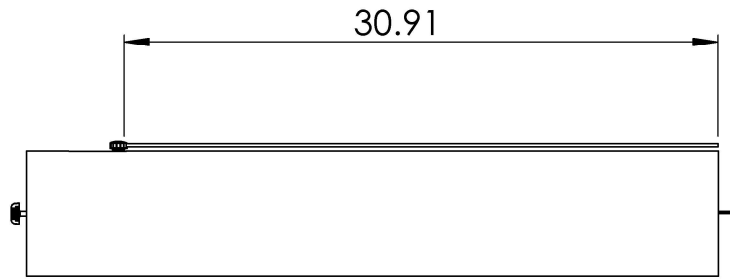

30.91

A

A

UNLESS OTHERWISE SPECIFIED:	
DIMENSIONS ARE IN INCHES	
TOLERANCES: ANGULAR: 1° TWO PLACE DECIMAL ±0.01 THREE PLACE DECIMAL ±0.005	
INTERPRET GEOMETRIC TOLERANCING PER:	
MATERIAL	
FINISH	
DO NOT SCALE DRAWING	

MEMS-411 Group Q		
TITLE: BBAR TRAP		
SIZE	DWG. NO.	REV
A	ASSEMBV3_ISO3	
SCALE: 1:10		SHEET 1 OF 1

2

1

2

1

ITEM NO.	PART NUMBER	DESCRIPTION	QTY.
1	mainbody	PVC	1
2	94188A210	Acetal Quarter-Turn Captive Panel Screw	1
3	endcap	PLA Filament	1
4	pushplate	PLA Filament	1
5	quarterturnsupport	Acrylic	1
6	91841A195	18-8 Stainless Steel Hex Nut	1
7	6479K32	Black Phenolic Plastic Knob	1
8	livinghingdoor	Nylon Filament	1
9	string	Nylon String	1
10	#10 bolt	Stainless Steel	6



UNLESS OTHERWISE SPECIFIED:

DIMENSIONS ARE IN INCHES

TOLERANCES:
 ANGULAR: 1°
 TWO PLACE DECIMAL ±0.01
 THREE PLACE DECIMAL ±0.005

INTERPRET GEOMETRIC
 TOLERANCING PER:

MATERIAL

FINISH

DO NOT SCALE DRAWING

MEMS-411 Group Q

TITLE:

BBAR TRAP

SIZE	DWG. NO.	REV
ASSEM	V3_BOM	

SCALE: 1:10

SHEET 1 OF 1

2

1

B

B

A

A

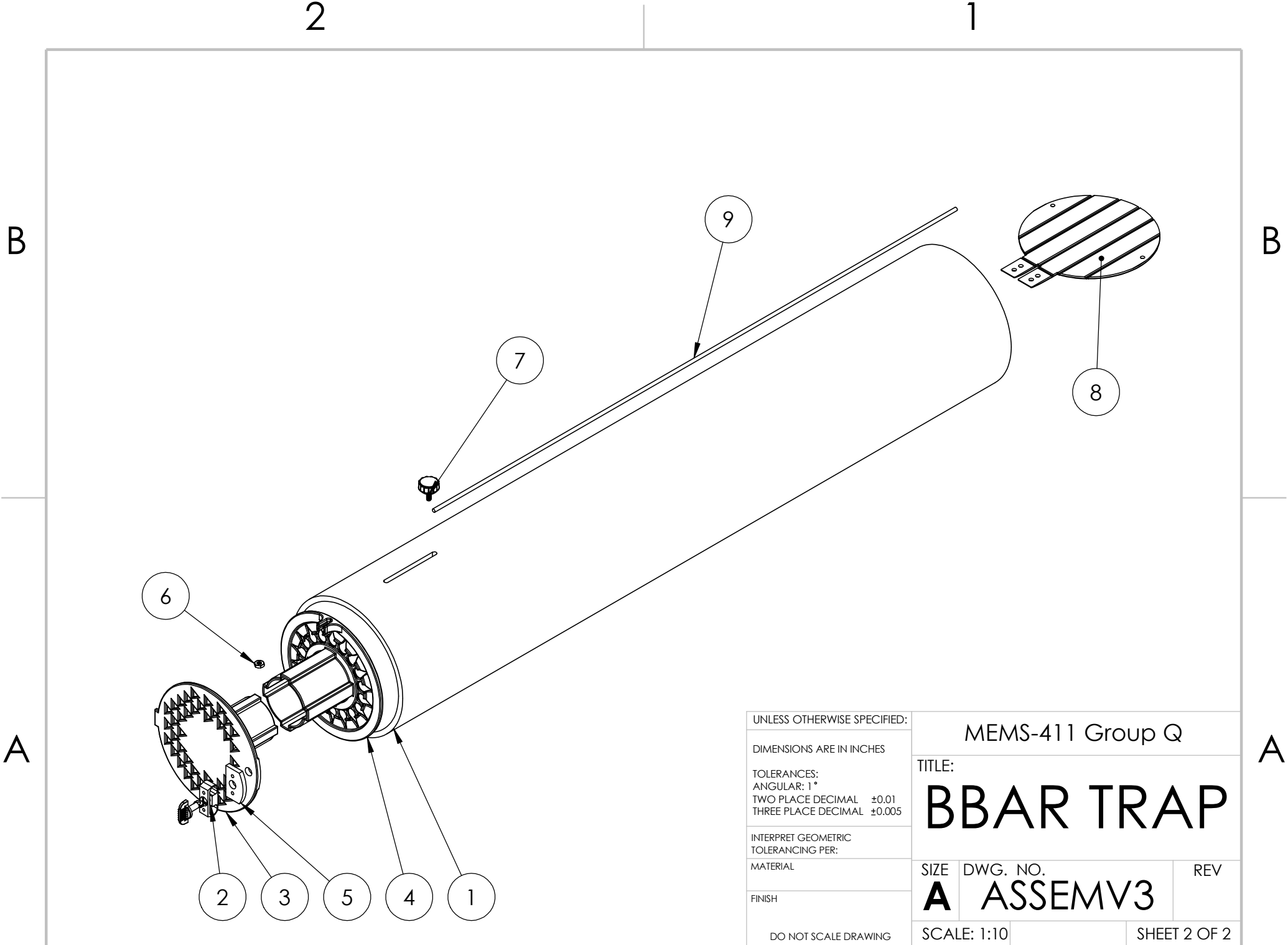

UNLESS OTHERWISE SPECIFIED:
 DIMENSIONS ARE IN INCHES
 TOLERANCES:
 ANGULAR: 1°
 TWO PLACE DECIMAL ±0.01
 THREE PLACE DECIMAL ±0.005
 INTERPRET GEOMETRIC TOLERANCING PER:
 MATERIAL
 FINISH
 DO NOT SCALE DRAWING

MEMS-411 Group Q		
TITLE: BBAR TRAP		
SIZE A	DWG. NO. ASSEMB3	REV
SCALE: 1:10		SHEET 2 OF 2

Proofs-of-Concept

Figures 23 and 24 show an earlier prototype of the Living Hinged door closed and opened respectively. The door has vertical slits, allowing it to conform to the shape of the pipe when opened. This gives the rat full access to the 6" diameter. When snapped shut, the door re-configures to a flat circle and completely closes off the rat's escape route.

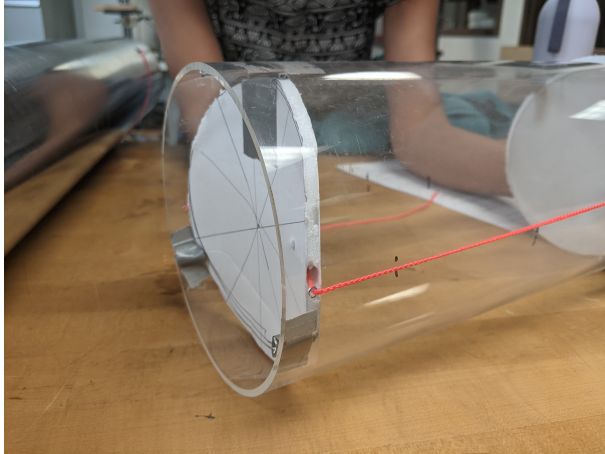

Figure 23: Live hinged door when closed

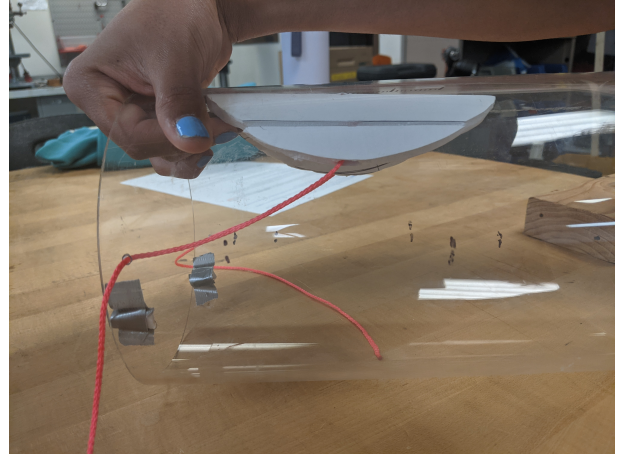

Figure 24: Live hinged door when opened

Figures 25 and 26 show the push paddle as seen from the end cap and the exterior respectively. When the rat interacts with the push paddle, the screws that are attached move back and trigger the rotary-pulley system to shut the door.

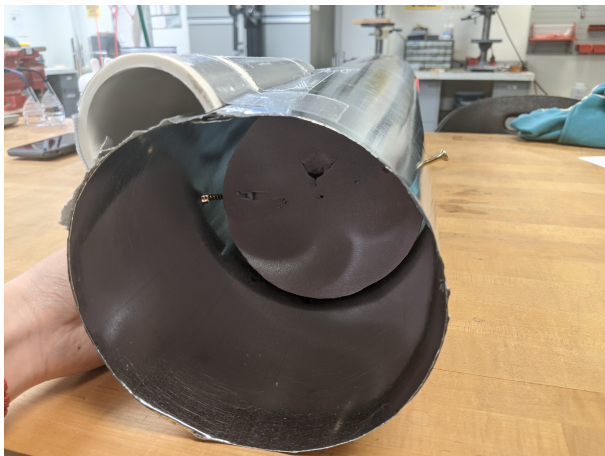

Figure 25: Isometric view of engaged push paddle viewed (with end cap removed)



Figure 26: Push paddle extensions viewed from outside of trap

Figure 27 shows the rotary-pulley system that actuates the trap. Its connection with the push paddle is not shown; however, there would be a stopper that fixes the orange pulley and black rotary in place. This stopper is attached to the screws on the push paddle. When the push paddle moves, the stopper comes out of the pulley, and the system actuates and closes the living hinged door.

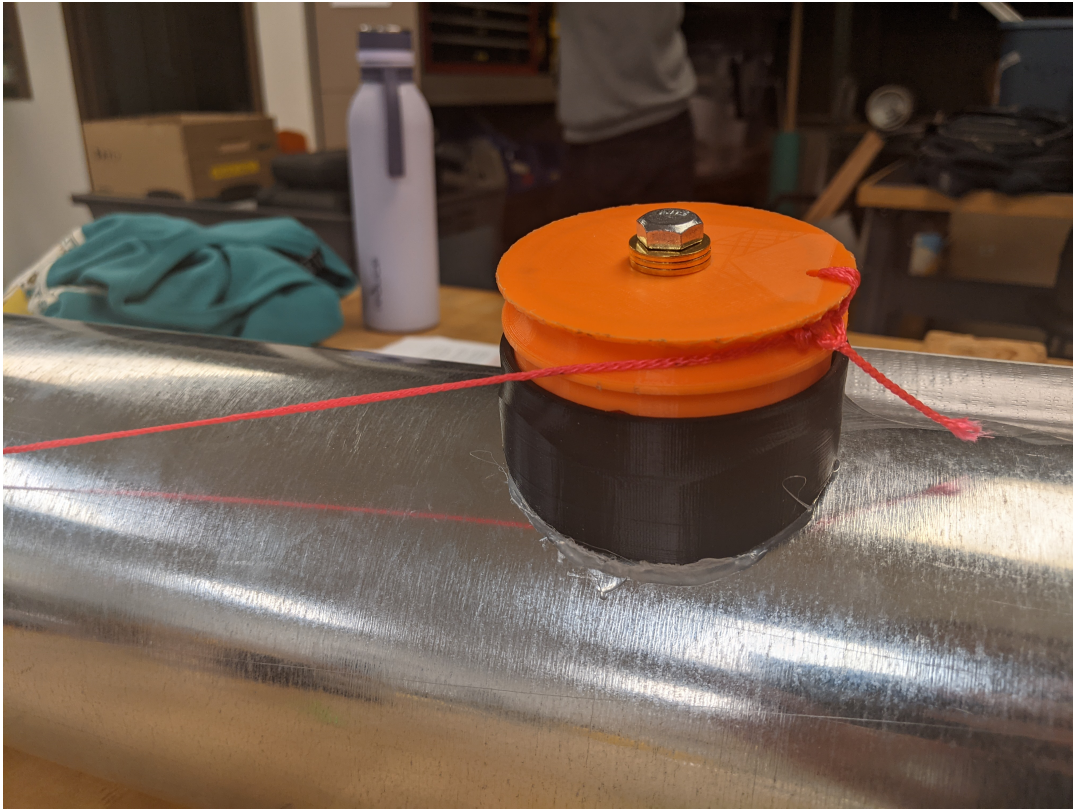

Figure 27: Rotary-pulley device attached to exterior of trap

Design Changes

To reduce the amount of working parts, we've decided to change the actuating mechanism from the rotary device to a Hodor system. The end of the door has an extruded part that comes up through the pipe when opened. A steel wire keeps the door open by going through a hole in the extruded part. This wire is attached to the pressure plate; therefore, actuating the door when the plate is engaged. The steel wire would be housed, leaving only the front section exposed. This allows the user to reactivate the trap by manually putting the steel wire into the door's extrusion.

We also modified the end cap of the trap to 1) hold the bait and 2) ensure the pressure plate moves in 1 dimension. The end cap will have a hollow cylindrical shape extruded out to house the bait. The back side of the pressure plate will have a matching extruded shape to serve as a sliding guide. When the pressure plate is fully pushed back, the rat will have full access to the bait. Additionally, the end cap is secured through a quarter turn fastener. This will ensure secure and easy access to the bait.

The material of the pipe has been changed from PVC to sheet metal. A standard PVC pipe that is 6" in diameter and 3' in length weighs well over 8 lbs, which does not meet our design goal. Sheet metal with the same dimensions weigh about 2 lbs. Our main concerns with this material change are 1) whether it would affect the Gambian rat's olfactory system and 2) whether the metal would absorb too much heat under testing conditions. We plan to meet with Dr. Braude to address these issues.

Design Refinement

Model-Based Design Decisions

Work done by Rat

To actuate our trap, a push plate must be moved by the rat. Therefore, it is useful to understand the work that needs to be done to the system. There are many characteristics that could affect the force required to move the push plate. The most common would be tension from the dowel pin and friction between the push plate and end cap track. The dowel pin is inserted into the door to hold it in an open position. Once the pin is removed, the door is able to fall. The displacement, s , required to release the door is 0.0075 m. The current revision of the prototype does not use a rotary device to open and close the door. Therefore, the force needed to remove the pin is much lower at 1 N. The frictional force from the track, F_s , is the product of a static friction coefficient and normal force. The track has PLA to PLA contact which gives a coefficient of friction of 0.492, and a normal force of 0.98 N [8]. Which means the frictional force is 0.48 N. Therefore, the total force required to move the push plate would be approximately 1.5 N. The work required to move the push plate would be 0.011 J.

$$W = F_s s \quad (8)$$

The best way to reduce the force required is to reduce the static friction coefficient. PLA coated with Graphite 50% has shown a significant reduction in the static friction coefficient at 0.288 [8]. The frictional force, F_s , with graphite 50% is 0.28 N and a system force of approximately 1.4 N. Using Eq. 8, the work required to move the push plate at least 0.0075 N is 0.0096 J with graphite 50% coating opposed to 0.011 J, providing a 12.7% increase in ease of actuation. This is significant because the less work required to move the push plate will result in more efficiency in the system.

Bending of PVC Pipe

Due to manufacturing constraints and customer needs, a standard 6" diameter Charlotte PVC pipe was chosen for our current revision. Bending, torsional, and shear stress were evaluated for previous prototypes; however, the current most relevant factor would be the max force the trap can withstand before failure. The 3-point bending equation is used to approximate this force, as shown in Eq. 9.

$$\sigma_f = \frac{FL}{\pi R^3} \quad (9)$$

Given that the outer diameter is 6.275" or 0.1594 m, the length of the trap is 3', and the flexural strength of Charlotte PVC pipe is 10.585 ksi [9], the max force supported before failure is 127 kN. It is safe to say that the material selection is more than appropriate to hold a Gambian pouched rat while under harsh environmental conditions. Note that the equation used was for a solid circular bar; however, it is still appropriate to approximate the range of detrimental forces.

Spring Stiffness to Raise Flag

Our current revision includes a spring-actuated flag to indicate a successfully captured rat. The spring is attached to the door; therefore, as the door closes, the spring is released and flings the flag pole upwards to a height of 3'. The flag pole and flag together weigh approximately 1 N.

Using Hooke's Law in Eq. 10, the minimum spring stiffness needed would be 1.2 N/m. Taking the relatively harsh environmental constraints into account, a spring stiffness of 50 N/m was chosen.

$$k = \frac{F}{x} \tag{10}$$

Design for Safety

Dr. Braude's requirements were the main objectives used in the design conceptualization of the rat trap. In addition, safety features were added to ensure a risk-free utilization of the trap for both user and the rat. An analysis of possible risks with the prototype were determined. Each risk was categorised based on the severity of risk and the probability that the risk will go wrong. Five potential risks were identified and given a severity and probability based on possible impact for the user and/or the rat. The list below gives the five risks in descending order of severity of risk and highest priority. The steps taken or that could be taken to mitigate the problem are also given under each risk.

Figure 28 shows the five risks as it would appear on a heat map.

		Probability that something will go wrong				
Category		Frequent Likely to occur immediately or in a	Likely Quite likely to occur in time	Occasional May occur in time	Seldom Not likely to occur but possible	Unlikely Unlikely to occur
Severity of risk	Catastrophic					
	Critical	standard 6 inch PVC tube is very thick				the trap door attachment to the tube coming apart
	Marginal		spring holding the flag stick down			
	Negligible hazard presents a minimal threat to safety, health, and well-being of participants; trivial			the tube breaking	external moving parts on the trap	

Figure 28: Heat Map of different risks identified in the rat trap

Risk #1: The thickness of a standard 6 inch PVC pipe

Description: 3 ft of the 6 inch tube for the trap will be considerably heavy especially with the trapped rat and could cause eventual back pains for those collecting the rat traps after capture

Severity: Critical

Probability: Frequent

Mitigating Steps: A green Charlotte PVC tube (ASTM D 3034) will be used as it has a thinner wall (about $\frac{1}{3}$ the thickness of a standard white 6 in. PVC tube)

Risk #2: Spring holding the flag stick down used as a signal

Description: The spring is triggered by the closing of the door to make the flag stick vertical. A small trigger could release the spring and get in the users face while setting the trap or moving the trap

Severity: Marginal

Probability: Likely

Mitigating Steps: Ensure that the flag mechanism is secure in holding it down and only triggered when the door closes and also paying attention to the mechanism when handling the device

Risk #3: The trap door attachment to the tube breaking away from the tube

Description: This would allow an easy escape for the rat and if the tube is being collected and the door comes apart then the rat could potentially seriously harm the user

Severity: Critical

Probability: Unlikely

Mitigating Steps: The living hinge door is designed to ensure that it is securely attached to the tube so that after the mechanism is triggered, it would securely close the door until the handler releases the rats after capture

Risk #4: The tube breaking/deforming

Description: The tube breaking, deforming due to improperly securing the traps while traveling and moving the traps. Breaking of the plastic could produce sharp pieces.

Severity: Negligible

Probability: Occasional

Mitigating Steps: Ensure that the traps are securely packed especially when travelling across rough terrain and using a material like PVC that is strong and flexible

Risk #5: External moving parts on the trap

Description: The external parts and protrusions could cause minor cuts if user is being abrasive with handling the rat trap

Severity: Negligible

Probability: Seldom

Mitigating Steps: The protrusions will be covered with a casing to prevent entanglement from vegetation as well as any accidents

Design for Manufacturing

The following components in the current design of the trap include:

- ▶ 6" PVC Pipe
- ▶ End Cap
- ▶ Push Plate
- ▶ Living Hinge Door
- ▶ Stopper
- ▶ Quarter Turn Base
- ▶ Quarter Turn Key
- ▶ End Cap Support
- ▶ Hex Nut
- ▶ Lock Washer
- ▶ Washer
- ▶ Bolt
- ▶ Release Pin

Of these components the four that must be separate pieces are the 6" PVC Pipe, End Cap, Push Plate, and the Living Hinge Door. Each of these pieces have a unique and connected function in trapping the rat. First, the PVC pipe provides the necessary and smooth housing to hold the rat after it has been trapped. Second, the End Cap ensures that that trap is closed off from one side. This provides a convenient and functional location for bait, and is removable so that the user can add bait with ease or service the trap. Third, the push plate allows for the actuation of the trap. Without this component, the door would not be able to close when the rat enters the trap. Finally, the Living Hinge door closes the entrance to the trap. The living hinge components allow the door to conform to the inner surface of the trap. This allows for larger rats to enter the trap.

The bolt is included as a TNC, as it has a function. That function is to connect the door to the push plate. As the push plate moves, string attached to the bolt will move with it. This results in the string pulling a dowel out of a hole in the door. The door, now unrestricted, will spring shut from the force of the living hinges. The bolt, which includes a lock washer, washer, and nut, could potentially be reduced down to an extrusion that is part of the push plate. This would reduce the number of TNCs from five to one with respect to the push plate.

Another way to reduce the number of TNCs is in the Quarter turn assembly with the End Cap. There is a support fastened to the PVC pipe. The Quarter Turn Base is fastened to the support. The End Cap is then secured to the support and base by installing the Quarter Turn Key. This assembly can be reduced to three components from four by combining the base and support.

Design for Usability

Vision Impairment

The rat trap is designed with intricate components. Thus, poor vision would make it difficult to reset the traps in low lighting (at night). Carrying a flashlight would help overcome this issue. Another issue that would arise is using visual observation to check if a rat is caught. Initially, it was proposed by Dr. Braude to paint the door a neon color. However this could be a problem for researchers with color-blindness. To rectify this issue, a small flag connected to stick will be attached to the trap door. As the trap door closes the flag will go up. Blue and orange are considered to be color blind friendly thus we will be using an orange stick with a blue flag. In addition to the colors, the physical flag standing vertically will allow for a easier observation to check if that rat is captured.

Hearing Impairment

Capturing the rats require a relatively quiet surrounding; thus, the rat trap does not have components that make any audible signals. A person with a hearing impairment would not influence the usability of the rat trap.

Physical Impairment

The rat trap is designed such that there is a small dowel pin that needs to be placed back into a small opening to reset the door. This requires the user to have the mobility and ability to move fingers intricately. Repeated setting of the traps would be difficult for someone with arthritis as this can cause flares in the joints. A solution for someone with a physical impairment would be to design the trap door mechanism such that it resets itself after the rats are released from the traps.

Control Impairment

The rat trap has a relatively simple design with little to no unnecessary moving parts. Also, as part of the requirements, the trap has no sharp edges, protrusions or anything that would injure the rat. This also would not injure the user due to the smooth features of the trap. Thus a person having control impairment would not influence the usability of the rat trap.

Final Prototype

Overview and Final Render

The final revision of this trap uses a low number of moving parts and solid state parts. The main body includes a Charlotte Thin Walled PVC Pipe, the Living Hinge Door, Door Supports, Dowel Pin, Quarter Turn Assembly, Push Plate, and End Cap which are 3D printed from PETG. The bolt and nuts are 1/4 inches in diameter and 2 inches in length

The Living Hinge Door has been optimized into two pieces that are secured together with adhesive. This ensures accountable and repeatable manufacturability. The Living Hinge Door, when closed, is flat and flush with the entrance of the tube. The Door Stoppers are attached around the edge to ensure that the door cannot be pushed outward when closed. When open, the Living Hinge Door

conforms to the curved surface of the tube. This gives access to the full 6” of the inner diameter of the tube to be used, which allows for larger male rats and pregnant female rats to be captured.

The door naturally rests in a closed position due to a spring force generated by the living hinges against the body of the tube. The trap is held in an open position by a Dowel Pin. When this pin is removed the door will spring shut.

The pin is connected to a bolt on the opposite end of the trap by a string. This bolt is constrained in a slot and secured to the Push Plate. The Push Plate rides concentrically on rails on the outside of a designated location for food. This is a hollow cylinder attached to the end cap for food, bait, or paste to entice the rat to enter the trap.

The food is inaccessible when the Push Plate is fully extended. Therefore, it is necessary for the rat to move the Push Plate forward to reach the food. The total distance the Push Plate will move from an extended state to a compressed state is 1.5 inches. The required distance to remove the Dowel Pin from the door release is 0.25 inches. Consequently, the food will be accessible only after the pin is released.

Lastly, the End Cap is secured to the body by a single Quarter Turn Assembly. This allows for easy access to the designated food area, quick clean up, maintenance, or replacing parts if necessary. The extruded cylinder on the entrance side of the trap is for a flag attachment. This will be released as the door is shut to signify that the trap has been set off. The trap requires very little work from the user to set and very little work from the rat to actuate.

Documentation

Below are renderings of the trap in different environments, and under different configurations.



Figure 29: Rendered photo of the Q.T. B-BAR Rat Trap at a closed state in the environment



Figure 30: Rendered photo of the Q.T. B-BAR Rat Trap with a clear body at a closed state in the environment



Figure 31: Side view of the Q.T. B-BAR Rat Trap in an opened state. Note how the Dowel Pin is in the door release and the Push Plate is fully extended

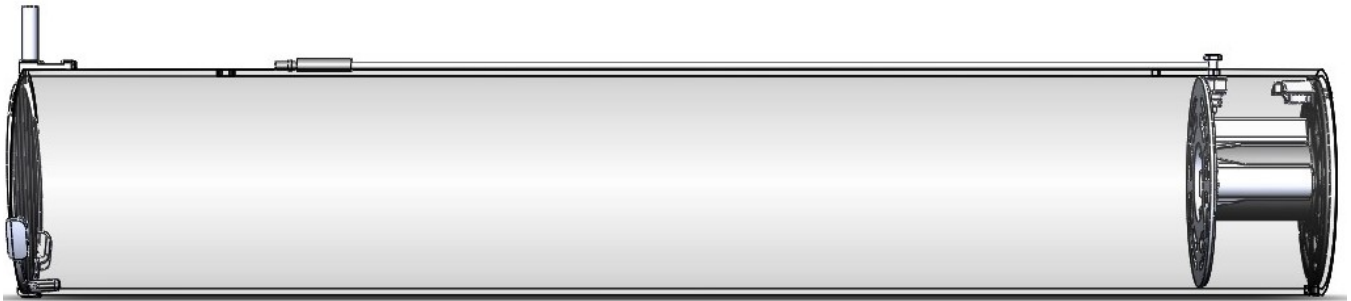
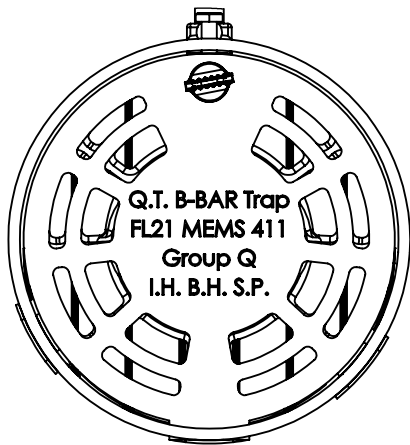
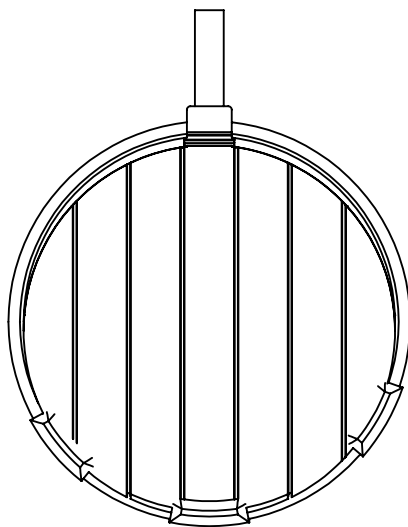
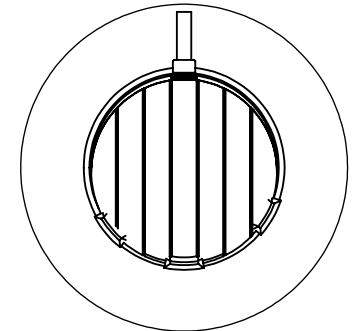
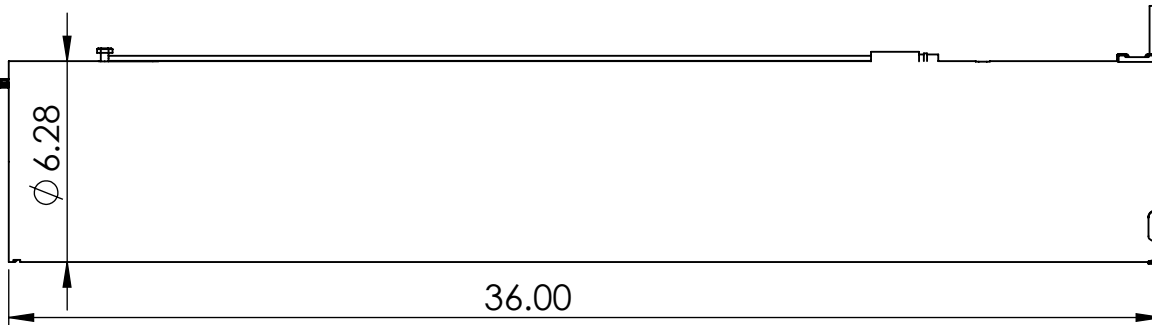
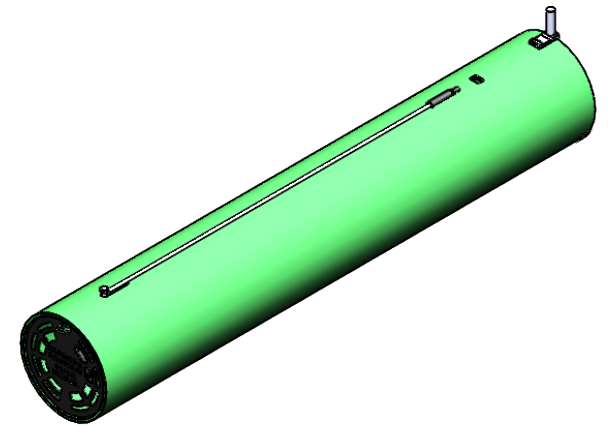

Figure 32: Side view of the Q.T. B-Bar Rat Trap in a closed state. Note how the Push Plate is compressed and Dowel Pin has been removed from the door release.



DETAIL A
SCALE 1 : 3



DETAIL B
SCALE 1 : 3

UNLESS OTHERWISE SPECIFIED:

DIMENSIONS ARE IN INCHES

TOLERANCES:
ANGULAR: 1°
TWO PLACE DECIMAL ±0.01
THREE PLACE DECIMAL ±0.005

INTERPRET GEOMETRIC
TOLERANCING PER:

MATERIAL

FINISH

DO NOT SCALE DRAWING

MEMS-411 SENIOR DESIGN

TITLE:

Q.T. B-BAR - FULL

SIZE	DWG. NO.	REV
A	RT-1001-21-ASSEM	V4

SCALE: 1:20

SHEET 1 OF 1

2

1

ITEM NO.	PART NUMBER	DESCRIPTION	QTY.
1	RT-0001-21 - 6-INCH PVC PIPE	6 Inch Charlotte Thin Walled	1
2	RT-1002-21 - END CAP	PETG	1
3	RT-1003-21 - PUSH PLATE	PETG	1
4	RT-2002-21 - DOWEL PIN	PETG	1
5	RT-3001-21 - QUARTER TURN, BASE	PLA	1
6	RT-3005-21 - QUARTER TURN, KEY	PLA	1
7	RT-3007-21 - HEX NUT, 1-4 20		2
8	RT-3008-21 - HEX BOLT, QUATER INCH		1
9	RT-3009-21 - WASHER, QUARTER		1
10	RT-3010-21 - LOCKWASHER, QUARTER		1
11	RT-2001-21 - LIVING HINGE DOOR		1
12	RT-2002-21 - LIVING HINGE, HINGE	PETG	1
13	RT-2003-21 - STOPPER		3
14	RT-6001-21 - STRING	Nylon String	1

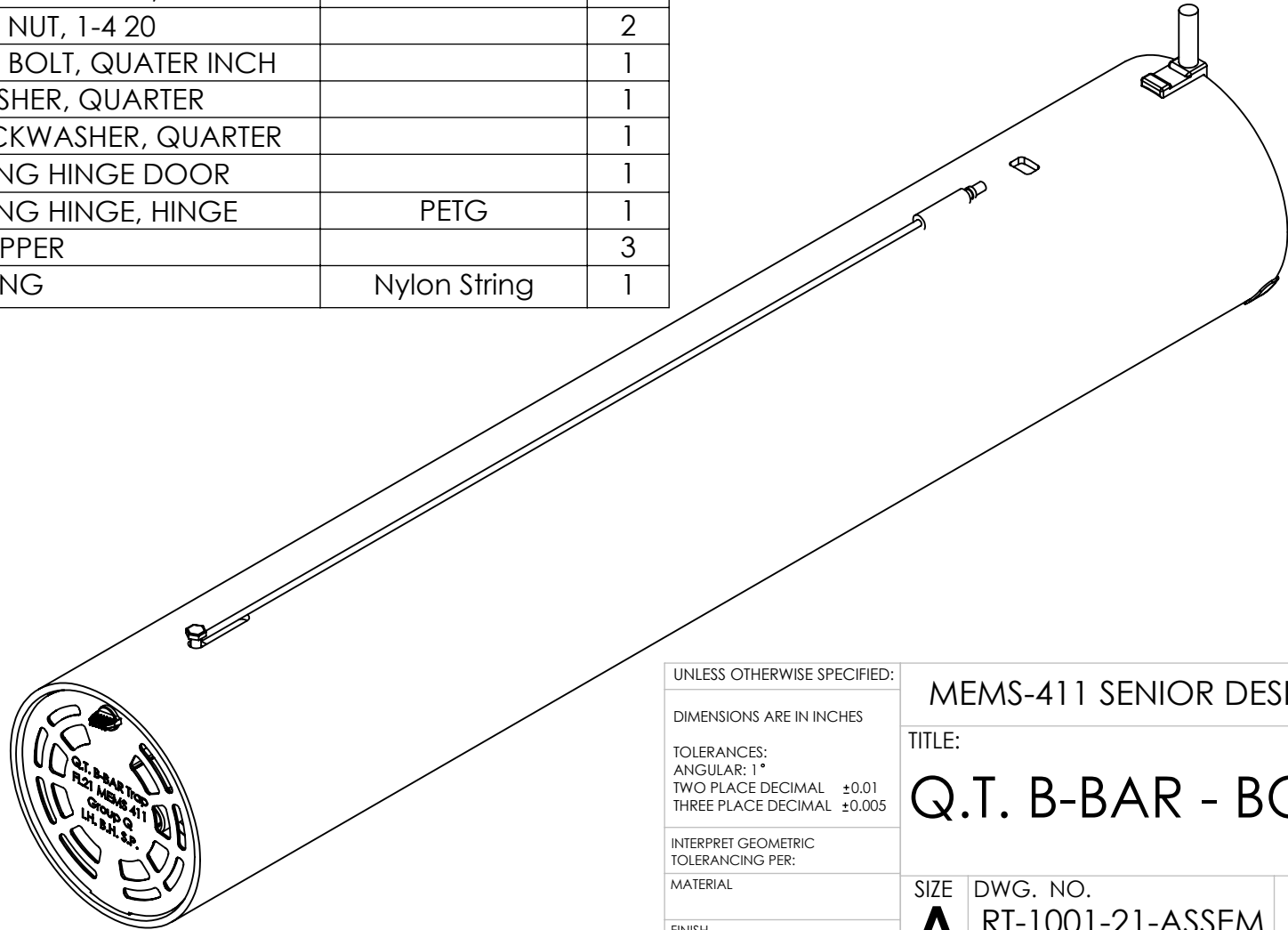

UNLESS OTHERWISE SPECIFIED:

DIMENSIONS ARE IN INCHES

TOLERANCES:
 ANGULAR: 1°
 TWO PLACE DECIMAL ±0.01
 THREE PLACE DECIMAL ±0.005

INTERPRET GEOMETRIC
 TOLERANCING PER:

MATERIAL

FINISH

DO NOT SCALE DRAWING

MEMS-411 SENIOR DESIGN

TITLE:

Q.T. B-BAR - BOM

SIZE

A

DWG. NO.

RT-1001-21-ASSEM

REV

V4

SCALE: 1:10

SHEET 1 OF 1

2

1

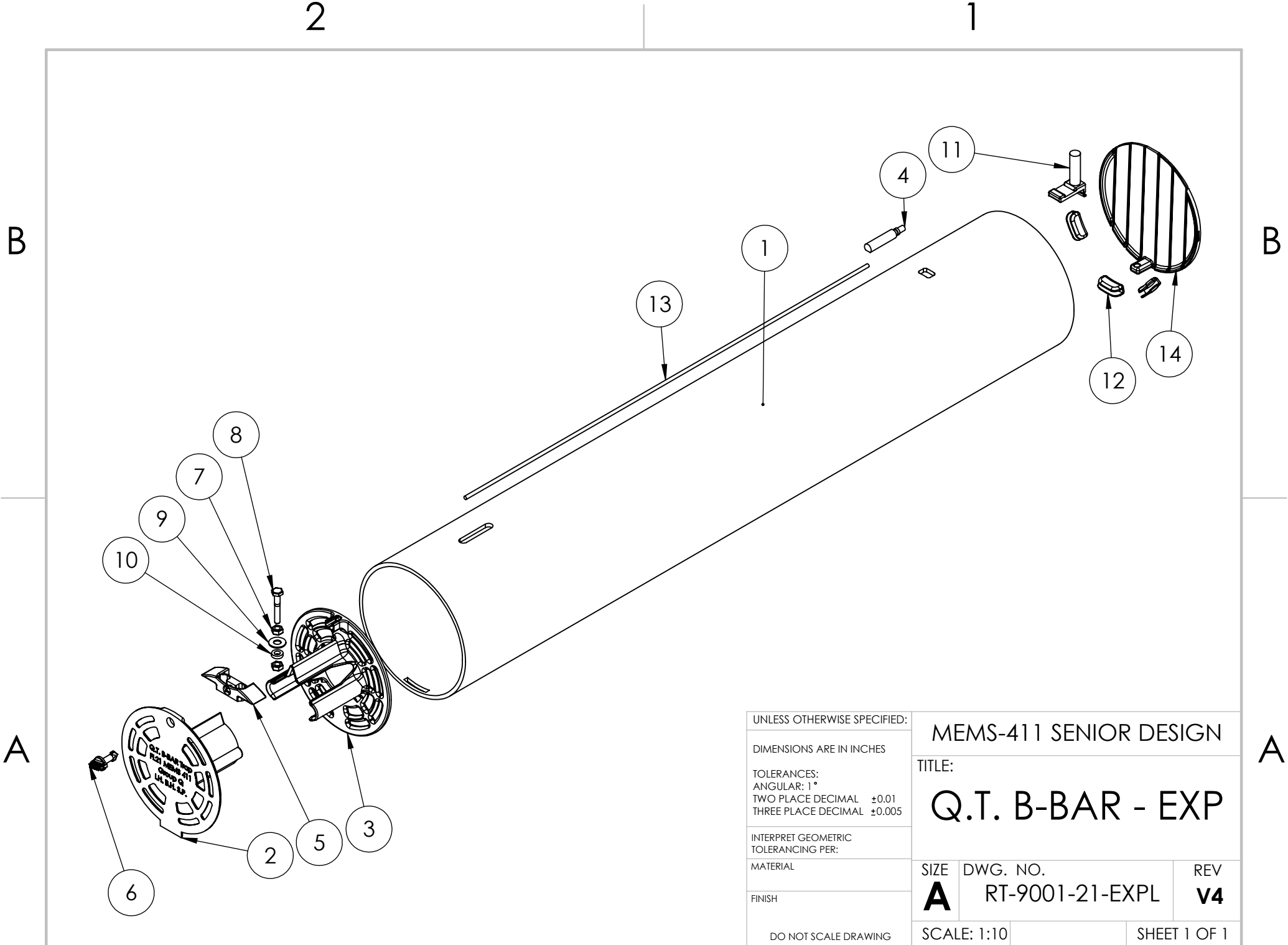

UNLESS OTHERWISE SPECIFIED:
 DIMENSIONS ARE IN INCHES
 TOLERANCES:
 ANGULAR: 1°
 TWO PLACE DECIMAL ±0.01
 THREE PLACE DECIMAL ±0.005
 INTERPRET GEOMETRIC
 TOLERANCING PER:
 MATERIAL
 FINISH
 DO NOT SCALE DRAWING

MEMS-411 SENIOR DESIGN
 TITLE:
Q.T. B-BAR - EXP
 SIZE DWG. NO. REV
A RT-9001-21-EXPL **V4**
 SCALE: 1:10 SHEET 1 OF 1

Assembled Model

The final prototype of the assembled model is shown below. It is assembled using the parts and build instructions from Appendix A and Appendix B.



(a) End Cap view



(b) Door view

Figure 33: Q.T. B-BAR Rat Trap in a closed and released state



(a) End Cap view



(b) Door view

Figure 34: Q.T. B-BAR Rat Trap in a opened and engaged state

Bibliography

- [1] Home Team Pest Defense. *Inventors Month Who Invented the Mouse Trap*. URL: <https://pestdefense.com/inventors-month-who-invented-the-mouse-trap/> (visited on 07/01/2021).
- [2] Smart Flip Trap. *Smart Flip Trap Bucket Lid Rat Trap*. URL: <https://tinyurl.com/97x4rr38> (visited on 07/13/2021).
- [3] Gingbau. *Gingbau Live Chipmunk Trap Humane Rat Mouse Cage Trap*. Product. URL: <https://www.amazon.com/Gingbau-Chipmunk-Humane-Rodent-Animals/dp/B07G2LRSRV>.
- [4] Edward Holliday Christopher Rich Robert Cruz and Marko Lubic. *Cage Trap with Easy Set and Release Mechanism*. US Patent #9060505. 2012. URL: <https://patents.justia.com/patent/9060505>.
- [5] William E Askins. *Cage Traps*. US Patent #5862624. 1996. URL: <https://patents.justia.com/patent/5862624>.
- [6] International Organization fro Standardization. *Unplasticized polyvinyl chloride (PVC) pipes and fittings*. URL: <https://www.iso.org/obp/ui/#iso:std:iso:4439:ed-1:v1:en> (visited on 07/13/2021).
- [7] MakerBot PLA. *Safety Data Sheet - PLA 3D Printer Filament/ MakerBot PLA*. URL: <https://images.makerbot.com/support/production/SDS-000002ENA.pdf> (visited on 07/13/2021).
- [8] Wojciech Pawlak. *Wear and Coefficient of Friction of PLA-Graphite Composite in 3D Pringing Technology*. 24th International Conference Engineering Mechanics 2018. 2018. URL: <https://www.engmech.cz/improc/2018/649.pdf>.
- [9] Plastics Technical Manual. *Physical Properties of Charlotte Pipe ABS and PVC Materials*. URL: <https://www.mtncom.net/store-files/spec-sheets/Charlotte%5C%20pipe/Charlotte%5C%20PVC%5C%20DWV%5C%20manual.pdf> (visited on 08/16/2021).

A Parts List

Table A.1: Parts list for the Q.T. B-BAR Rap Trap

ITEM NO.	PART NO.	DESCRIPTION	QTY.	Cost
1	RT-0001-21 - 6-INCH PVC PIPE	6 Inch Charlotte Thin Walled	1	\$13.94
2	RT-1002-21 - END CAP	PETG	1	\$2.22
3	RT-1003-21 - PUSH PLATE	PETG	1	\$1.78
4	RT-2002-21 - DOWEL PIN	PETG	1	\$0.13
5	RT-3001-21 - QUARTER TURN, BASE	PLA	1	\$0.19
6	RT-3005-21 - QUARTER TURN, KEY	PLA	1	\$0.05
7	RT-3007-21 - HEX NUT, 1/4 20	Steel, 1/4-20	2	\$0.18
8	RT-3008-21 - HEX BOLT, QUARTER INCH	Steel, 1/4-20	1	\$0.13
9	RT-3009-21 - WASHER, QUARTER INCH	Steel, 1/4	1	\$0.13
10	RT-3010-21 - LOCKWASHER, QUARTER INCH	Steel, 1/4-20	1	\$0.13
11	RT-2001-21 - LIVING HINGE DOOR	PETG	1	\$1.36
12	RT-2002-21 - LIVING HINGE, HINGE	PETG	1	\$0.20
13	RT-2003-21 - STOPPER	PLA	3	\$0.21
14	RT-6001-21 - PUSH BAR	ALUMINUM	1	\$0.75
15	RT-6002-21 - RELEASE CAP	PLA	1	\$0.07
Total Cost:				\$21.47

B Build Instructions

How To Assemble the Trap:

1. Gather all of the necessary components
 - ▶ Assembled tube
 - ▶ End Cap
 - ▶ Push Plate
 - ▶ Quarter Turn
 - ▶ Assembled Living Hinge Door
 - ▶ Door Fastener
 - ▶ Bolt, washer, lock washer, and nuts
 - ▶ Bolt Cap
 - ▶ Dowel Pin
 - ▶ Flag and Flag Base [Optional]
 - ▶ Trap stands [Optional]
2. Begin by setting the tube in a horizontal orientation on a flat surface, if you have trap stands, you can use these.
3. Put the Push Plate inside the tubing
4. Assemble the release mechanism in the Push Plate by securing a bolt through the PVC Tube with the provided washers, lock washers, and nuts.
5. Apply bait to the End Cap
6. Position the Push Plate and End Cap concentrically and slide the End Cap into position
7. At a slight angle, put the End Cap Tab into the slot on the PVC Pipe
8. Now secure the End Cap with a the provided Quarter Turn
9. At this point, the fixated end of the tube should be completely assembled
10. Place the Living Hinge Door inside of the tube just inside of the stoppers at the other end.
11. Secure the extruded hinge of the Living Hinge Door with the provided fastener to the outside of the PVC tubing so that the door will align with the release cut out. [Optional]: Add flag base if needed.
12. Take the push rod and slide it through the exterior housing located at the top of the tube
13. Connect the end to the bolt on the Push Plate.
14. At this point, the trap is fully assembled.
15. To engage the trap, please follow the instructions *How To Engage the Trap*
16. To disassemble the trap, please follow these instructions in reverse order.

How To Engage the Trap:

1. First, ensure that the trap is fully assembled per the instructions *How To Assemble the Trap*
2. Open the Living Hinge Door, such that the extrusion will fit through the release hole.
3. Put the Dowel Pin through this hole
4. If there is a flag secured, bend the flag over and secure the flag release to the Bolt Cap
5. At this point, the trap is engaged

How To Reapply Bait to the Trap:

1. After the trap is set off, new bait may need to be applied
2. Release the quarter turn and take out the End Cap
3. Reapply bait to the End Cap
4. Position the Push Plate and End Cap concentrically and slide the End Cap into position
5. At a slight angle, put the End Cap Tab into the slot on the PVC Pipe
6. Now secure the End Cap with a the provided Quarter Turn
7. At this point, the fixated end of the tube should be completely assembled
8. To engage the trap, please follow the instructions *How To Engage the Trap*