

Washington University in St. Louis

## Washington University Open Scholarship

---

Mechanical Engineering Design Project Class

Mechanical Engineering & Materials Science

---

Fall 2016

### Reinventing the Dishwasher

Caryn Devaney

*Washington University in St. Louis*

Carter Fraser

*Washington University in St. Louis*

Aaron Walters

*Washington University in St. Louis*

Follow this and additional works at: <https://openscholarship.wustl.edu/mems411>



Part of the [Mechanical Engineering Commons](#)

---

#### Recommended Citation

Devaney, Caryn; Fraser, Carter; and Walters, Aaron, "Reinventing the Dishwasher" (2016). *Mechanical Engineering Design Project Class*. 50.

<https://openscholarship.wustl.edu/mems411/50>

This Final Report is brought to you for free and open access by the Mechanical Engineering & Materials Science at Washington University Open Scholarship. It has been accepted for inclusion in Mechanical Engineering Design Project Class by an authorized administrator of Washington University Open Scholarship. For more information, please contact [digital@wumail.wustl.edu](mailto:digital@wumail.wustl.edu).



Washington University in St. Louis

SCHOOL OF ENGINEERING & APPLIED SCIENCE

Most people aren't excited to do the dishes. Still, washing cookware like pots and pans is an unavoidable task - and even those who own dishwashers typically choose to handwash them after use. After conducting a wide-ranging market survey, we designed a standalone device which can fill the existing gap between handwashing and dishwashing. We successfully built a single pan dishwasher which simulates hand washing to clean nonstick frying pans.

---

# MEMS 411

## Reinventing the Dishwasher

---

### Automatic Hand-Washing Dishwasher

---

Caryn Devaney  
Carter Fraser  
Aaron Walters

---

**TABLE OF CONTENTS**

List of Figures .....	4
List of Tables .....	6
1 Introduction.....	7
1.1 Project problem statement.....	7
1.2 List of team members.....	7
2 Background Information Study – Concept of Operations.....	7
2.1 A short design brief description that describes the problem .....	7
2.2 Summary of relevant background information .....	8
3 Concept Design and Specification – Design requirements .....	8
3.1 Operational requirements allocated and decomposed to design requirements.....	8
3.1.1 Record of the User Needs Interview .....	8
3.1.2 Functional Allocation and Decomposition.....	10
3.2 Four concept drawings .....	11
3.3 Concept Selection Process .....	14
3.3.1 Concept Scoring.....	14
3.3.2 Preliminary analysis of each concept’s physical feasibility based on design requirements, function allocation, and functional decomposition .....	15
3.3.3 Final Summary .....	16
3.4 Proposed Performance Measures for the Design .....	16
3.5 Design Constraints .....	17
3.5.1 Functional .....	17
3.5.2 Safety .....	17
3.5.3 Quality.....	17
3.5.4 Manufacturing.....	17
3.5.5 Timing.....	17
3.5.6 Economic .....	17
3.5.7 Ergonomic.....	17
3.5.8 Ecological .....	18
3.5.9 Aesthetic .....	18
3.5.10 Life Cycle.....	18
3.5.11 Legal .....	18
4 Embodiment and Fabrication Plan.....	19
4.1 Embodiment Drawing.....	19

4.2	Parts List .....	20
4.3	Draft Detailed Drawings for Each Manufactured Part.....	22
4.4	Description of the design rationale for the choice/size/shape of each part .....	22
4.5	Gantt chart.....	24
5	Engineering Analysis .....	26
5.1	Engineering Analysis Results .....	26
5.1.1	Motivation.....	26
5.1.2	Summary Statement of Analysis Done .....	26
5.1.3	Methodology .....	27
5.1.4	Results.....	28
5.1.5	Significance.....	28
5.1.6	Summary of Code and Standards and their Influence.....	30
5.2	Risk Assessment .....	30
5.2.1	Risk Identification.....	30
5.2.2	Risk Impact or Consequence Assessment.....	31
5.2.3	Risk Prioritization .....	31
6	Working Prototype.....	31
6.1	Final Demonstration of the Working Prototype.....	31
6.2	Photographs of Prototype.....	32
6.3	Video of Prototype .....	32
6.4	additional photographs and explanations .....	33
7	Design Documentation.....	35
7.1	Final Drawings and Documentation .....	35
7.1.1	Engineering Drawings.....	35
7.1.2	Sourcing Instructions .....	35
7.2	Final Presentation.....	35
7.2.1	Presentation.....	35
7.2.2	Link to Project Video.....	36
7.3	Teardown .....	36
8	Discussion.....	36
8.1	How well were the needs met in the final prototype?.....	36
8.2	Discuss any significant parts sourcing issues – delivery time, scrounging?.....	37
8.3	Discuss the Overall Experience .....	37

8.3.1	Was the project more or less difficult than you had expected?.....	37
8.3.2	Does the final project align with the project description?.....	37
8.3.3	Did your team function well as a group? .....	37
8.3.4	Were your team members' skills complementary? .....	37
8.3.5	Did your team share the workload equally?.....	37
8.3.6	Was any needed skill missing from the group? .....	38
8.3.7	Did you have to consult with your customer during the process, or did you work to the original design brief? .....	38
8.3.8	Did the design brief (as provided by the customer) seem to change during the process?...	38
8.3.9	Has the project enhanced your design skills? .....	38
8.3.10	Would you now feel more comfortable accepting a design project assignment at a job?...	38
8.3.11	Are there projects that you would attempt now that you would not attempt before? .....	38
9	Appendix A – Selected Market Research .....	39
10	Appendix B – Parts List .....	41
11	Appendix C – Bill of Materials.....	44
12	Appendix D – CAD models of Fabricated Parts .....	45
13	Appendix E – SolidWorks Report .....	49
14	Appendix F – Arduino Code .....	56
15	Annotated Bibliography .....	58

**LIST OF FIGURES**

Figure 1 Bar Glass Cleaner .....	8
Figure 2 EasyGo Manual Portable Dishwasher .....	8
Figure 3 Operational Requirements .....	9
Figure 4 Design Requirements.....	10
Figure 5 Design 1: Overhanging sink dishwasher .....	11
Figure 6 Design 2: Vertical feeding dishwasher .....	12
Figure 7 Design 3: Automatically adjusting brush dishwasher (note: pan and brush should be oriented vertically) .....	13
Figure 8 Design 4: “Stand mixer” style brush dishwasher .....	14
Figure 9 Initial embodiment proposal.....	19
Figure 10 Gantt Chart Part 1 .....	24
Figure 11 Gantt Chart Part 2.....	25
Figure 12 Simulation of applied force on brush backing, 6” diameter pan .....	26
Figure 13 Simulation of applied force on brush backing, 14” diameter pan .....	27
Figure 14 Visualization of applied force on brush from pan .....	27
Figure 15 Existing prototype brush design .....	29
Figure 16 Proposed brush design modifications from analysis results – isometric view.....	29
Figure 17 Proposed brush design modifications from analysis results - side view.....	30
Figure 18 Risk Assessment Heat Map .....	30
Figure 19 Pan (approximately 8” diameter) loaded into prototype.....	32
Figure 20 Washing area showing nozzle setup and brush .....	32
Figure 21 Power supply for pump, motor, and Arduino.....	33
Figure 22 Mechanism for keeping pan secured .....	33
Figure 23 Changing brush to accommodate pans of different diameters.....	34
Figure 24 Top button runs a single cycle, with red indicating cycle in process and green indicating cycle is done. Bottom button runs only pump until the top button is pressed to turn it off. ....	34
Figure 25 Back view showing motor platform and submersible pump in chamber .....	35
Figure 26 Teardown Agreement with Professor Jakiela.....	36
Figure 27 Teardown Agreement with Professor Malast .....	36
Figure 28 Market Research: Age Results Figure 29 Market Research: Income Results .....	39
Figure 30 Market Research: Cookware Type .....	39
Figure 31 Market Research: Cookware Material .....	39
Figure 32 Market Research: Cookware Cleaning Habits.....	40
Figure 33 Market Research: Desired Size.....	40
Figure 34 Market Research: Removeable Brush Response .....	40
Figure 35 Market Research: Initial Interest .....	40
Figure 36 Back Cage.....	45
Figure 37 Bottom Support .....	45
Figure 38 Front Cover.....	46
Figure 39 Wet Washing Cage.....	46
Figure 40 Motor Platform .....	47
Figure 41 Motor Platform Support.....	47
Figure 42 Sloped Drain.....	48

Figure 43 Waterproof Wall..... 48

**LIST OF TABLES**

Table 1 Design Metric Analysis..... 14  
Table 2 Preliminary Parts List ..... 20  
Table 3 Final Cost Accounting Workbook ..... 41  
Table 4 Final Bill of Materials..... 44



## **1 INTRODUCTION**

### **1.1 PROJECT PROBLEM STATEMENT**

One of the most often used tools in a residential kitchen is the cook's favorite pot or pan, but many dread washing the dishes by hand. Even those who own a dishwasher often chose to handwash their cookware, whether due to space issues in the dishwasher or due to the aggressive methods used in modern dishwashers. Dishwashers aren't necessarily run after each meal, but a certain pot or pan may be needed for both lunch and dinner, requiring an immediate wash. By the end of our project we hope to have created a device that will simulate hand washing and allow these kinds of cookware to be mechanically washed. With our timeline and budget in mind, we narrowed our scope to successfully complete the project within one semester. Nonstick frying pans are used nearly every day in many kitchens, but few people know that their coatings may be damaged if subjected to the high temperature and pressure inside a dishwasher. Therefore, we have decided to focus on successfully cleaning nonstick pans with our prototype.

### **1.2 LIST OF TEAM MEMBERS**

Caryn Devaney  
Carter Fraser  
Aaron Walters

## **2 BACKGROUND INFORMATION STUDY – CONCEPT OF OPERATIONS**

### **2.1 A SHORT DESIGN BRIEF DESCRIPTION THAT DESCRIBES THE PROBLEM**

During this project we must design a device that costs under \$300 and can simulate hand washing for a non-stick pan sized 6"-14 in in diameter in under 1 minute. The device must be about the size of a microwave and should fit on a typical countertop in the kitchen. Because there is water involved in the process we must figure out a way to spray water onto the surface of the pan while keeping all electrical components dry. It will require little input from the user other than a process like loading a dishwasher – placing the pan in, pressing a button, and removing the pan.

## 2.2 SUMMARY OF RELEVANT BACKGROUND INFORMATION

There currently no pre-existing device similar to our proposed design. We took slight inspiration a bar glass cleaner, shown in Figure 1, in terms of using a bristled brush for scrubbing.



**Figure 1 Bar Glass Cleaner**

We also found a manual dishwasher, shown in Figure 2, which we also determined was not a comparable device to ours other than the bristles used for cleaning.



**Figure 2 EasyGo Manual Portable Dishwasher**

## 3 CONCEPT DESIGN AND SPECIFICATION – DESIGN REQUIREMENTS

### 3.1 OPERATIONAL REQUIREMENTS ALLOCATED AND DECOMPOSED TO DESIGN REQUIREMENTS

#### 3.1.1 Record of the User Needs Interview

Due to the wide range of possible design choices for our device, we concluded that it was more effective to conduct a broad market research study rather than a single user needs interview. We sent out a Google survey and received 77 responses. They came from a wide range of demographics– college aged to over

50 years old, with annual incomes ranging from less than \$10,000 to over \$200,000 - which was important since our device has a wide target demographic. We asked 27 questions in total, covering a broad range of aspects which could affect our final design, from operation to storage to cost. The most significant results are shown in Appendix A – Selected Market Research. We used these informative responses to develop our operational requirements, as shown in Figure 3.

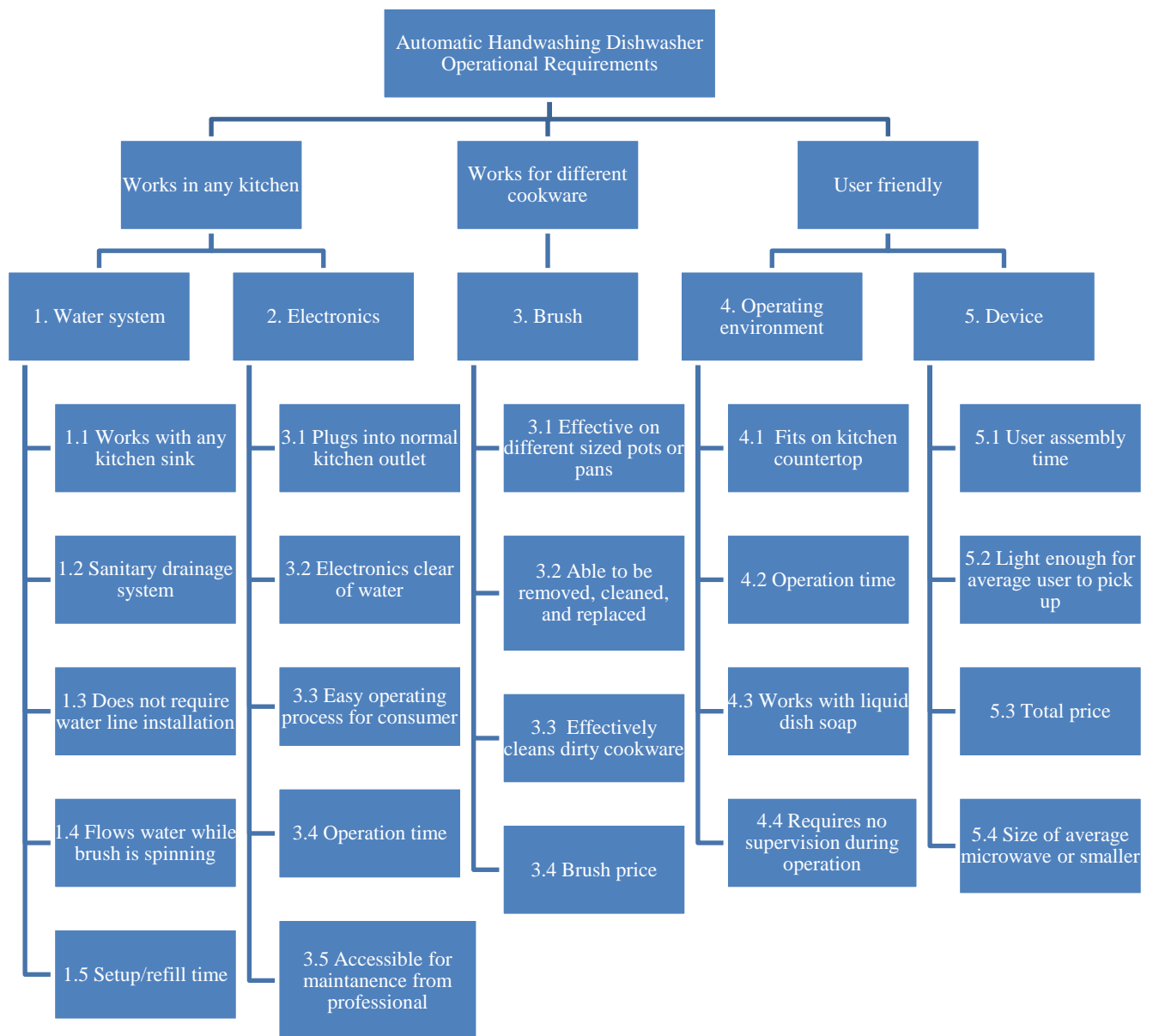

**Figure 3 Operational Requirements**

A diagram of the corresponding design requirements is shown in Figure 4.

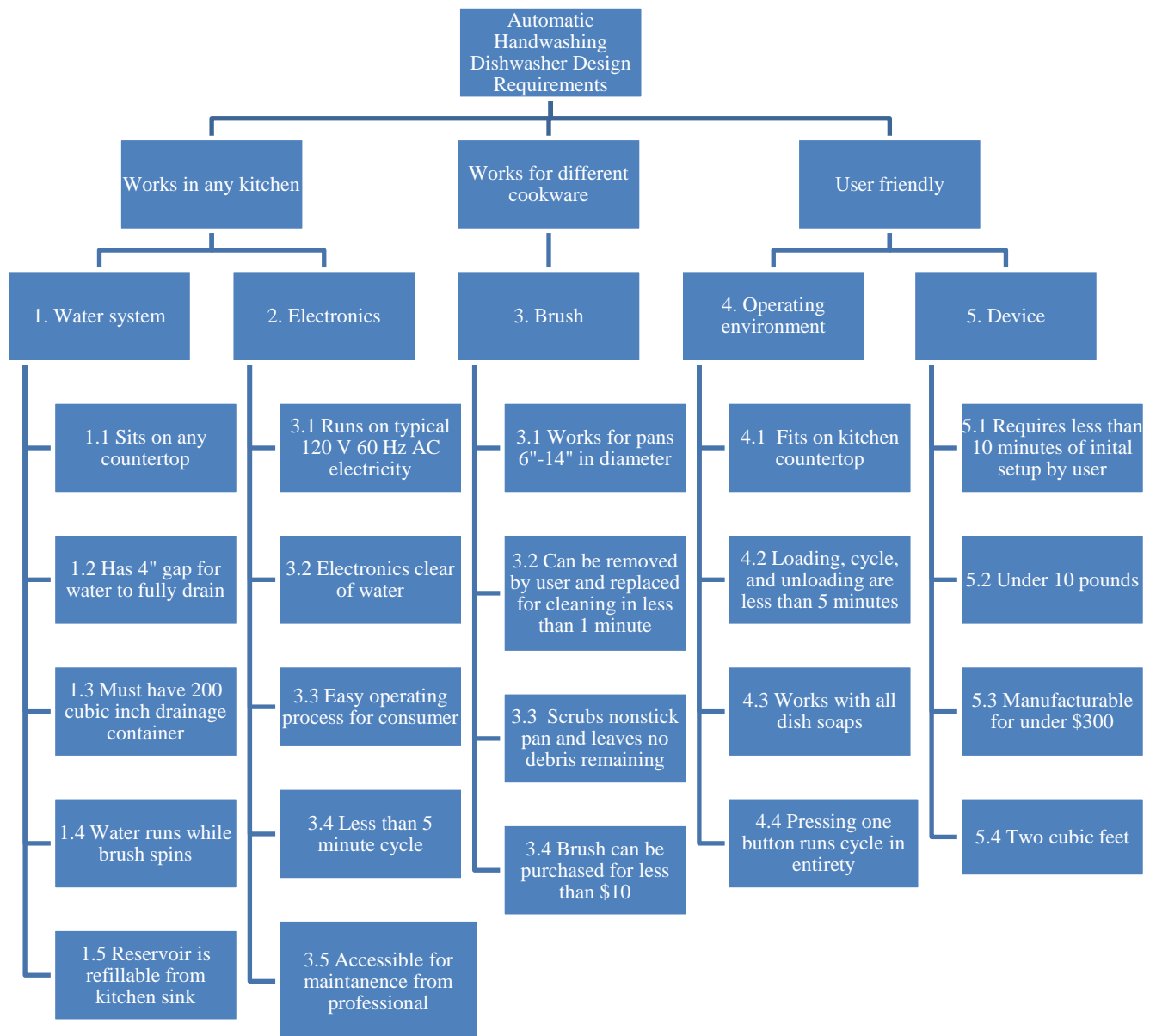

**Figure 4 Design Requirements**

### 3.1.2 Functional Allocation and Decomposition

The design requirements were obtained from the operational requirements by considering the time, budget, and skill constraints our group faced, while satisfying the market survey results. For example, we

knew that the brush design would be dependent on what size and finish our pans were. Although we had initially hoped to include cast iron and pots in our scope, we ruled them out after seeing the overwhelming popularity of nonstick pans and realized the time and money required to design such a complex brush. We established quantitative values that would allow us to gauge whether we fully completed our project goal when our prototype was built.

### 3.2 FOUR CONCEPT DRAWINGS

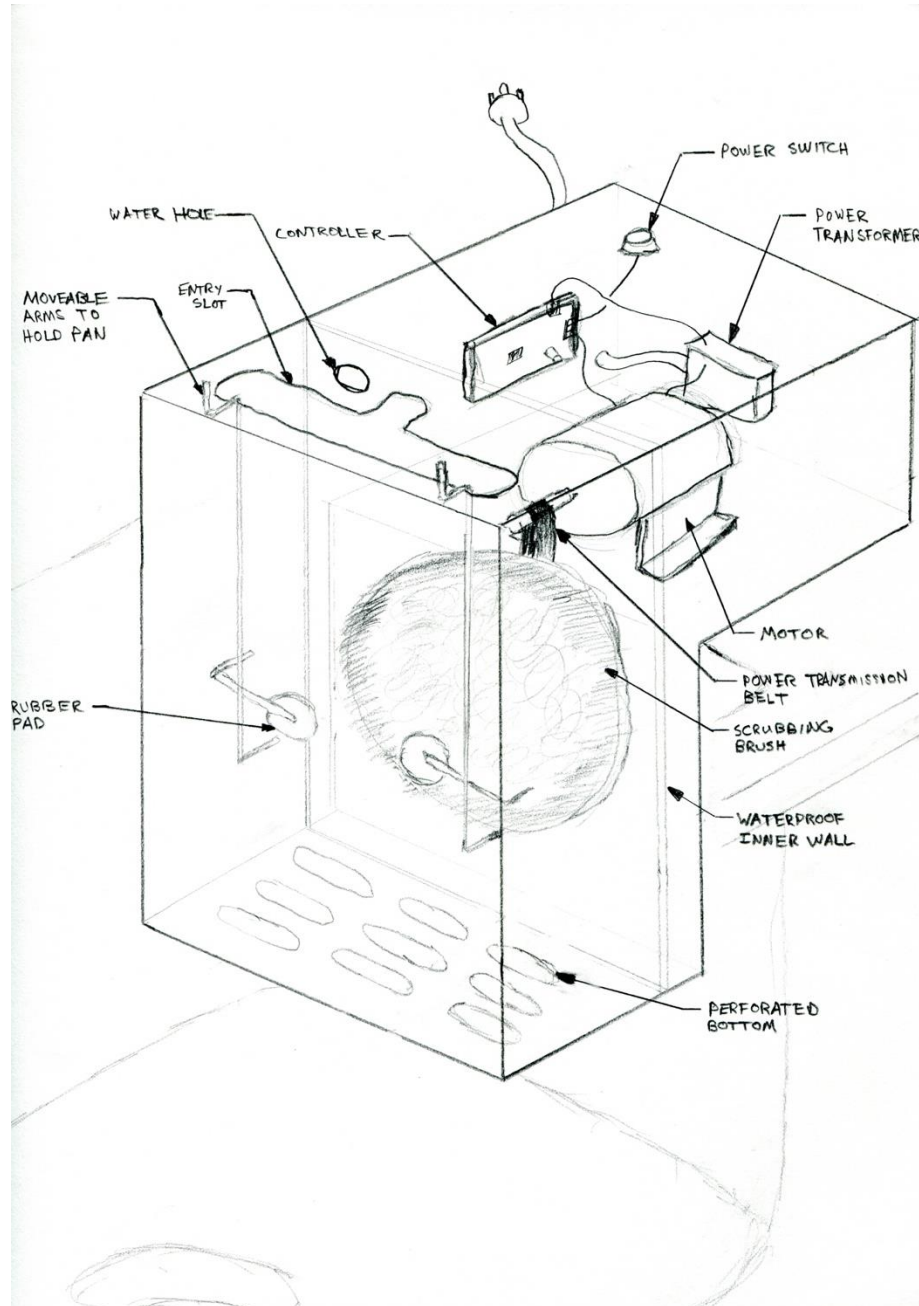

Figure 5 Design 1: Overhanging sink dishwasher

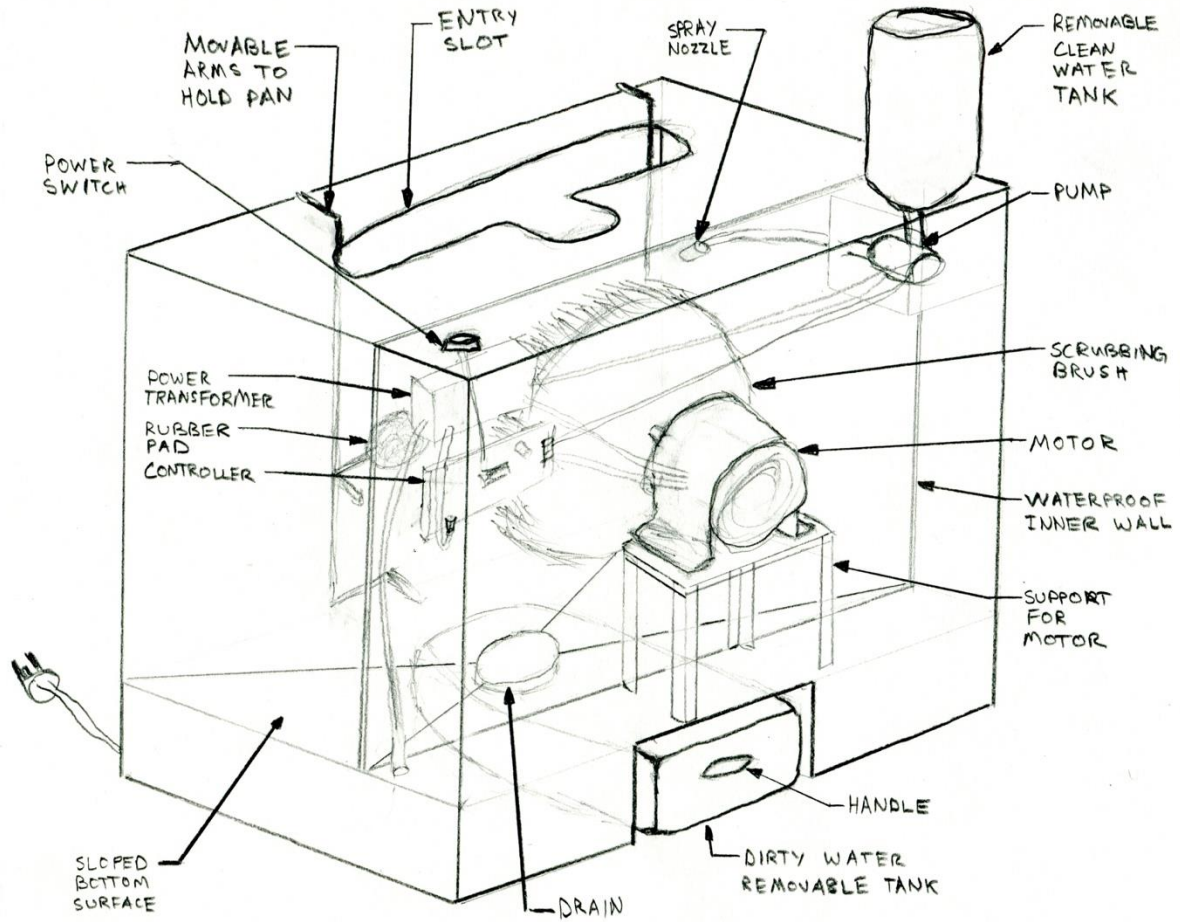

Figure 6 Design 2: Vertical feeding dishwasher

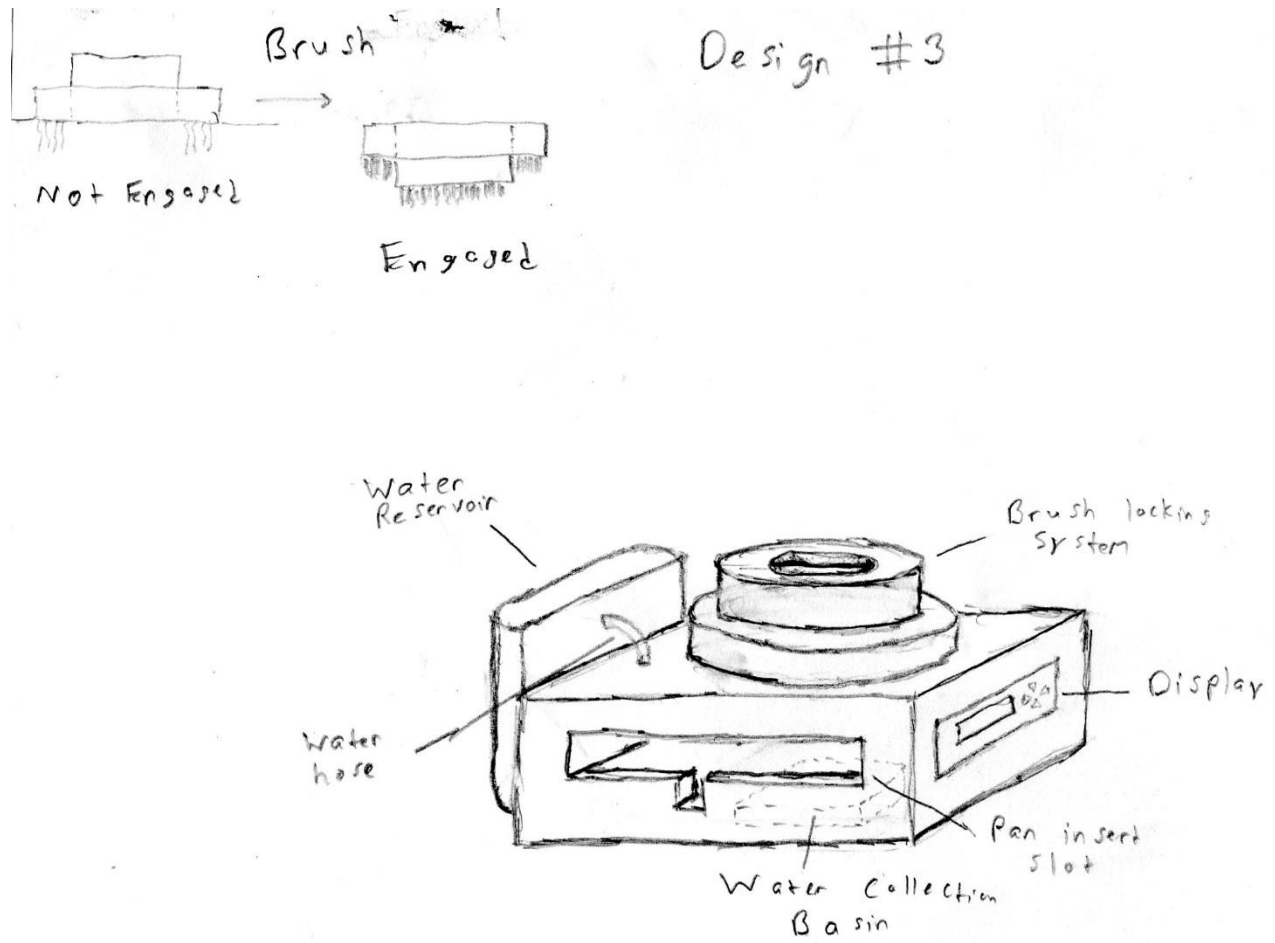

Figure 7 Design 3: Automatically adjusting brush dishwasher (note: pan and brush should be oriented vertically)

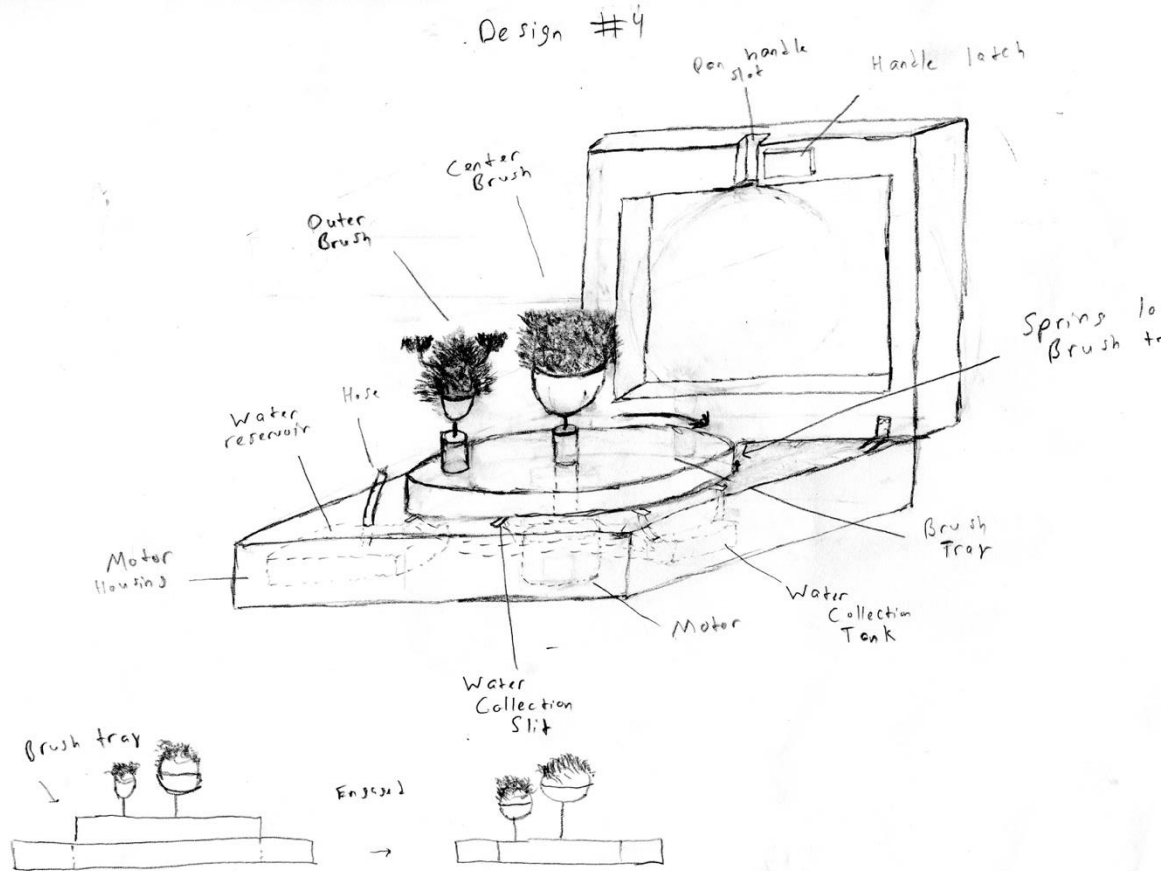

Figure 8 Design 4: “Stand mixer” style brush dishwasher

### 3.3 CONCEPT SELECTION PROCESS

#### 3.3.1 Concept Scoring

Table 1 Design Metric Analysis

Metric (all goals scored 1 to 5 for each design)	1. Overhanging Sink	2. Vertical Feeding	3. Adjusting Brush	4. Stand Mixer
Works with any kitchen	2	5	5	5
Drainage/disposal of dirty water	5	3	2	1
Does not require water line installation	5	5	5	5
Plugs into normal kitchen outlet	5	5	5	5
Electronics not near water	2	4	3	1
Ease of operation for user	2	2	3	4
Setup/refill time	5	3	3	3
Runs through cycle quickly	4	4	4	3
Accessibility for maintenance	3	2	2	4
Effective of many sized pots and pans	3	2	3	5



Brush easy to remove and clean	2	2	3	4
Brush simplicity/cost effectiveness	2	2	1	5
Total size	2	3	3	3
Works with liquid dish soap	3	3	4	3
Requires no supervision during use	1	5	4	5
Total weight	5	4	3	2
Total simplicity/cost effectiveness	5	3	1	2
<b>Total</b>	<b>56</b>	<b>57</b>	<b>54</b>	<b>60</b>

### 3.3.2 Preliminary analysis of each concept's physical feasibility based on design requirements, function allocation, and functional decomposition

#### 1. Overhanging sink dishwasher (Figure 5)

The brush will be belt driven, which makes the building of this prototype slightly more difficult. However, this is preferred to a direct drive in this case to maximize the distance between the water and the motor. As with all the designs, the electronics are at risk of coming into contact with water, but because of the close proximity to the sink in this design, that risk is even higher. Part of the device could even become submerged in water in the sink if the device was not operated properly, which could create a significant electrical hazard if grounding was faulty.

Taking into account the user's needs, this design is less likely to work for some customers, due to the intended location. It requires available countertop space next to the sink, and also protrudes a significant distance into the sink itself, so if the user has a smaller kitchen sink, they will wish to store the device when not in use. Storage will be complicated by the device being an odd shape and also will have a wet exterior. However, this design is more alluring for those who dislike coming into contact with dirty dishes or dirty water, because it simply allows the water to drain out into the sink with no manual emptying of a collection tray. It also does not use any water storage tanks, which makes it both cheaper and lighter.

#### 2. Vertical feeding dishwasher (Figure 6)

This design works for differently sized pans by allowing the user to force the pan flush with the brush bristles, and the slot secures the handle in place so that it operates autonomously. The width of the device will need to be wide in order to accommodate different depths of pots, and this is not ideal for some consumers, as many want the device to fit on their countertop. In general, this design is less flexible to different sized cookware than other designs. This design results in the lowest chance of water coming into contact with the electronics, as the motor and controls are separated by a solid wall from the spraying water and collection tray.

The brush head will need to be specially designed so that the brushes on the inside are stiff, and the ones on the outside adapt to different diameters of cookware. In this design the brush is difficult to access, which makes cleaning and replacement of the brush difficult. However, the direct drive system of coupling the brush to the motor reduces engineering complexity, reducing cost, weight, and maintenance compared to the in-sink design.

#### 3. Automatically adjusting brush dishwasher (pan and brush should be oriented vertically) (Figure 7)

This design allows for easy manual manipulation in order to accommodate different pot or pan depths. It will require a more specially designed brush-head, so that the inner diameter is

adjustable with an external handle in order to reach the bottom of the pot. This brush design will be more difficult to manufacture with more moving parts than the other static brush heads. It also will require fibers of different stiffness, so that the bristles on the edge are flexible enough to adapt to different diameters, but stiff enough to effectively scrub. The water system will be automatically controlled, so that the water will only be flowing when necessary to rinse the brush and pan off. This will require programming and adjustment for the timing to be correct. In addition, a water pump will be needed to slightly pressurize the water so that it effectively rinses the debris into the dirty water reservoir.

It does not require opening up the unit to remove the brush and has no “door,” making this design is the potentially the lowest profile of any of the devices. The electrical components are connected via a belt to the brush heads, giving some level of separation between electrical components and water, but not quite ideal. Overall, the greatest concern with this device is that the brushing mechanism is needlessly complicated, difficult to design, and would likely add cost.

#### 4. “Stand mixer” style brush dishwasher (Figure 8)

A significant issue with this design will be avoiding water contacting any electronics, as the pan drains directly over the operating motor. The housing for the motor and any wiring under the pan must be securely waterproofed, while still allowing the brush to touch the inside of the pan. The collection tray for the dirty water must also be significantly lower than the motor and electronics so that there is no chance of them sitting in the collected water. On the rotating platform, there will be two brushes with different flexibilities. The inner brush is stiffer, to scrub the middle of the pan, and the outer brush is wide and flexible so that it can fit in the corners of different sized pots no matter the radius. The pan or pot handle will “snap” into place on the hinged lid, and then is lowered to establish contact between the pan and the bristles. We will need to ensure that some pressure is created between the pan and the brushes, so that it is effectively scrubbed, but not too much pressure that it restricts the spinning of the brush. This pressure can be applied one of two ways. The first method involves spring loading the brush tray so that when the pan is locked into place the brushes lower down into the base by about half an inch but will remain in contact with the pan surface. The second method makes use of a locking mechanism on the upper wall of the device. When engaged this mechanism will force the pan against the brushes ensuring an adequate amount of pressure.

### 3.3.3 Final Summary

We ultimately chose to combine the vertical setup of Design 2 with the loading mechanism of Design 4. It is too risky to orient the pan horizontally and have it drain directly above the electronics. Attaching the pan in the manner of Design 4 ensures that the bottom surface will consistently come into contact with the bristles, no matter the diameter of the pan. This leads to our largest design question of how exactly the brush will be designed. We knew that it would come down to a lot of trial and error, since we were going to building the brush from “scratch” – bristles cut from other brushes and inserted into some type of backing.

## 3.4 PROPOSED PERFORMANCE MEASURES FOR THE DESIGN

- Cleans single 6”-14” non-stick pan
- Runs cycle in under 1 minute
- User friendly for residential cooks
- Does not require special space or installation by plumber or electrician
- Does not need to dry pan
- Less than 2 cubic feet

## 3.5 DESIGN CONSTRAINTS

### 3.5.1 Functional

Our device size was determined by our market analysis. Our potential consumers determined that the device should be about the size of a microwave so that it could fit into the average kitchen. The shape of the device was mainly determined by the maximum pan size and functionality of the device. The presence of the electronics and water reservoir heavily influenced this in that the need to separate the two increased the size of the device and the shape of the rear housing. There was also a need for a water reservoir at the base of the device, a feature that greatly increased the height of the device.

### 3.5.2 Safety

Operationally the main hazard that we dealt with was the danger of mixing water and electronics. To mitigate this risk, the water reservoir was purposefully located on the opposite side of the device. Our device also has moving parts which may pose a risk to the user. If we were to take the device to market, we would include a feature that ensured that the motor would not operate unless the front panel was secured. All electrical wires would also have to be inaccessible to the user.

### 3.5.3 Quality

The reliability of the device should be comparable to that of a dishwasher which has a life of about 7-12 years. The device is expected to fail if it is subjected to significant shocks such as a drop from the kitchen counter. Most of the device will be waterproofed such that low levels of water exposure should not damage the device. While the brushes will be dishwasher safe they will be subject to the most wear and will probably have to be replaced yearly due to fraying of the bristles.

### 3.5.4 Manufacturing

The production of the components will be relatively straight-forward. Most of the parts would be modeled and produced using durable plastics and light metals. The only part that poses a challenge is the brush, which will have to be custom made. There are currently no brush designs on the market that would fulfill our needs. Most of the assembly would be done using strong adhesives, welding, and sealants to prevent the transfer of water between compartments. The device comes pre-assembled, so we would package the device in a similar manner to a conventional microwave.

### 3.5.5 Timing

One timing constraint we might have is solidifying a production schedule. Finding manufacturers for a relatively novel device will be more difficult than for an existing product like a new microwave.

### 3.5.6 Economic

A better marketing analysis will have to be conducted after making the modifications to the design. Our initial market analysis was most likely too optimistic to use with an upgraded model. Once we modify the design to conduct a more thorough wash cycle and potentially wash the back of the pan, the cost of the product will most likely fall outside of our initial intended range. This will undoubtedly decrease our market size but will also increase ease of distribution and solidify a more loyal customer base.

### 3.5.7 Ergonomic

The Cybernetic design of the device is something that we did not have to deal with too heavily within the initial prototype but would be a key factor in making the product appear to be more technologically

sound. In a final design we might attempt to add a display for the user or increase the number of features that the device can handle. Instructions could be displayed for the user on the screen to increase ease of use.

#### 3.5.8 Ecological

The device has no sustainability impacts that are out of the ordinary. With the proper design and water distribution system modifications this device could potentially use less water than the average person does while washing a pan. This would have a positive sustainability impact by decreasing household water usage.

#### 3.5.9 Aesthetic

Our device would be used by wealthier consumers, so aesthetically the device should look very modern, with a finish that would fit well into an upscale kitchen. This would restrict us to light metals when constructing the exterior of the device.

#### 3.5.10 Life Cycle

With regards to operation, the device should be no louder than a conventional dishwasher and will be used mainly in the kitchen. All debris should be contained within the device until the user decides to dispose of it. Maintenance of the device by the user consists of cleaning the wash compartment, refilling the water basin, and cleaning the brush. With proper rinsing the brush will have to be cleaned once every few cycles and can be dish washed. The wash compartment should theoretically not have to be cleaned as often due to the efficacy of an improved rinse cycle. The water basin must be refilled every two cycles.

#### 3.5.11 Legal

Because our device deals with food and sanitation we will definitely have to deal with FDA approval. Our device must adhere to a similar standard of cleanliness as a dishwasher in order for it to be marketable.

### 4 EMBODIMENT AND FABRICATION PLAN

#### 4.1 EMBODIMENT DRAWING

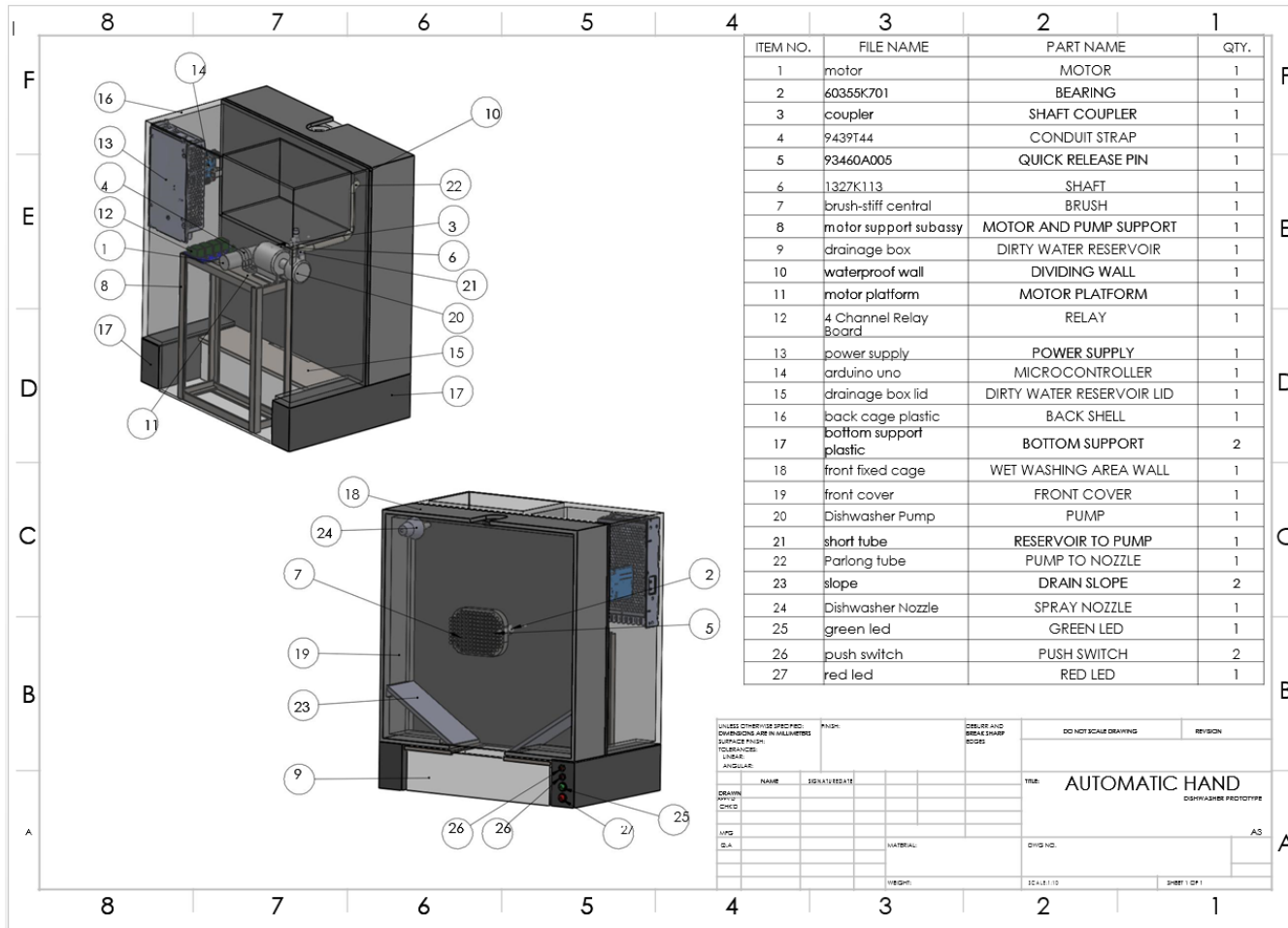

Figure 9 Initial embodiment proposal

## 4.2 PARTS LIST

Our initial proposed list of parts is shown in Table 2 Preliminary Parts List. Our final, full list of parts, in the cost accounting workbook, is provided in Appendix B – Parts List.

**Table 2 Preliminary Parts List**

	<i>Part</i>	<i>Source Link</i>	<i>Supplier Part Number</i>	<i>Color, TPI, other part IDs</i>	<i>Unit price</i>	<i>Tax (\$0.00 if tax exemption applied)</i>	<i>Shipping</i>	<i>Quantity</i>	<i>Total price</i>
<b>1</b>	High Torque Gear Box Electric Mini Motor	<a href="#">Ebay</a>	390545491107	12V DC 60 RPM	\$9.99	\$0.00	\$0.00	1	\$9.99
<b>2</b>	Stainless Steel Two Hole Rigid Conduit Strap	<a href="#">Garvin Industries</a>	THSSR-100	1" diameter	\$2.99	\$0.00	\$8.76	1	\$11.75
<b>3</b>	Shaft Coupler	<a href="#">Sparkfun</a>	ROB-12493	1/4" to 4mm	\$4.99	\$0.00	\$4.60	1	\$9.59
<b>4</b>	Rotary Shaft	<a href="#">McMaster Carr</a>	1327K113	12L14 carbon steel, 1/4" diameter, 3" long	\$3.44	\$0.00	\$10.00	1	\$13.44
<b>5</b>	Double Sealed Ball Bearing	<a href="#">McMaster Carr</a>	60355K701	1/4" shaft diameter, 5/8" OD	\$6.56	\$0.00	\$0.00	1	\$6.56
<b>6</b>	Add-A-Knob Quick Release Pin	<a href="#">McMaster Carr</a>	93460A005	3/16" diameter, 1/2" usable length, #10-32 thread	\$1.87	\$0.00	\$0.00	1	\$1.87
<b>7</b>	Sterilite Small Clip Box	<a href="#">Amazon</a>	B00MVDCW46	11x2.5x6.5 inches	\$8.59	\$0.00	\$0.00	1	\$8.59
<b>8</b>	Steel Thumb Screw	<a href="#">McMaster Carr</a>	90181A636	3/8"-16 thread, 3" long	\$8.78	\$0.00	\$0.00	1	\$8.78
<b>9</b>	Miniature Dispensing Pump	<a href="#">McMaster Carr</a>	8220K43	.61 gpm max flow, 12V DC	\$74.69	\$0.00	\$0.00	1	\$74.69
<b>10</b>	Santoprene Tube	<a href="#">Sharptek Supply</a>	114202	3/16" ID, 3/8" OD, 8 1/4" long	\$5.01	\$0.00	\$10.49	1	\$15.50

11	Coolant Hose Connector	<a href="#">McMaster Carr</a>	10095K31	1/4" ID	\$4.35	\$0.00	\$0.00	1	\$4.35
12	Coolant Hose Assembly with Nozzle	<a href="#">McMaster Carr</a>	10095K11	1/4" ID	\$8.75	\$0.00	\$0.00	1	\$8.75
13	LED light	<a href="#">Digi-Key</a>	5590202007F	Green, 5V, 12mA	\$2.41	\$0.00	\$11.79	1	\$14.20
14	LED light	<a href="#">Digi-Key</a>	5590102007F	Red, 5V, 12mA	\$2.41	\$0.00	\$0.00	1	\$2.41
15	Power Supply	<a href="#">Digi-Key</a>	PMT-D1V100W1AA	AC DC converter, 12V, 5V output	\$32.22	\$0.00	\$0.00	1	\$32.22
16	Sainsmart 4-Channel Relay Module	<a href="#">Amazon</a>	B0057OC5O8	5V 4-Channel	\$8.79	\$0.00	\$0.00	1	\$8.79
17	Pushbutton	<a href="#">Digi-Key</a>	30-601 BLK	Grey	\$2.77	\$0.00	\$0.00	1	\$2.77
18	RedBoard - Programmed with Arduino	<a href="#">Sparkfun</a>	DEV-12757	7-15V input, 0-5V output	\$19.95	\$0.00	\$0.00	1	\$19.95
19	Acrylic Sheet	<a href="#">Home Depot</a>	241929	18" x 24" x .22"	\$20.97	\$0.00	\$0.00	3	\$62.91
20	Carbon Steel	<a href="#">McMaster Carr</a>	9017K124	90 Degree Angle, 9 ft	\$18.51	\$0.00	\$0.00	1	\$18.51
<b>Total:</b>									\$335.62

### 4.3 DRAFT DETAILED DRAWINGS FOR EACH MANUFACTURED PART

The CAD drawings for each part we manufactured are provided in Appendix D – CAD models.

### 4.4 DESCRIPTION OF THE DESIGN RATIONALE FOR THE CHOICE/SIZE/SHAPE OF EACH PART

1. [High Torque Gear Box Electric Mini Motor](#)

The brush must spin with a high torque so that it can effectively “scrub” the pan, but does not have to rotate at a high speed - we determined that between 60 and 100 RPM would be sufficient. This motor had the highest torque of any we found, at 11.5 lb-ft, and operates at 60RPM. It is also 12V DC which is appropriate for our prototype.

2. [Shaft Coupler](#)

The motor selected has metric dimensions with a 4mm shaft, so this coupler was chosen because it has a 4mm side and a 1/4” side, so it can be coupled with an Imperial shaft.

3. [Rotary Shaft](#)

This shaft was selected because it fits one side of the coupling. The shortest length possible was chosen, and we will machine it down to the correct length required so that it will fit between the motor and the brush within the housing.

4. [Double Sealed Ball Bearing](#)

A watertight seal between the wet area and the dry area is required, so that water from the spraying does not reach the electronic components. A sealed ball bearing with the correct inner diameter for the rotary shaft was selected, and will be force fit into the separating partition.

5. [Add-A-Knob Quick Release Pin](#)

Our design requires that the user remove the brush head after each wash, so that they can wash it inside a normal dishwasher to remove any food debris remaining. The brush therefore must be simple, quick, and easy to uninstall and reinstall. A quick release pin allows for a secure connection, but the consumer can easily disconnect the brush without requiring any extra tools. This particular pin is threaded, and can be connected to the brush with a threaded hole.

6. [Sterilite Small Clip Box](#)

A shallow bin is required for the dirty water collection, so that the height of the device can be minimized. However, a box which is too shallow would allow water to splash back up and potentially onto the counter. We will also minimize splashing by modifying the lid so that the dishwasher drains into a smaller hole. Ultimately, we did not purchase this part, we used a container we already owned.

7. [Steel Thumb Screws](#)

The screws must be tightened by the user, so must need to be comfortable enough to grip and hand-tighten. They also must extend enough to reach the edges of the pan, and these screws are long enough at 3”.

8. [Santoprene Tube](#)

This tube will fit onto the pump, which requires a tube with inner diameter of 3/16”. It will connect the pump to the hose assembly.

9. [Hose Connector](#)

This hose connector fits the diameter of the above-mentioned tube, so that the tube can be connected to the rest of the nozzle assembly.

10. [Hose Assembly with Nozzle](#)

The nozzle allows the water to spray over the dirty pan. It is also bendable to allow for redirection if the angle is incorrect as we run testing.

11. [LED light \(red and green\)](#)

Lights are desired to indicate the status of the washing cycle, so that the user will know when they are able to take the pan out without having to listen for the motor or spray. Two different colored lights will differentiate whether or not the pan is being washed.



12. [Power Supply](#)  
A power supply is required for the Arduino, brush motor, and water pump. This particular supply has outputs of 5V and 12V. The Arduino runs at 5V and the motor and pump at 12V, so this an appropriate supply. It is also 100W power supply which will be sufficient for approximately 25W pump.
13. [Sainsmart 4-Channel Relay Module](#)  
This relay module is necessary to allow the Arduino to turn the motor and pump on and off, since they are at a higher voltage than the Arduino.
14. [Pushbutton](#)  
A way for the user to manually start the cycle is desired.
15. [RedBoard - Programmed with Arduino](#)  
An Arduino is needed to program the motor and pump timing, so that the cycles for scrubbing and rinsing can be set and run automatically with no user input.
16. [Acrylic Sheeting](#)  
We chose to work with acrylic sheeting for our housing, rather than sheet metal. This is because it is easier to work with, and will also allow us to observe the dishwasher processes as it is operating.
17. [Metal Stock](#)  
We want to raise the motor up so that it is directly aligned with the brush shaft. The stock selected is strong and will create a secure platform.



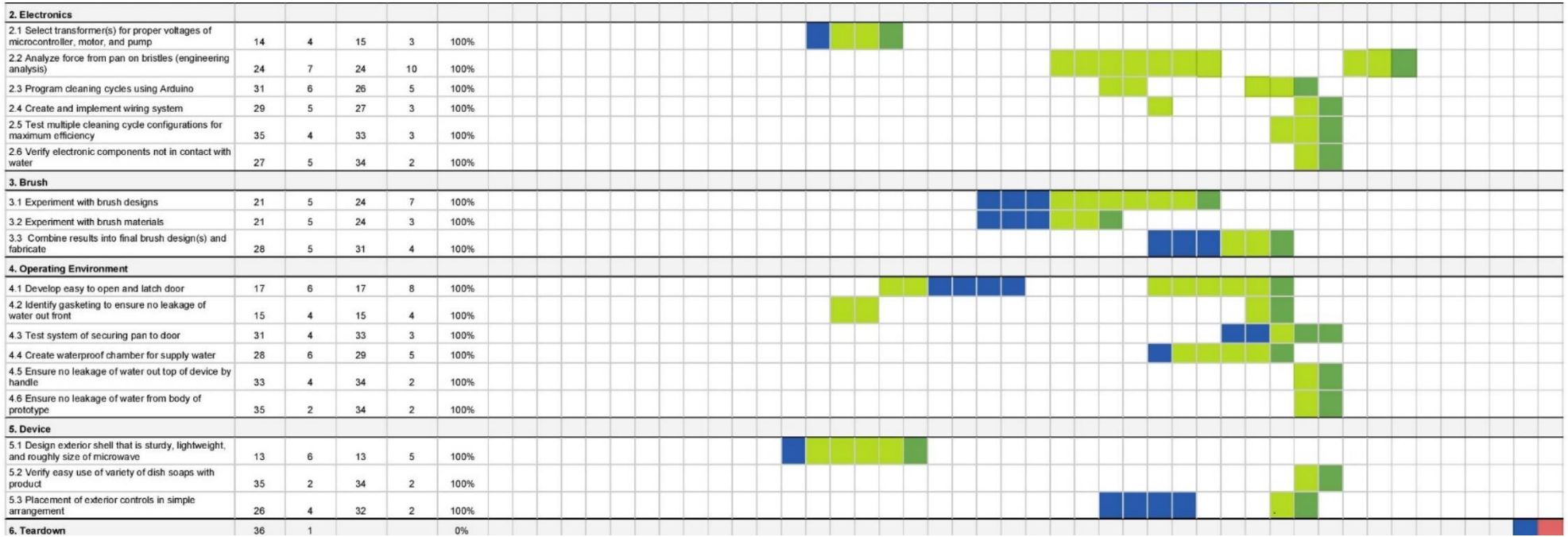

Figure 11 Gantt Chart Part 2

## 5 ENGINEERING ANALYSIS

### 5.1 ENGINEERING ANALYSIS RESULTS

A full SolidWorks report is provided in Appendix E – SolidWorks Report.

#### 5.1.1 Motivation

- a. Our largest issue with the prototype was the design of the rotating scrubbing brush. We altered the design multiple times along the way as we realized the materials did not behave in the manner we were expecting. Our ideal brush design is a straight brush flexible enough to work for pans of different depths and diameters. The material we worked with was steel sheeting, which was flexible but remained bent in shape. We were unable to find a material given our time constraints that could bend properly to engage the entire surface and lips of differently sized pans. We ended up molding the brush to fit our test pans and added the ability to alter the radius of the brush, which we believe is not ideal for user convenience. With our analysis, we hoped to determine a better idea of what material we would look for in an end-stage prototype with a commercially viable brush. While torque applied from rotation is also of interest to us, our main concern was the force applied to the backing from the static pressure of the pan. Additionally, we at first intended to have a much more sophisticated analysis modeling the bristles and contact of the pan, but after many hours of failed tests and consultations with classmates more experienced with SolidWorks Simulation we were advised to greatly simplify our simulations.
- b. As we struggled to find an effective design for the brush, this would be one of our main focuses to optimize if we were able to do a second iteration within the scope of a semester. Since everything else in the prototype was proven to work comparably well, more time and money could be budgeted to design a brush that performs as we had initially desired with less adjusting by the user.

#### 5.1.2 Summary Statement of Analysis Done

- a. A SolidWorks simulation was run, as shown in Figure 12, modeling an applied force to the metal backing transmitted through the bristles. The force was designed to approximate the force applied by the pan to the brush backing. After finding an optimal elastic modulus of the backing sheet, the deflection appeared as it does in Figure 12.

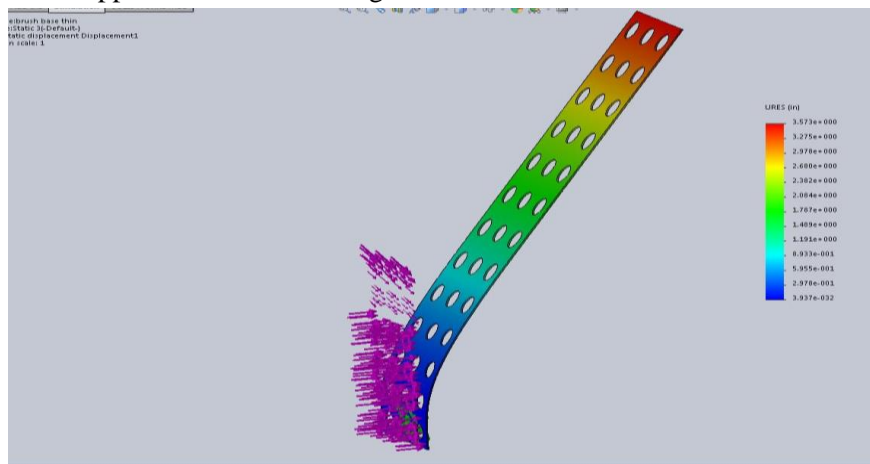
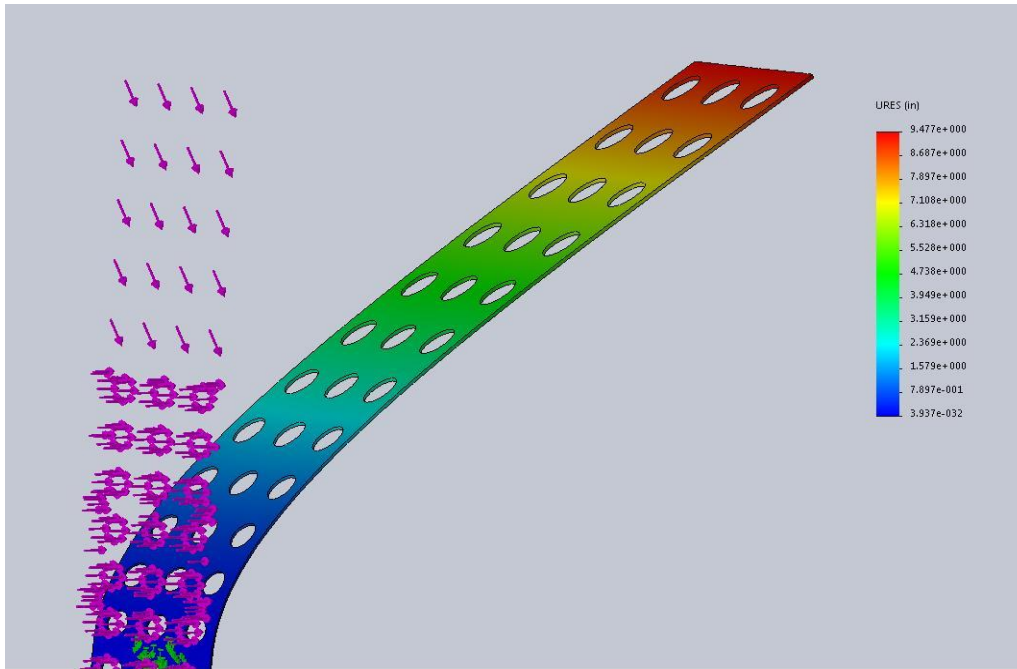

Figure 12 Simulation of applied force on brush backing, 6" diameter pan

However, after changing the force applied to mimic that of a large radius pan, our deformation pattern appeared as it does in Figure 13.

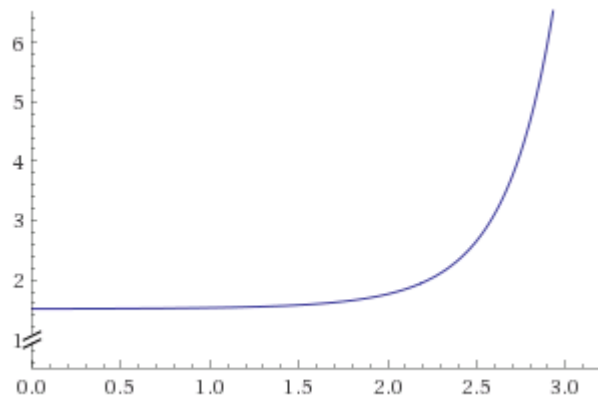

**Figure 13 Simulation of applied force on brush backing, 14" diameter pan**

Clearly this deformation is not what we desire since the bristles will end up a significant distance from the pan surface. Commentary on these results is provided in the following sections.

### 5.1.3 Methodology

- a. This force was first modeled as a total of approximately ten pounds of total force applied to the brush in the first 3.25 inches of its radius. This simulates a roughly 6-inch radius pan. The first two inches of the brush received a pound and a half of force, while the region from 2 inches to 3.25 inches received a distributed force angled at a 45° angle towards the shaft described as  $0.01\exp(x1.7)+1.5$  where  $x=0$  is the base of the brush at the axis of rotation. This means that the force distribution on the backing appeared as it does in Figure 14.



**Figure 14 Visualization of applied force on brush from pan**

The shape of the applied force approximates the shape of the lip of the pan. The point of rotation for the brush was set to be fixed. The material elastic modulus was modified to find properties that would best suit our desired deformation in this case. In the second case, the force was prescribed as 0.5 lbs for the first 4 inches, then modeled as  $0.01\exp((x-3)^{1.7})+0.5$  for the next 3 inches, angled at a 45° angle towards the shaft as with the 6" pan. This simulated a 7 inch radius pan with an approximate total of 10 lbs of force applied. All other constraints and material properties were unchanged.

- b. The value of the elastic modulus of material was experimented with, but no physical experiments were done as we did not have easy access to the types of materials we were considering. The geometry of the brush was designed to be identical to our working prototype.
- c. While torque applied from rotation is of interest to us, our main concern was the force applied to the backing from the static pressure of the pan. Additionally, we at first intended to have a much more sophisticated analysis modeling the bristles and contact of the pan, but after many hours of failed tests and consultations with classmates more experienced with Solidworks Simulation we were advised to greatly simplify our simulations.
- d. No test rig was required.

#### 5.1.4 Results

- a. Our study reveals something that should have been more obvious to us from the beginning of designing our brush, which is that a simple, uniform shape of uniform properties cannot bend to match the behavior necessary to maintain contact with the pan. While a brush may be designed that accommodates one size of pan adequately, it is likely impossible to design a brush of constant cross-sectional area and properties which can flex to contact a range of pan diameters. This explains the wild results of our second simulation, where the brush is dramatically bent and would make almost no contact with the pan. The ideal elastic modulus for the 6 inch diameter case was found to be 50 GPa, which could be true of many flexible metals.
- b. These results can be imagined as a beam in bending that is fixed at one end. While the load is distributed over the length of the beam, it is concentrated at the edge of the pan. The brush bends most significantly, under the most stress, near the point of fixture. However, this removes contact from the bristles to the pan along the flat region of the pan. Ideally, we wished for the brush beam to remain straight until the pan lip began to impart a large force on the beam. This is simply not to be expected with a uniform beam.
- c. New brush concepts would likely feature non-uniform cross sectional area or material properties, so that the stiffness of the brush is much greater near the center of the pan. The brush might be thicker near the center and gradually decrease in thickness as it reached the tip, so it would bend less easily near the base but easier in regions where the pan lip applied a force. A possibility of how this could be designed is shown in the drawings section of our Engineering Analysis.

#### 5.1.5 Significance

- a. Because the material options and manufacturing time are outside of the resources we have remaining for this class, it is not feasible for us to physically create a brush based on our analysis results. However, we can modify our engineering drawings to reflect a more ideal brush design.
- b. Obviously, the results of our simulation change our material choice for the brush backing since that is what we are modifying to achieve our desired results. The dimensions of our model may

also change slightly so that the brush behaves more as desired – for example, a narrower backing results in more flexibility, as does a thinner sheet of material.

- c. Our prototype brush design is shown in Figure 15.

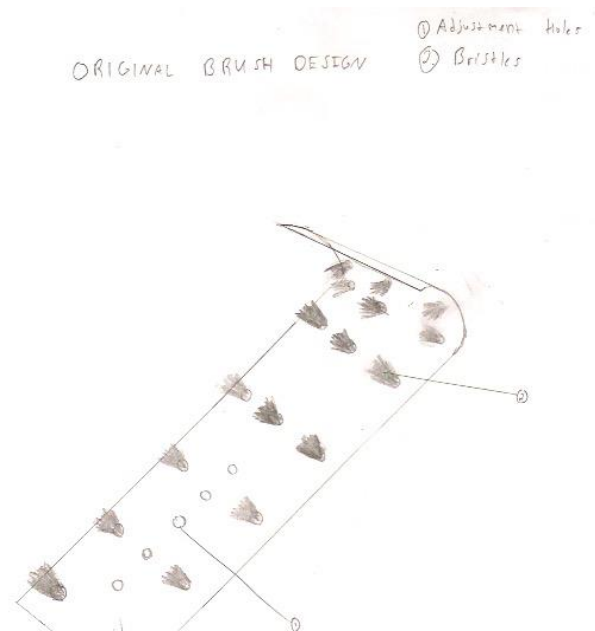

**Figure 15 Existing prototype brush design**

The new brush design with the modifications from our analysis is shown in Figure 16 and Figure 17.

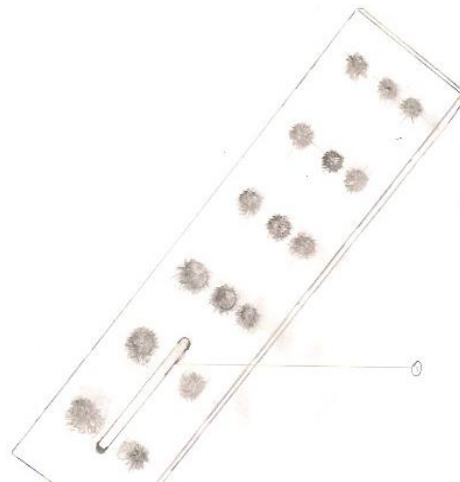

**Figure 16 Proposed brush design modifications from analysis results – isometric view**

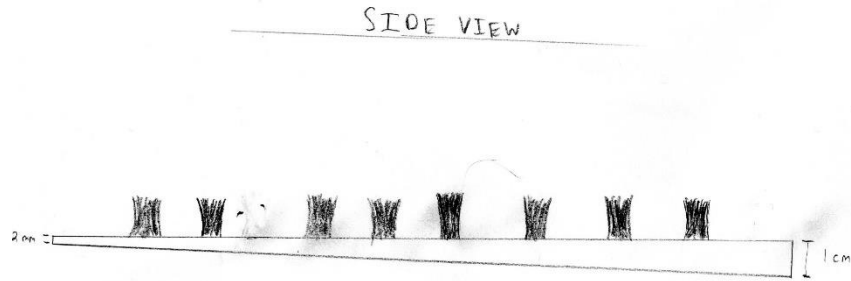

Figure 17 Proposed brush design modifications from analysis results - side view

5.1.6 Summary of Code and Standards and their Influence

The NSF/ANSI Standard 184 for residential dishwashers restricts the use of any material with arsenic, cadmium, lead, or mercury, which is not a concern as these are not materials we would consider for any part of the design. In addition, “interior surfaces repeated exposed to wash water, rinse water, or both, are not required to be smooth,” which allows for any type of texture to be used for the brush since it will be in contact with water. Finally, exposed surfaces must be corrosion resistant or can be coated to create a corrosion resistant surface, which allows us to use the material resulting from our analysis.

5.2 RISK ASSESSMENT

5.2.1 Risk Identification

Our analyzation of the various risks to our project is shown in a heat map in Figure 18.

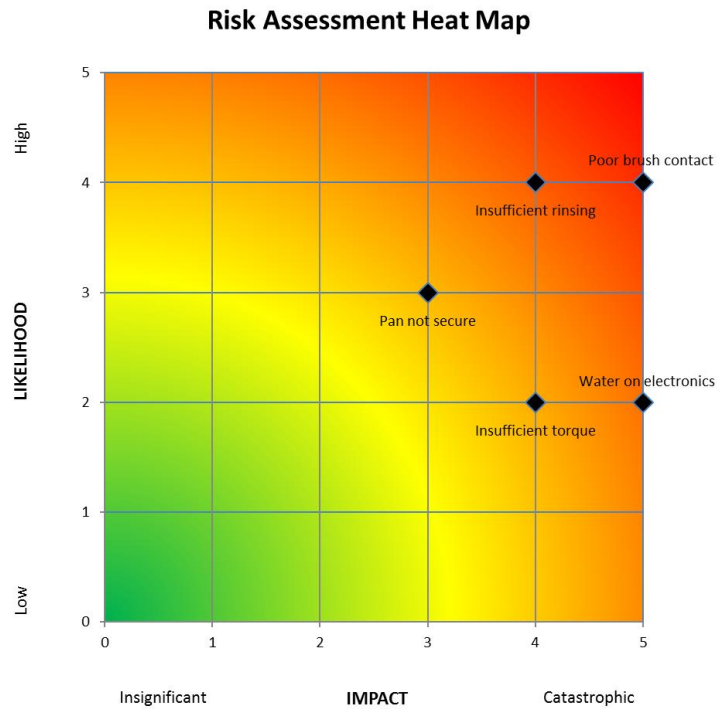

Figure 18 Risk Assessment Heat Map



### 5.2.2 Risk Impact or Consequence Assessment

1. Insufficient rinsing: Since the pan is meant to be completely clean when it comes out of the machine, if it were not sufficiently rinsed – either soap or food particles remained – it would be viewed as a failure to perform to its design metrics. It is not a completely catastrophic risk, since if the particles are not stuck, the user could give the pan a quick rinse under the faucet. But this would severely impact the overall performance rating of the device, since we were intending to avoid that additional hassle in the first place. Our testing has shown that the nozzles do not reach every point of the pan and this sometimes leaves a soapy residue, so this risk is medium high.
2. Poor brush contact: This was the issue we had to troubleshoot the most, so its likelihood is medium high. We achieved the best results by slightly altering the brush shape until it worked best. This issue has a catastrophic impact on performance, since if the brush isn't able to scrub away debris, the spraying water is much less likely to rinse it clean.
3. Water on electronics: The impact of this would be catastrophic, as the entire operation depends on the automatic cycling of rinsing and scrubbing. However, we were careful in designing and building to protect the electronics and separate the “wet” and “dry” side, with tight fitting bearings and waterproof caulking, so the likelihood of water contact is low-medium, as long as the prototype is handled carefully.
4. Pan not secure: This was a problem we occasionally encountered when running tests, so the likelihood is medium. However, it was easily fixed by adjusting the pan, and the process would be improved in future prototypes, so the impact is moderate.
5. Insufficient torque: The motor we selected is rated to a torque of 11.5 lb-in. We were hoping to perform an engineering analysis to calculate how much force would be applied to the pan without restricting the turning, which turned out to be infeasible to complete within our timeline. Had our motor not performed well, it would have had a significant impact. However, in our testing it did not appear to be an issue, so the likelihood is low-medium.

### 5.2.3 Risk Prioritization

1. Water on electronics (most critical)
2. Poor brush contact
3. Insufficient rinsing
4. Pan not secure
5. Insufficient torque (least critical)

## 6 WORKING PROTOTYPE

### 6.1 FINAL DEMONSTRATION OF THE WORKING PROTOTYPE

#### [Final Working Prototype Demonstration](#)

## 6.2 PHOTOGRAPHS OF PROTOTYPE

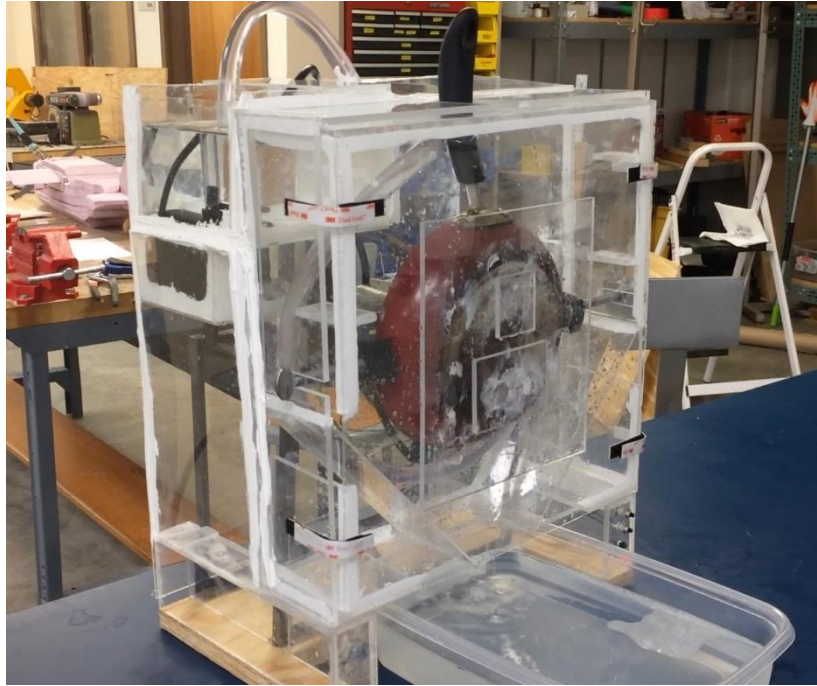

Figure 19 Pan (approximately 8" diameter) loaded into prototype

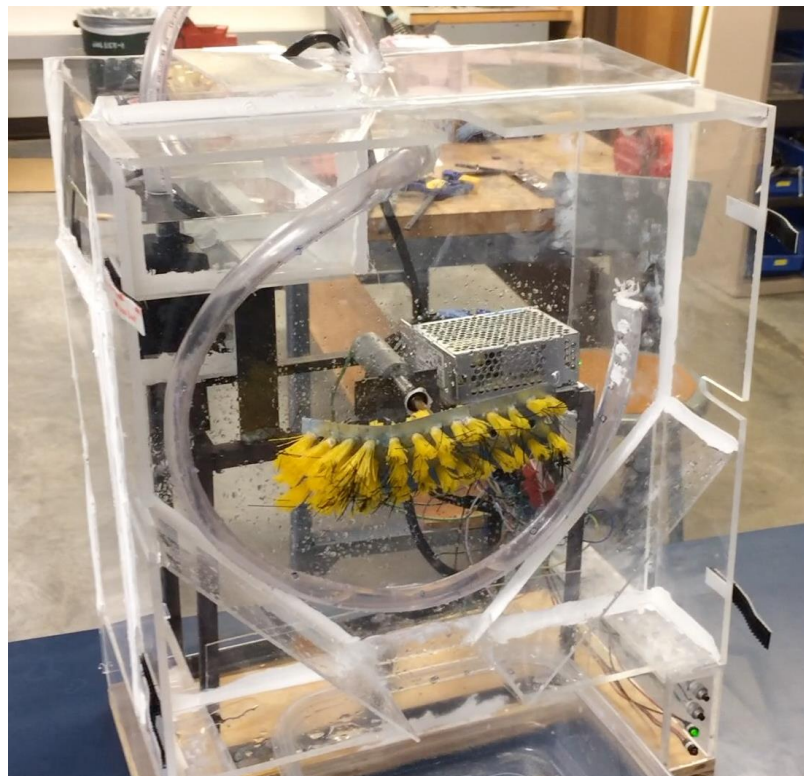

Figure 20 Washing area showing nozzle setup and brush

## 6.3 VIDEO OF PROTOTYPE

[Demonstration of Single Dishwasher Cycle](#)

### 6.4 ADDITIONAL PHOTOGRAPHS AND EXPLANATIONS



Figure 21 Power supply for pump, motor, and Arduino



Figure 22 Mechanism for keeping pan secured

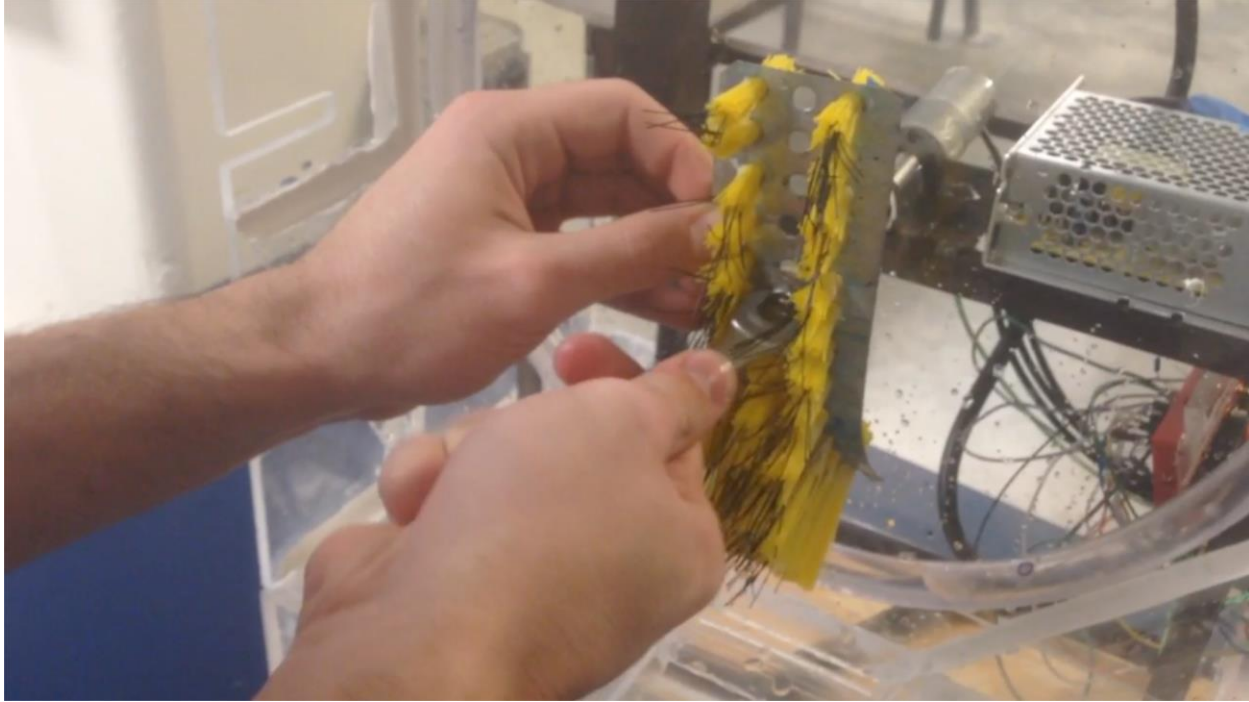

Figure 23 Changing brush to accommodate pans of different diameters

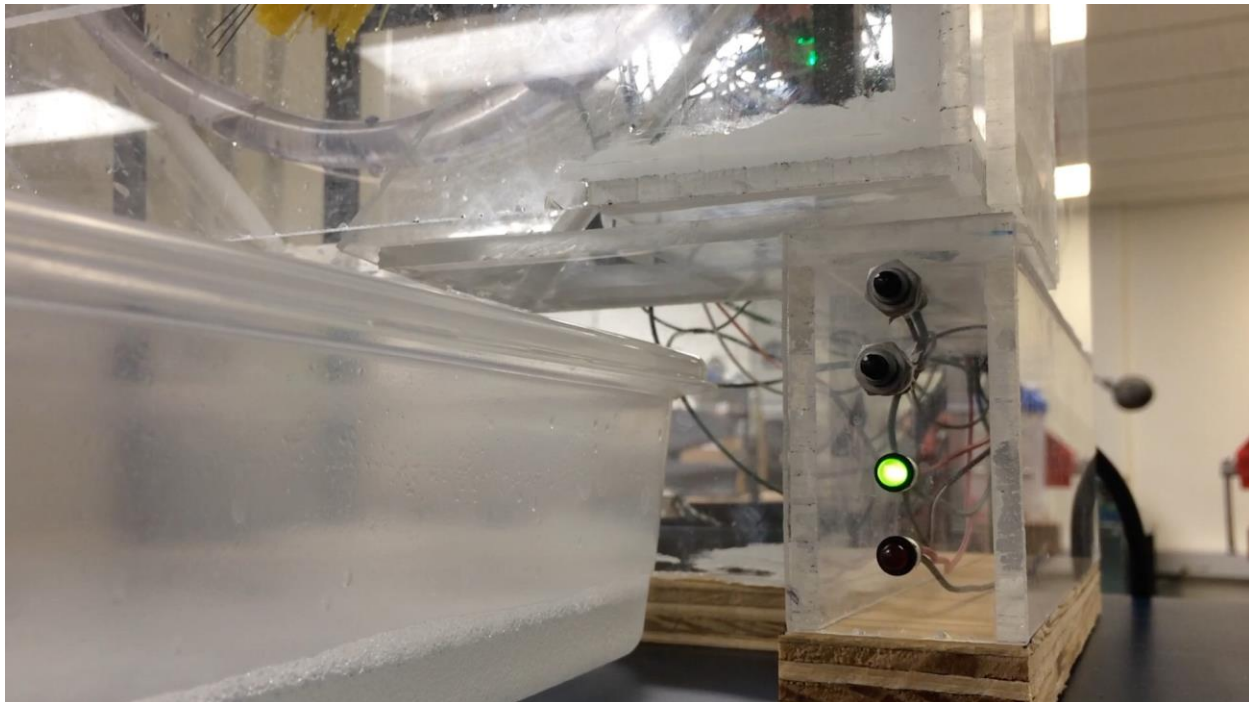
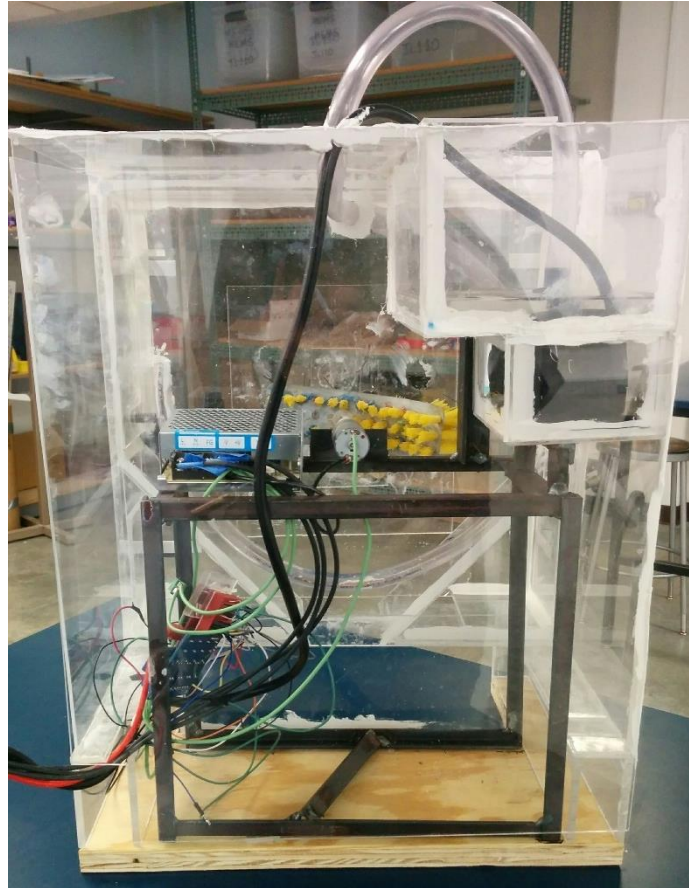

Figure 24 Top button runs a single cycle, with red indicating cycle in process and green indicating cycle is done. Bottom button runs only pump until the top button is pressed to turn it off.



**Figure 25** Back view showing motor platform and submersible pump in chamber

## 7 DESIGN DOCUMENTATION

### 7.1 FINAL DRAWINGS AND DOCUMENTATION

#### 7.1.1 Engineering Drawings

See Appendix D – CAD models of Fabricated Parts for engineering drawings.

#### 7.1.2 Sourcing Instructions

The full list of parts provided in Appendix B – Parts List must be purchased, with the exception of the peristaltic pump which had too low of a flow rate. In addition to the purchased parts, we were able to find used parts inside the machine shop to use at no cost. These parts were a wooden base, wires, and more super glue, which could be purchased as well. To program the Sparkfun Redboard, one would need to know how to write Arduino code and have the Arduino software on their computer in order to program the cycle. The code for our project is provided in Appendix F – Arduino Code.

### 7.2 FINAL PRESENTATION

#### 7.2.1 Presentation

[Slides Presented to Engineering Review Board](#)

7.2.2 [Link to Project Video](#)  
[Video Summary of Project](#)

### 7.3 TEARDOWN

#### TEARDOWN TASKS AGREEMENT

PROJECT: Panwasher NAMES: Carter Fournier INSTRUCTOR: JAKIELA  
Aaron Walker Mrs. J. J. J. J.  
Caryn Davidson

The following teardown/cleanup tasks will be performed:

clean up storage shelf  
 put away tools

Figure 26 Teardown Agreement with Professor Jakiela

Instructor comments on completion of teardown/cleanup tasks:

Instructor signature: Mary Malast Print instructor name: MARY MALAST  
 Date: 12/8/16

(Group members should initial near their name above.)

Carter Fournier  
Aaron Walker  
Caryn Davidson

Figure 27 Teardown Agreement with Professor Malast

## 8 DISCUSSION

### 8.1 HOW WELL WERE THE NEEDS MET IN THE FINAL PROTOTYPE?

Our final prototype successfully met all our initial design metrics. The device successfully cleaned multiple sizes of a non-stick pan, from 6" to 14" in diameter, in under a minute, when tested with cooking oil and vegetable pieces. Our price tag goal was \$300, which our budget did exceed, but only due to

iterations of certain design aspects. The device can be placed in any kitchen with the countertop space for a 2 cubic feet appliance, and requires no specialized installation from the customer or a technician.

## 8.2 DISCUSS ANY SIGNIFICANT PARTS SOURCING ISSUES – DELIVERY TIME, SCROUNGING?

With delivery times in mind, we ordered the online parts early, such as the motor and power supply, so wait was not an issue. Most of our other parts were purchased in-store at Home Depot. We did run into an issue with our first peristaltic pump performing poorly, but it was quickly solved by purchasing an aquarium pump at PetCo. We also scrounged for a small number of parts, but only for budget reasons – they could easily be purchased as well.

## 8.3 DISCUSS THE OVERALL EXPERIENCE

### 8.3.1 Was the project more or less difficult than you had expected?

Overall we did not encounter any insurmountable technical or conceptual challenges. We were often surprised by the amount of time required to complete tasks required to the project. However, we believe the long hours contributed to this project show in our results and prototype. Many of the most significant challenges we had to work through came up during the embodiment and fabrication phase of the project as we were trying to clean up loose ends related to how our design would come together. Many of our idea were initially not well thought out and took time to make feasible. It was sometimes difficult to find solutions that were sophisticated enough to meet our design requirements but simple enough to implement within our short timeframe.

### 8.3.2 Does the final project align with the project description?

Our final prototype meets all of the goals set out in our initial proposed project statement except we constrained our pan materials to non-stick Teflon. This decision was made after our market research suggested this was the most popular material for consumer pans. At one time, early in the semester, we considered including pots and cookware made of cast iron in our project scope, but this was very quickly cut out.

### 8.3.3 Did your team function well as a group?

Our team was able to communicate well through a variety of outlets. We were always very honest with each other and were able to work through ideas quickly, both in praise and criticism, by always being willing to share our full opinions without reservation. We feel as though we were able to thoroughly vet poor ideas and select better ideas to pursue due to this continued frankness.

### 8.3.4 Were your team members' skills complementary?

We were able to focus on different aspects of the project depending on our backgrounds and skills. Some members were only experienced with certain design and fabrication techniques, but others had more skills coordinating and organizing information. We tried to play to each other's strengths as best we could.

### 8.3.5 Did your team share the workload equally?

We were able to use tools like the Gantt chart and pre-planning work distributions to split up work assignments fairly and manageably.

### 8.3.6 Was any needed skill missing from the group?

We struggled greatly with the simulations for the engineering analysis. Outside of the lab component of MEMS 3110 Machine Elements, no one in our group had any experience with FEA simulation in Solidworks. Our simulation was more simplistic than we would have liked, however we struggled to make our model perform when designed more sophisticatedly. We consulted with classmates not in our group to help perform our simulations in some cases.

### 8.3.7 Did you have to consult with your customer during the process, or did you work to the original design brief?

We primarily referred back to our market research when deciding how to come up with design goals and when deciding which design metrics were most essential. Our market research reflected the wants of a variety of potential customers representative of the market at large.

### 8.3.8 Did the design brief (as provided by the customer) seem to change during the process?

We did not conduct additional surveys throughout the project. However, advice from course instructors did influence decisions made in fulfilling the requirements of the project. Some simplifications to our prototype were made at the suggestion of course instructors (such as having a removable front door and constructing the frame out of acrylic sheets instead of sheet metal).

### 8.3.9 Has the project enhanced your design skills?

The project allowed us to see the design process from beginning to end. We learned valuable skills on how to take design requirements to design concepts to sketches to CAD files to fabrication. We also gained experience with troubleshooting and problem solving through the prototyping process.

### 8.3.10 Would you now feel more comfortable accepting a design project assignment at a job?

We would be more comfortable accepting a design project assignment, however also perhaps more hesitant understanding the time commitment that it could entail. Despite this, I think we all enjoyed the technical design components of this course the most and would be interested in continuing to participate in similar projects in the workplace.

### 8.3.11 Are there projects that you would attempt now that you would not attempt before?

This project gave us the experience to be able to tackle larger projects involving moving parts, embedded systems, and complex part sourcing. We also gained a better ability to anticipate what challenges might hide in projects that are less obvious. All these skills would enable us to tackle larger, more rigorous projects in our careers and side projects.



9 APPENDIX A – SELECTED MARKET RESEARCH

Age (74 responses)

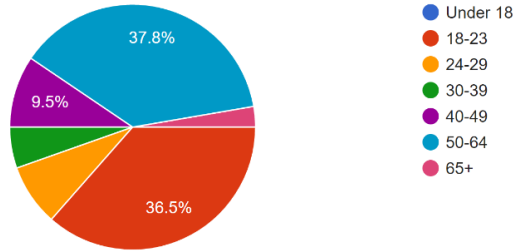

Figure 28 Market Research: Age Results

Living Situation (75 responses)

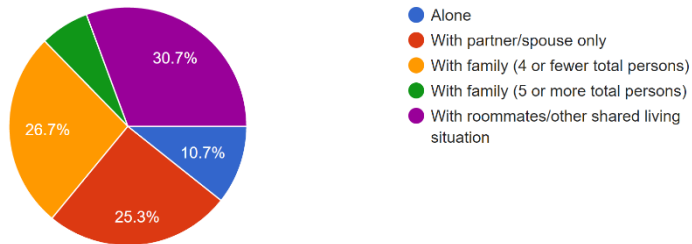

Figure 29 Market Research: Income Results

What size pot or pan do you use the most? (77 responses)

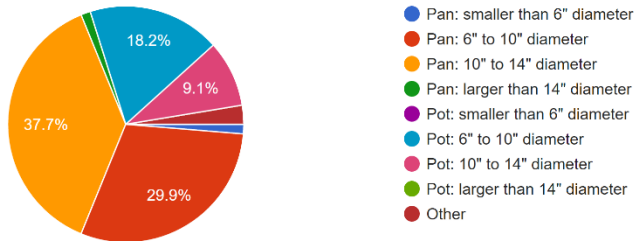

Figure 30 Market Research: Cookware Type

What is this pot/pan made of? (77 responses)

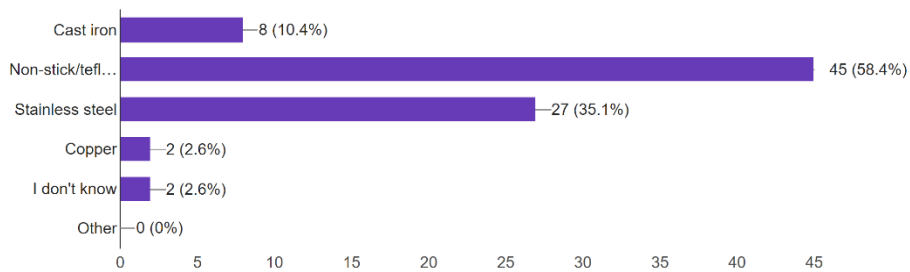

Figure 31 Market Research: Cookware Material

How do you clean it? (76 responses)

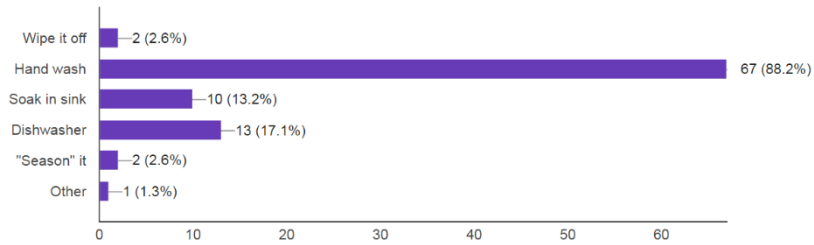

Figure 32 Market Research: Cookware Cleaning Habits

What is the approximate largest size of the device you would be interested in?  
(A typical dishwasher is approximately 12 cubic feet)

(74 responses)

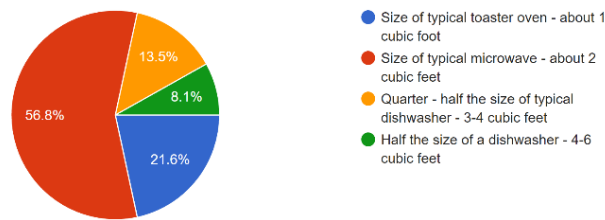

Figure 33 Market Research: Desired Size

Would you still have interest if you had to sometimes clean a removable brush?

(73 responses)

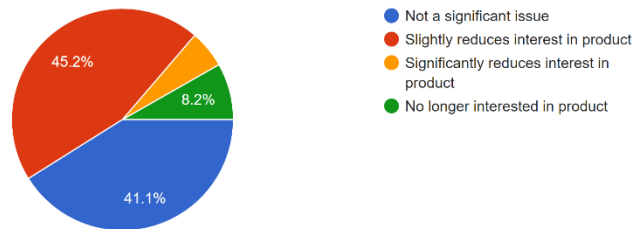

Figure 34 Market Research: Removeable Brush Response

What is your initial interest in this product? (77 responses)

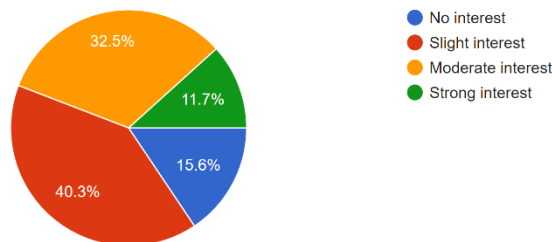

Figure 35 Market Research: Initial Interest

**10 APPENDIX B - PARTS LIST****Table 3 Final Cost Accounting Workbook**

	<i>Part</i>	<i>Source Link</i>	<i>Supplier Part Number</i>	<i>Color, TPI, other part IDs</i>	<i>Unit price</i>	<i>Tax (\$0.00 if tax exemption applied)</i>	<i>Shipping</i>	<i>Quantity</i>	<i>Total price</i>
<b>1</b>	High Torque Gear Box Electric Mini Motor	<a href="#">Ebay</a>	390545491107	12V DC 60 RPM	\$9.99	\$0.00	\$0.00	1	\$9.99
<b>2</b>	Shaft Coupler	<a href="#">Sparkfun</a>	ROB-12493	1/4" to 4mm	\$4.99	\$0.00	\$13.10	1	\$18.09
<b>3</b>	Rotary Shaft	<a href="#">McMaster Carr</a>	1327K113	12L14 carbon steel, 1/4" diameter, 3" long	\$3.44	\$0.00	\$10.00	1	\$13.44
<b>4</b>	Double Sealed Ball Bearing	<a href="#">McMaster Carr</a>	60355K701	1/4" shaft diameter, 5/8" OD	\$6.56	\$0.00	\$0.00	1	\$6.56
<b>5</b>	Add-A-Knob Quick Release Pin	<a href="#">McMaster Carr</a>	93460A005	3/16" diameter, 1/2" usable length, #10-32 thread	\$1.87	\$0.00	\$0.00	1	\$1.87
<b>6</b>	Steel Thumb Screw	<a href="#">McMaster Carr</a>	90181A636	3/8"-16 thread, 3" long, pack of 10	\$8.78	\$0.00	\$0.00	1	\$8.78
<b>7</b>	Peristaltic Liquid Pump	<a href="#">Mouser</a>	485-1150		\$24.95	\$0.00	\$7.99	1	\$32.94
<b>8</b>	LED light	<a href="#">Digi-Key</a>	5590202003F	Green, 5V, 12mA	\$2.41	\$0.00	\$9.45	1	\$11.86
<b>9</b>	LED light	<a href="#">Digi-Key</a>	5590102007F	Red, 5V, 12mA	\$2.41	\$0.00	\$0.00	1	\$2.41
<b>10</b>	Power Supply	<a href="#">Digi-Key</a>	1145-1072-ND	AC DC converter, 12V output	\$16.33	\$0.00	\$0.00	1	\$16.33

<b>11</b>	Sainsmart 4-Channel Relay Module	<a href="#">Amazon</a>	B0057OC5O8	5V 4-Channel	\$8.49	\$0.00	\$0.00	1	\$8.49
<b>12</b>	Pushbutton	<a href="#">Digi-Key</a>	30-601 BLK	Grey	\$2.77	\$0.00	\$0.00	2	\$5.54
<b>13</b>	RedBoard - Programmed with Arduino	<a href="#">Sparkfun</a>	DEV-12757	7-15V input, 0-5V output	\$19.95	\$0.00	\$0.00	1	\$19.95
<b>14</b>	Carbon Steel	<a href="#">McMaster Carr</a>	9017K124	90 Degree Angle, 9 ft	\$18.51	\$0.00	\$0.00	1	\$18.51
<b>15</b>	Barrel Jack	<a href="#">Sparkfun</a>	PRT-10287	Power for Arduino	\$2.95	\$0.00	\$0.00	1	\$2.95
<b>16</b>	Hand and Nail Brush	<a href="#">Home Depot (in-store)</a>	SKU #611533	Scotch-Brite	\$2.99	\$0.29	\$0.00	2	\$6.27
<b>17</b>	Steel Sheet	<a href="#">Home Depot (in-store)</a>	SKU #1001195220	1'x1' Galvanized	\$5.98	\$0.57	\$0.00	1	\$6.55
<b>18</b>	Soft Brush	<a href="#">Home Depot (in-store)</a>	SKU #1000018629	8.5"	\$4.97	\$0.48	\$0.00	1	\$5.45
<b>19</b>	Super glue	<a href="#">Home Depot (in-store)</a>	SKU #612924	Gorilla .7 oz	\$5.97	\$0.57	\$0.00	1	\$6.54
<b>20</b>	Acrylic Sheet (thick)	<a href="#">Home Depot (in-store)</a>	SKU #241929	18" x 24" x .22"	\$20.97	\$2.02	\$0.00	2	\$43.96
<b>21</b>	Acrylic Sheet (thin)	<a href="#">Home Depot (in-store)</a>	SKU #202089	.093"x20"x32"	\$15.73	\$1.51	\$0.00	2	\$32.97
<b>22</b>	Screw Nut	<a href="#">Home Depot (in-store)</a>	SKU #326275	#10-32	\$1.18	\$0.11	\$0.00	1	\$1.29

<b>23</b>	Tube	Home Depot (in-store)	SKU #739236442581	5/80DX1/2IDX20'	\$8.72	\$1.04	\$0.00	1	\$9.76
<b>24</b>	Sealant	Home Depot (in-store)	SKU#079340649118	LOCTITE 10.1 oz	\$12.97	\$1.04	\$0.00	1	\$14.01
<b>25</b>	Submersible pump	PetCo		70 GPH	\$15.99	\$1.54	\$0.00	1	\$17.53
<b>26</b>	Velcro	Home Depot (in-store)	5113164254	1"x3" 4 black strips	\$3.57	\$0.34	\$0.00	1	\$3.91
<b>27</b>	Wood platform	Machine shop			\$0.00	\$0.00	\$0.00	1	\$0.00
<b>Total:</b>									\$325.95

## 11 APPENDIX C – BILL OF MATERIALS

Table 4 Final Bill of Materials

ITEM NO.	FILE NAME	PART NAME	QTY.
1	motor	MOTOR	1
2	60355K701	BEARING	1
3	coupler	SHAFT COUPLER	1
4	9439T44	CONDUIT STRAP	1
5	93460A005	QUICK RELEASE PIN	1
6	1327K113	SHAFT	1
7	brush-stiff central	BRUSH	1
8	motor support subassy	MOTOR AND PUMP SUPPORT	1
9	drainage box	DIRTY WATER RESERVOIR	1
10	waterproof wall	DIVIDING WALL	1
11	motor platform	MOTOR PLATFORM	1
12	4 Channel Relay Board	RELAY	1
13	power supply	POWER SUPPLY	1
14	arduino uno	MICROCONTROLLER	1
15	drainage box lid	DIRTY WATER RESERVOIR LID	1
16	back cage plastic	BACK SHELL	1
17	bottom support plastic	BOTTOM SUPPORT	2
18	front fixed cage	WET WASHING AREA WALL	1
19	front cover	FRONT COVER	1
20	Dishwasher Pump	PUMP	1
21	short tube	RESERVOIR TO PUMP	1
22	Parlong tube	PUMP TO NOZZLE	1
23	slope	DRAIN SLOPE	2
24	Dishwasher Nozzle	SPRAY NOZZLE	1
25	green led	GREEN LED	1
26	push switch	PUSH SWITCH	2
27	red led	RED LED	1

12 APPENDIX D - CAD MODELS OF FABRICATED PARTS

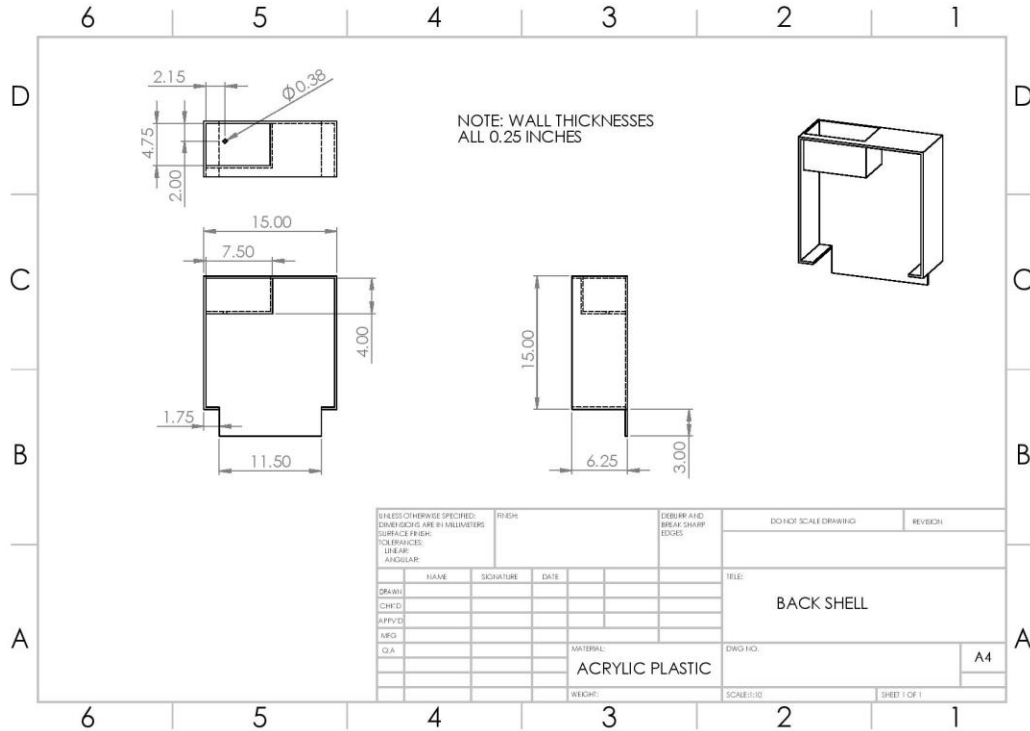

Figure 36 Back Cage

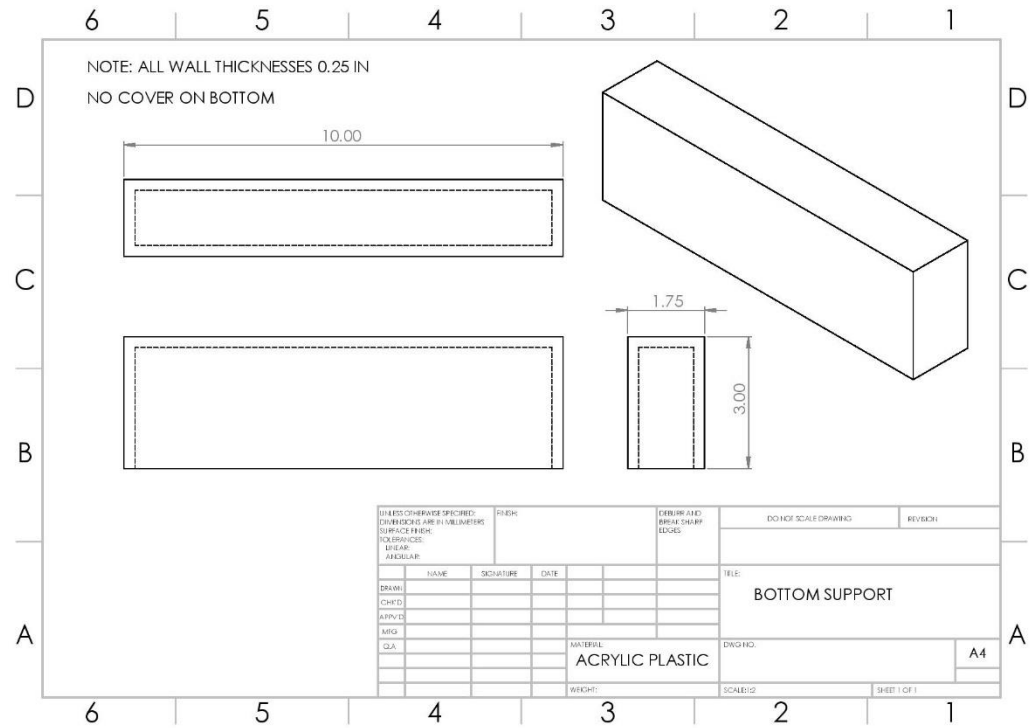

Figure 37 Bottom Support

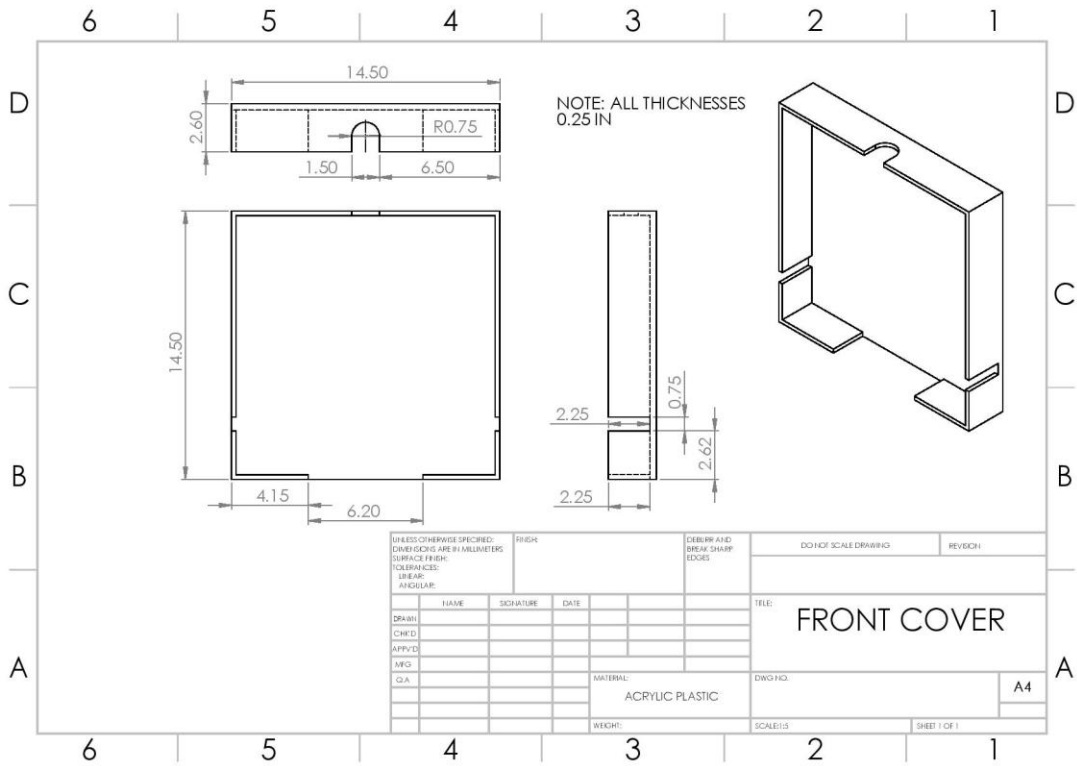

Figure 38 Front Cover

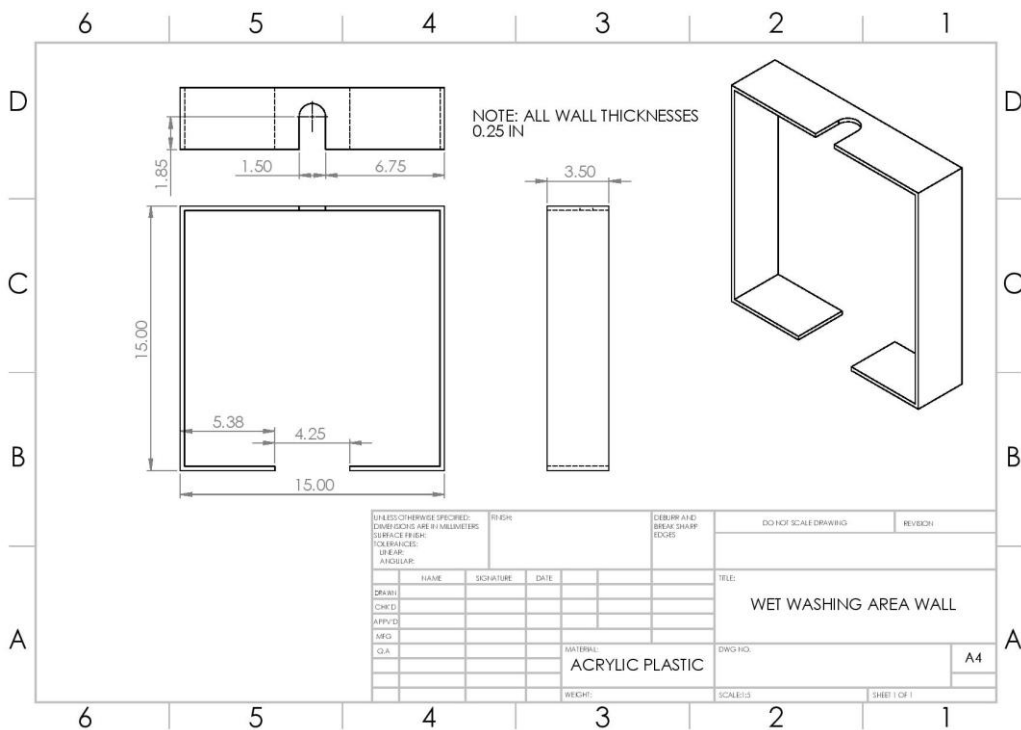

Figure 39 Wet Washing Cage



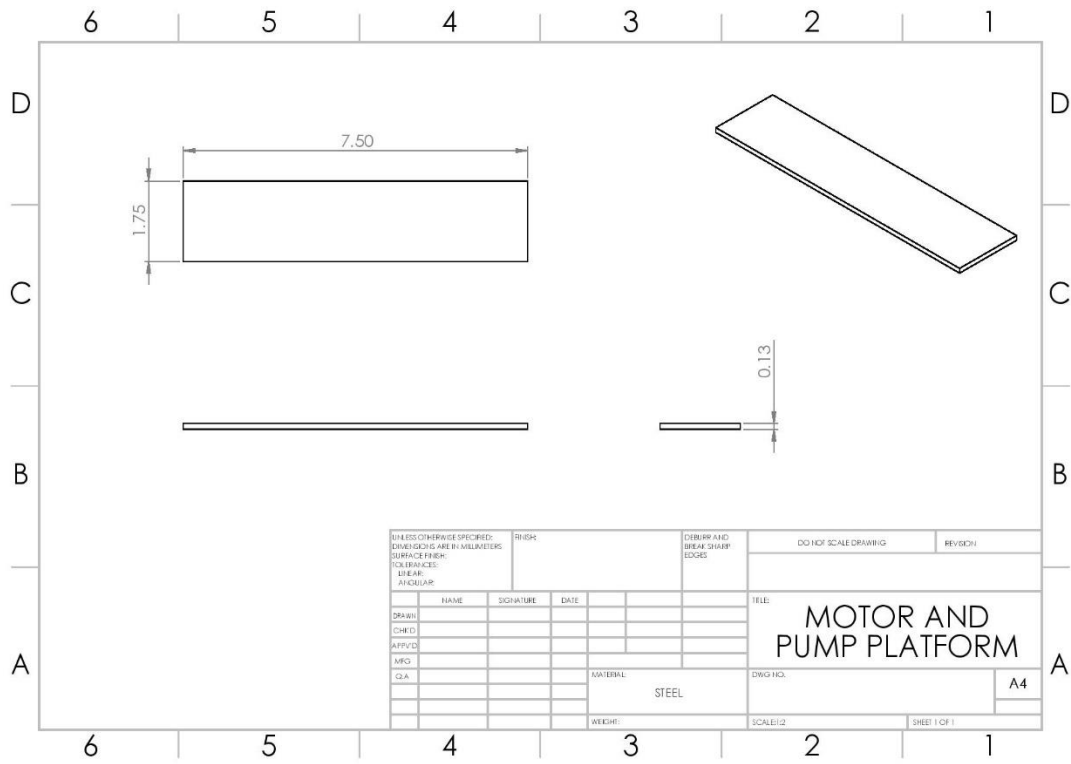

Figure 40 Motor Platform

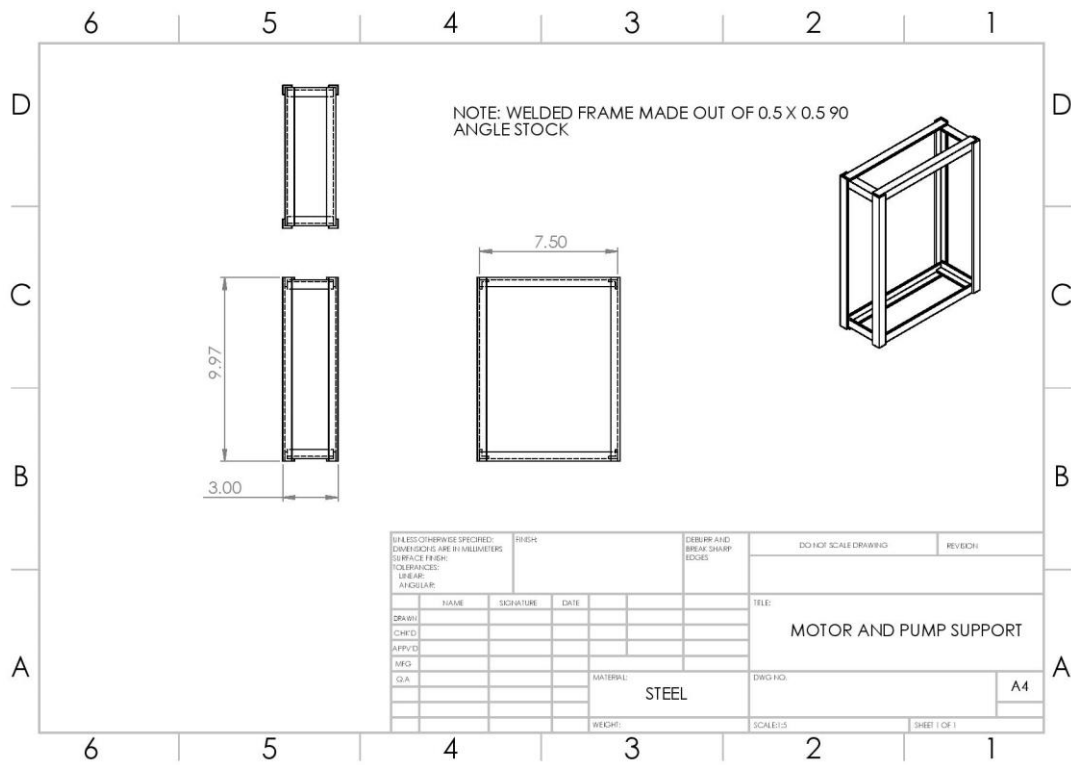

Figure 41 Motor Platform Support

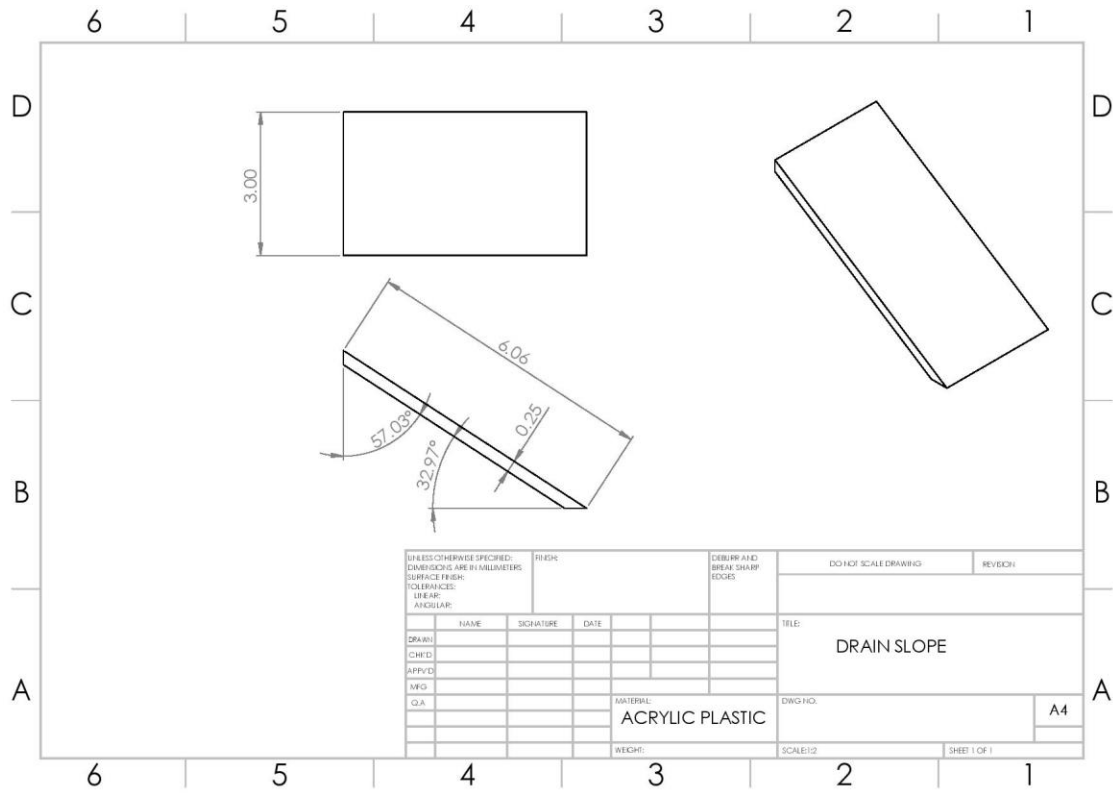

Figure 42 Sloped Drain

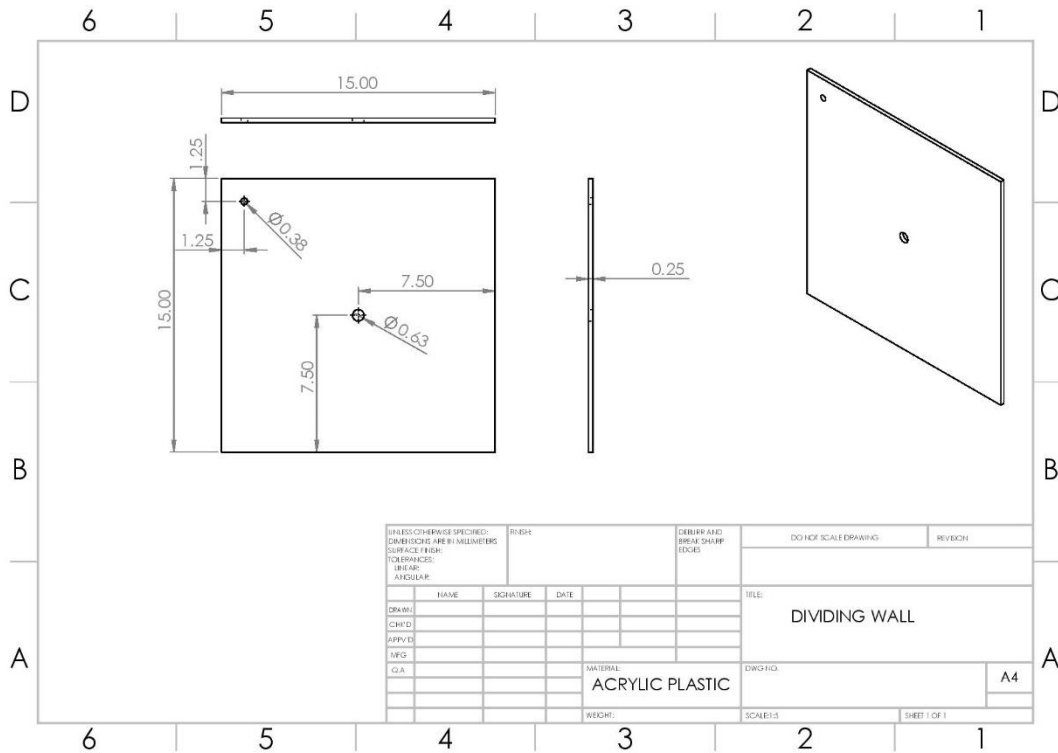
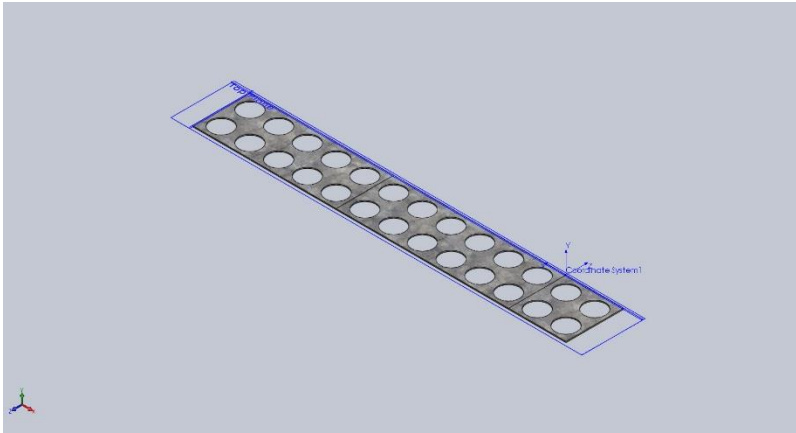

Figure 43 Waterproof Wall

13 APPENDIX E – SOLIDWORKS REPORT



## Simulation of brush base thin

Date: Thursday, December 08, 2016

Designer: Carter Fraser

Study name: Static 1

Analysis type: Static

Model Information

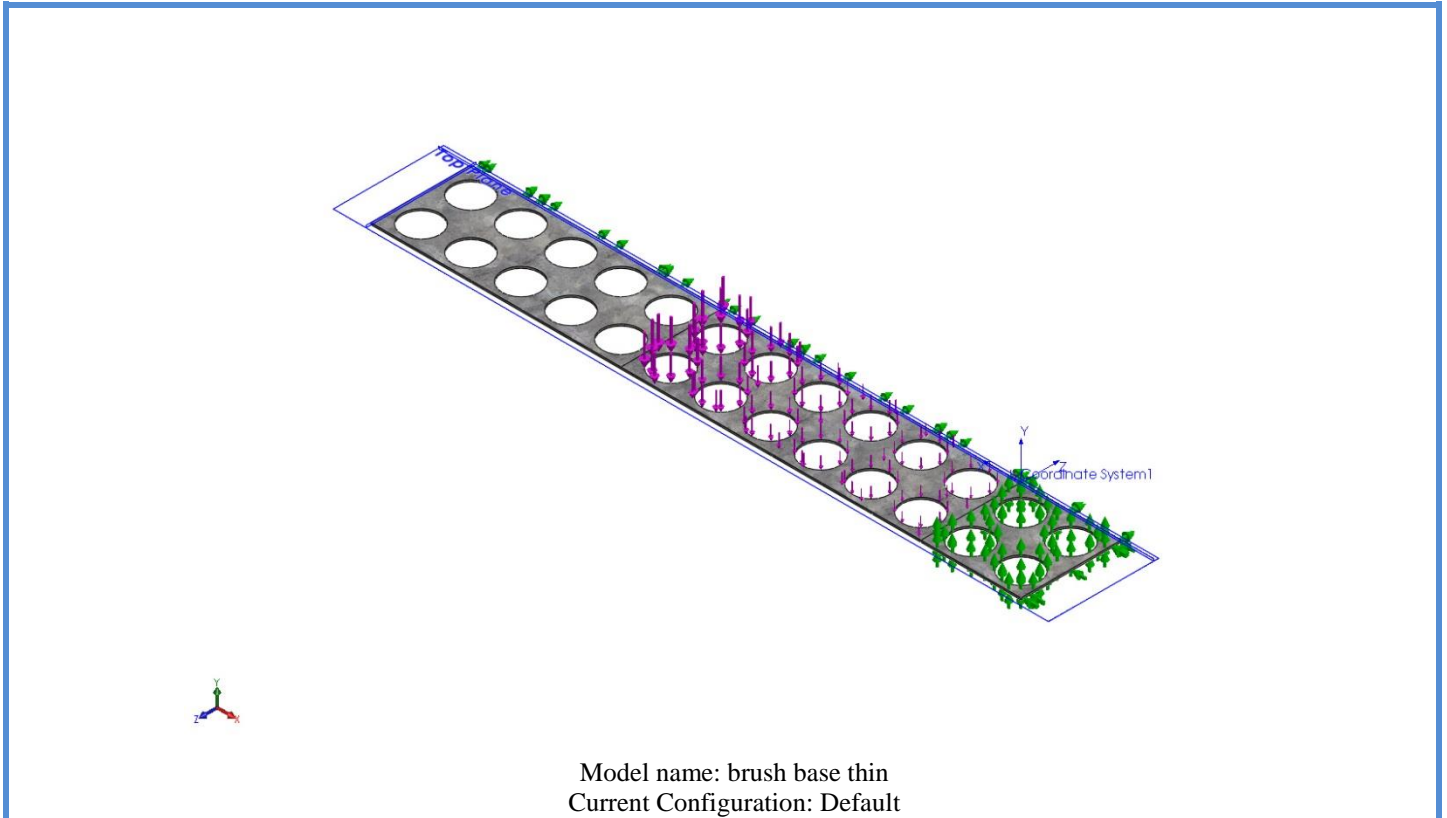

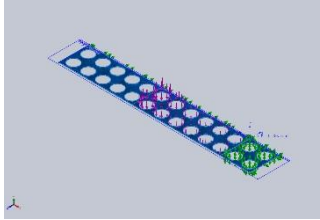
Solid Bodies			
Document Name and Reference	Treated As	Volumetric Properties	Document Path/Date Modified
Split Line3 	Solid Body	Mass:0.00875047 kg Volume:1.11188e-006 m <sup>3</sup> Density:7870 kg/m <sup>3</sup> Weight:0.0857546 N	H:\Senior design cad files\3d models\simulation\brush base thin.SLDPRT Nov 22 13:06:05 2016

Study Properties

<b>Study name</b>	Static 1
<b>Analysis type</b>	Static
<b>Mesh type</b>	Solid Mesh
<b>Thermal Effect:</b>	On
<b>Thermal option</b>	Include temperature loads
<b>Zero strain temperature</b>	298 Kelvin

<b>Include fluid pressure effects from SOLIDWORKS Flow Simulation</b>	Off
<b>Solver type</b>	FFEPlus
<b>Inplane Effect:</b>	Off
<b>Soft Spring:</b>	Off
<b>Inertial Relief:</b>	Off
<b>Incompatible bonding options</b>	Automatic
<b>Large displacement</b>	Off
<b>Compute free body forces</b>	Off
<b>Friction</b>	Off
<b>Use Adaptive Method:</b>	Off
<b>Result folder</b>	SOLIDWORKS document (H:\Senior design cad files\3d models\simulation)

## Units

<b>Unit system:</b>	SI (MKS)
<b>Length/Displacement</b>	mm
<b>Temperature</b>	Kelvin
<b>Angular velocity</b>	Rad/sec
<b>Pressure/Stress</b>	N/m <sup>2</sup>

## Material Properties

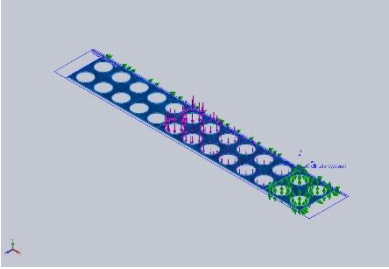
Model Reference	Properties	Components
	Name: <b>Galvanized Steel</b> Model type: <b>Linear Elastic Isotropic</b> Default failure criterion: <b>Max von Mises Stress</b> Yield strength: <b>2.03943e+008 N/m<sup>2</sup></b> Tensile strength: <b>3.56901e+008 N/m<sup>2</sup></b> Elastic modulus: <b>2e+011 N/m<sup>2</sup></b> Poisson's ratio: <b>0.29</b> Mass density: <b>7870 kg/m<sup>3</sup></b>	<b>SolidBody 1(Split Line3)(brush base thin)</b>
Curve Data:N/A		

Loads and Fixtures

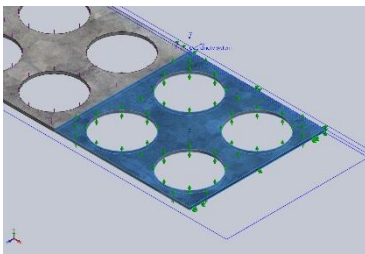
Fixture name	Fixture Image	Fixture Details
On Flat Faces-1		<b>Entities:</b> 3 face(s) <b>Type:</b> On Flat Faces <b>Translation:</b> ---, ---, 0 <b>Units:</b> mm

Resultant Forces

Components	X	Y	Z	Resultant
Reaction force(N)	-0.000309381	4.42514	-3.83976	5.8588
Reaction Moment(N.m)	0	0	0	0

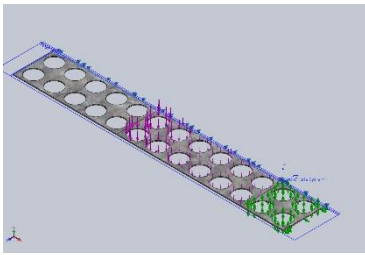
Roller/Slider-1		<b>Entities:</b> 1 face(s) <b>Type:</b> Roller/Slider
-----------------	--	--

Resultant Forces

Components	X	Y	Z	Resultant
Reaction force(N)	4.27697e-006	3.45616	-0.00128475	3.45616
Reaction Moment(N.m)	0	0	0	0

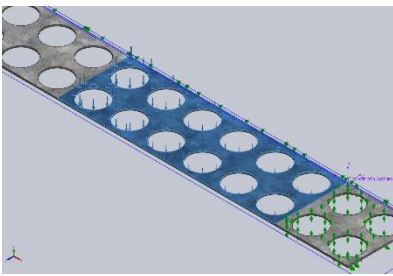
Load name	Load Image	Load Details
Force-1		<b>Entities:</b> 1 face(s) <b>Type:</b> Apply normal force <b>Value:</b> 1 lbf <b>Equation:</b> .3*exp("x")+2 (in) <b>Ref Coord Sys:</b> Coordinate System1 <b>Coord Sys Type:</b> Cartesian

## Mesh information

<b>Mesh type</b>	Solid Mesh
<b>Mesher Used:</b>	Curvature based mesh
<b>Jacobian points</b>	29 Points
<b>Maximum element size</b>	0.0284782 in
<b>Minimum element size</b>	0.0284782 in
<b>Mesh Quality</b>	High

## Mesh information - Details

<b>Total Nodes</b>	76974
<b>Total Elements</b>	36567
<b>Maximum Aspect Ratio</b>	5.0525
<b>% of elements with Aspect Ratio &lt; 3</b>	98.9
<b>% of elements with Aspect Ratio &gt; 10</b>	0
<b>% of distorted elements(Jacobian)</b>	0
<b>Time to complete mesh(hh:mm:ss):</b>	00:00:05
<b>Computer name:</b>	URB220-04

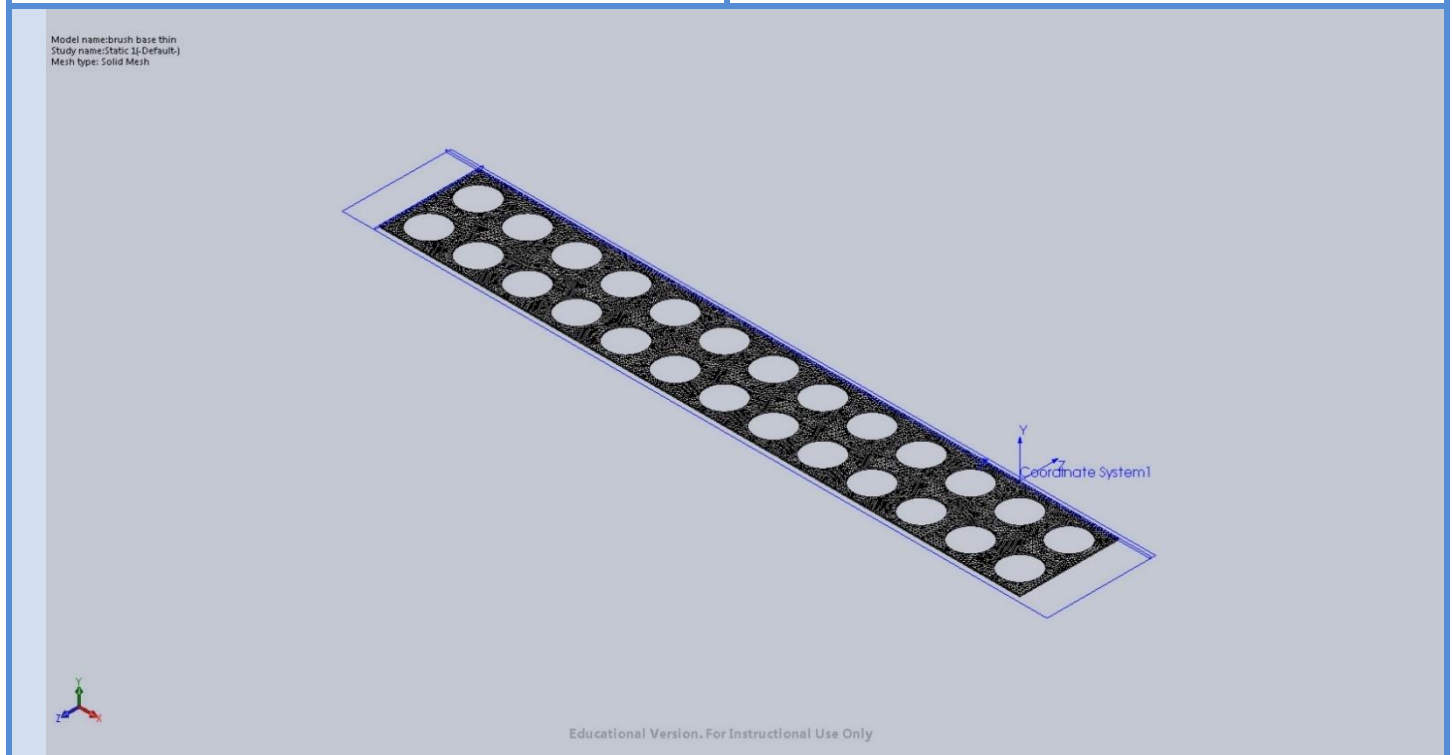

Study Results

Name	Type	Min	Max
Stress1	VON: von Mises Stress	7.1915e-006 ksi Node: 57916	120.936 ksi Node: 13751

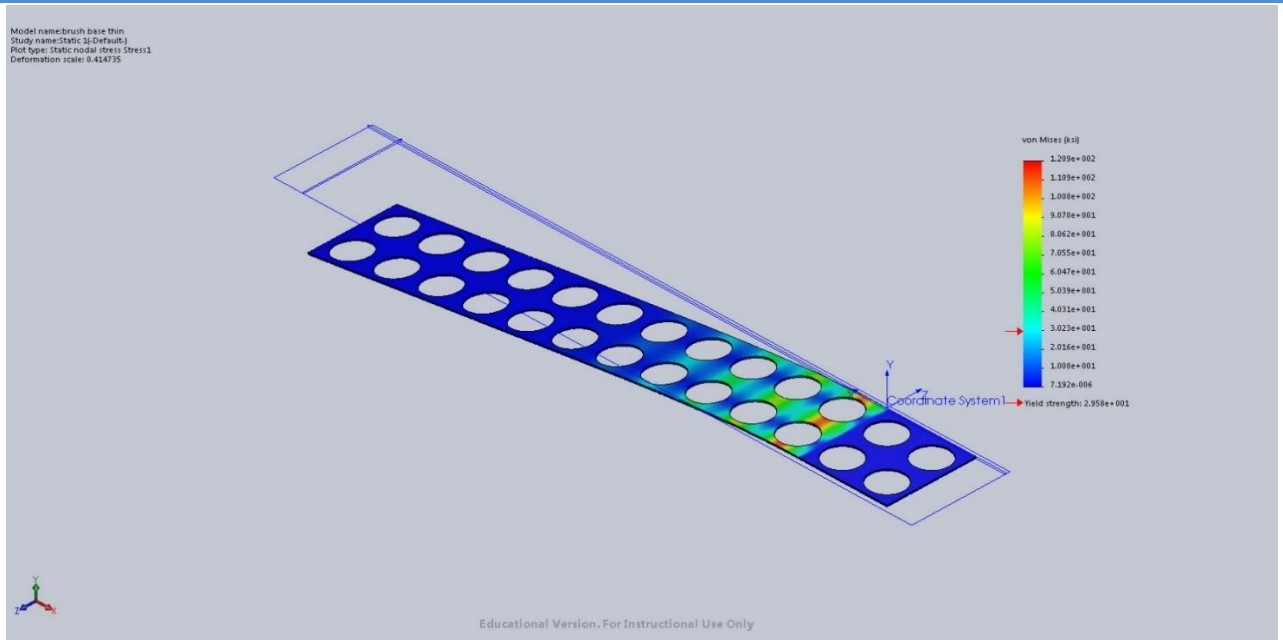

brush base thin-Static 1-Stress-Stress1

Name	Type	Min	Max
Displacement1	URES: Resultant Displacement	0 mm Node: 12	39.8087 mm Node: 11

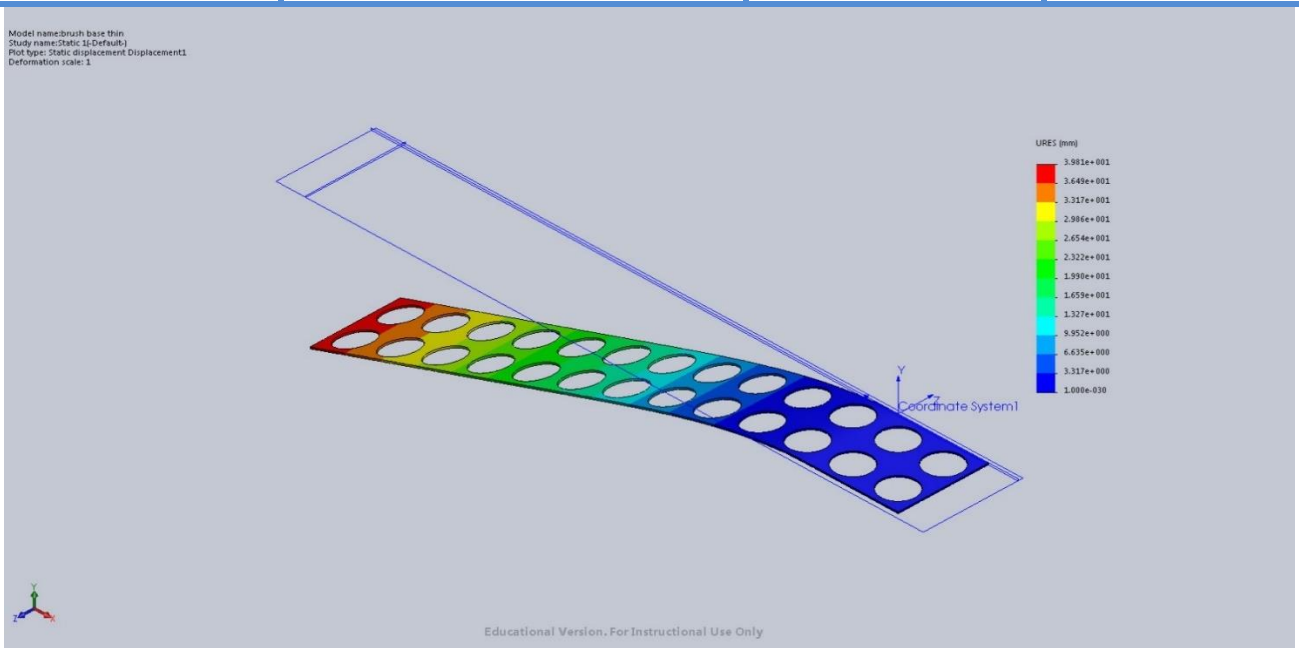

brush base thin-Static 1-Displacement-Displacement1



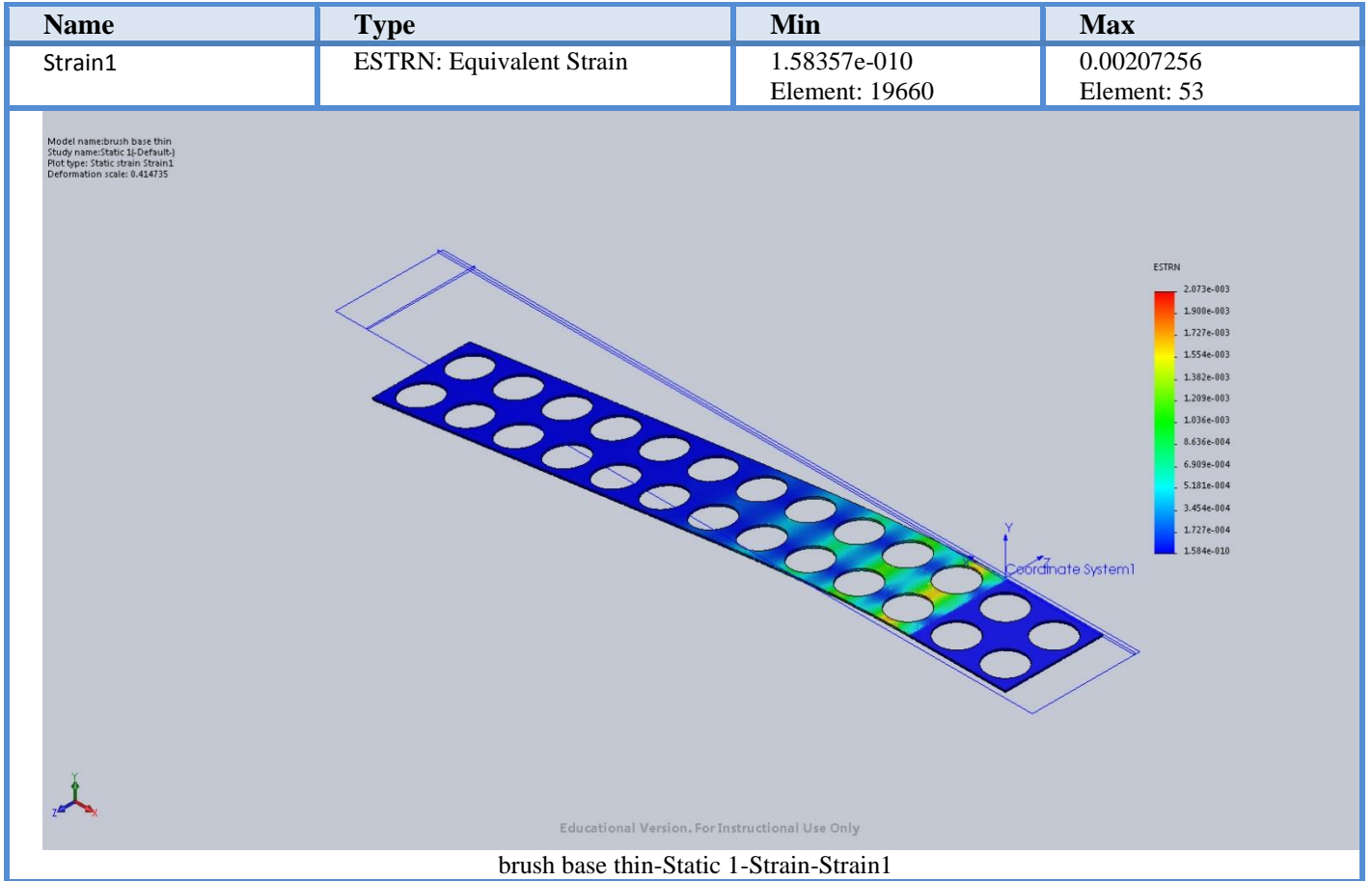

## 14 APPENDIX F – ARDUINO CODE

```
//constants
const int green = 6;
const int red = 7;
const int motor = 4;
const int pump = 3;
const int button1 = 8;
const int button2 = 9;

int state1 = HIGH;
int state2 = HIGH;

void setup(){
  Serial.begin(9600);
  pinMode(green, OUTPUT);
  pinMode(red, OUTPUT);
  pinMode(motor, OUTPUT);
  pinMode(pump, OUTPUT);
  pinMode(button1, INPUT);
  pinMode(button2, INPUT);
  digitalWrite(motor, HIGH);
  digitalWrite(pump, HIGH);
  digitalWrite(green, HIGH);
  digitalWrite(red, HIGH);
  delay(1000);
  digitalWrite(green, LOW);
  digitalWrite(red, LOW);
  delay(1000);
  digitalWrite(green, HIGH);
  digitalWrite(red, HIGH);
  delay(1000);
  digitalWrite(green, LOW);
  digitalWrite(red, LOW);
  delay(1000);
  digitalWrite(green, HIGH);
  digitalWrite(red, HIGH);
  delay(1000);
  digitalWrite(green, LOW);
  digitalWrite(red, LOW);
  delay(1000);
  digitalWrite(green, HIGH);
}

void loop(){
  state1 = digitalRead(button1);
  state2 = digitalRead(button2);
  if(state1 == HIGH){ //run main cycle
    digitalWrite(red, HIGH);
    digitalWrite(green, LOW);
```

```
    unsigned long startTime = millis();
    delay(1000);
    digitalWrite(pump, LOW);
    delay(1000);
    digitalWrite(motor, LOW);
    delay(2000);
    digitalWrite(pump, HIGH);
    delay(10000);
    digitalWrite(pump, LOW);
    delay(3000);
    digitalWrite(pump, HIGH);
    delay(10000);
    digitalWrite(pump, LOW);
    delay(1000);
    digitalWrite(motor, HIGH);
    delay(6000);
    digitalWrite(pump, HIGH);
    delay(2000);
    digitalWrite(green, HIGH);
    digitalWrite(red, LOW);
}

if(state2 == HIGH){
    while(digitalRead(button1) == LOW){
        digitalWrite(green, LOW);
        digitalWrite(red, HIGH);
        digitalWrite(pump, LOW);
    }
    digitalWrite(pump, HIGH);
    delay(2000);
    digitalWrite(green, HIGH);
    digitalWrite(red, LOW);
}
}
```

## 15 ANNOTATED BIBLIOGRAPHY

Dassault Systems, SolidWorks HELP: Defining Nonuniform Force Loads, 2015. [Online](#).

SolidWorks documentation on applying nonuniform loads was essential for our simulations for the engineering analysis. We followed many of the tips and suggestions laid out here, including the use of split lines.

Engineering Toolbox: Young Modulus of Elasticity for Metals and Alloys. [Online](#).

Engineering Toolbox is a reliable online resource for referencing material properties. We used this information when selecting materials for building and simulating our brush.

Food and Drug Administration, FDA Food Code 2009: Chapter 4 – Equipment, Utensils & Linens. Section 204: Functionality. [Online](#).

This standard covers food equipment used for restaurant purposes, which is outside the scope of our project. We used the sections on warewashers to guide us in creating the most sanitary device possible, in terms of drainage and accessibility to parts, but were obviously unable to compare it to the temperature and pressure performance of our own device.

National Science Foundation, NSF/ANSI Standard for Residential Equipment: Residential Dishwashers. Revision to NSF 184 2003, 2008. [Online](#).

A revision to a standard for residential dishwashers. Our design is not meant to compete with typical dishwashers, but instead is a replacement for handwashing. However, this was still helpful reference so that we were better aware of the material and design requirements necessary for kitchen appliances similar to ours.