

Washington University in St. Louis

## Washington University Open Scholarship

---

Mechanical Engineering Design Project Class

Mechanical Engineering & Materials Science

---

Fall 2015

### Plate Pouring IV

Alexander F. Kwakye

*Washington University in St Louis*

Carey D. Haefele

*Washington University in St Louis*

Arjay Parhar

*Washington University in St Louis*

Follow this and additional works at: <https://openscholarship.wustl.edu/mems411>



Part of the [Mechanical Engineering Commons](#)

---

#### Recommended Citation

Kwakye, Alexander F.; Haefele, Carey D.; and Parhar, Arjay, "Plate Pouring IV" (2015). *Mechanical Engineering Design Project Class*. 37.

<https://openscholarship.wustl.edu/mems411/37>

This Final Report is brought to you for free and open access by the Mechanical Engineering & Materials Science at Washington University Open Scholarship. It has been accepted for inclusion in Mechanical Engineering Design Project Class by an authorized administrator of Washington University Open Scholarship. For more information, please contact [digital@wumail.wustl.edu](mailto:digital@wumail.wustl.edu).

From a high school biology class to a small research facility, this machine will cheaply (relative to its competitors) automatically pour a layer of agar into a large number of Petri dishes in order to grow bacteria micro-cultures. Designed to be powered within a fume hood, the user simply needs to open up the containment facility, insert stacks of Petri dishes, and pour in a batch of premade agar. Within the hour, approximately 120 Petri dishes should be layered and ready for further experimentation.

---

# MEMS 411

# Senior

# Design

# Report

---

## Agar Plate Pouring IV

---

Alexander Kwakye, Carey  
Haefele, Arjay Parhar

---

Department of Mechanical Engineering and Materials Science  
School of Engineering and Applied Science  
Washington University in Saint Louis

## Table of Contents

List of Figures .....	5
List of Tables .....	6
1 Introduction .....	7
1.1 Project Problem statement.....	7
1.2 List of team members .....	7
2 Background Information Study .....	8
2.1 Design brief description - This is a description of the design problem specifically, not a description of the project as in 1.1 where other factors such as cost, fabrication, manufacturability, etc. are considered .....	8
2.2 Summary of relevant background information (such as similar existing devices or patents, patent numbers, URL's, et cetera) .....	9
3 Concept Design and Specification.....	10
3.1 User needs, metrics, and quantified needs equations. This will include three main parts:.....	10
3.1.1 Record of the user needs interview .....	10
3.1.2 List of identified metrics .....	17
3.1.3 Table/list of quantified needs equations .....	18
3.2 Four (4) concept drawings .....	22
3.2.1 Concept #1 (Conveyor Belt) .....	22
3.2.2 Concept #2 (P.A.M.) .....	23
3.2.3 Concept #3 (The CLAW) .....	24
3.2.4 Concept #4 (Gumball) .....	25
3.3 A concept selection process. This will have three parts: .....	26
3.3.1 Concept scoring (not screening) .....	26
3.3.2 Preliminary analysis of each concept's physical feasibility .....	26
3.3.3 Final summary.....	27
3.4 Proposed performance measures for the design .....	27
3.5 Design constraints (include at least one example of each of the following) .....	28
3.5.1 Functional.....	28
3.5.2 Safety .....	29
3.5.3 Quality.....	29

3.5.4	Manufacturing.....	29
3.5.5	Timing.....	29
3.5.6	Economic.....	29
3.5.7	Ergonomic .....	29
3.5.8	Ecological .....	29
3.5.9	Aesthetic .....	29
3.5.10	Life cycle.....	30
3.5.11	Legal .....	30
4	Embodiment and fabrication plan .....	31
4.1	Embodiment drawing.....	31
4.2	Initial Parts List .....	34
4.3	Draft detail drawings for each manufactured part.....	36
4.4	Description of the design rationale for the choice/size/shape of each part.....	45
4.5	Gantt chart.....	47
5	Engineering analysis.....	48
5.1	Engineering analysis proposal.....	48
5.1.1	A form, signed by your section instructor (insert your form here).....	48
5.2	Engineering analysis results.....	49
5.2.1	Motivation. Describe why/how the before analysis is the most important thing to study at this time. How does it facilitate carrying the project forward?.....	49
5.2.2	Summary statement of analysis done. Summarize, with some type of readable graphic, the engineering analysis done and the relevant engineering equations .....	49
5.2.3	Methodology. How, exactly, did you get the analysis done? Was any experimentation required? Did you have to build any type of test rig? Was computation used? .....	52
5.2.4	Results. What are the results of your analysis study? Do the results make sense? .....	52
5.2.5	Significance. How will the results influence the final prototype? What dimensions and material choices will be affected? This should be shown with some type of revised embodiment drawing. Ideally, you would show a “before/after” analysis pair of embodiment drawings. ....	53
5.2.6	Summary of code and standards and their influence. Similarly, summarize the relevant codes and standards identified and how they influence revision of the design. ....	54
5.3	Risk Assessment.....	54
5.3.1	Risk Identification.....	54

5.3.2	Risk Analysis (This is based on your project engineering analysis. Tools include simulation, happiness equations, calculation by hand or with SolidWorks, MATLAB, etc.). Discuss risk as it pertains to your performance specification, cost, and schedule .....	55
5.3.3	Risk Prioritization .....	55
6	Working prototype.....	56
6.1	A preliminary demonstration of the working prototype (this section may be left blank). .....	56
6.2	A final demonstration of the working prototype (this section may be left blank). .....	56
6.3	At least two digital photographs showing the prototype.....	57
6.4	A short video clip that shows the final prototype performing .....	58
6.5	At least four (4) additional digital photographs and their explanation .....	58
7	Design documentation.....	63
7.1	Final Drawings and Documentation.....	63
7.1.1	A set of engineering drawings that includes all CAD model files and all drawings derived from CAD models. <i>Include units on all CAD drawings.</i> See Appendix C for the CAD models. ....	63
7.1.2	Sourcing instructions.....	74
7.2	Final Presentation .....	75
7.2.1	A live presentation in front of the entire class and the instructors (this section may be left blank) .....	75
7.2.2	A link to a video clip version of 1 .....	75
7.3	Teardown .....	76
8	Discussion.....	76
8.1	Using the final prototype produced to obtain values for metrics, evaluate the quantified needs equations for the design. How well were the needs met? Discuss the result.....	76
8.2	Discuss any significant parts sourcing issues? Did it make sense to scrounge parts? Did any vendor have an unreasonably long part delivery time? What would be your recommendations for future projects? .....	76
8.3	Discuss the overall experience:.....	77
8.3.1	Was the project more of less difficult than you had expected?.....	77
8.3.2	Does your final project result align with the project description? .....	77
8.3.3	Did your team function well as a group? .....	77
8.3.4	Were your team member's skills complementary?.....	77
8.3.5	Did your team share the workload equally?.....	77
8.3.6	Was any needed skill missing from the group? .....	77

8.3.7 Did you have to consult with your customer during the process, or did you work to the original design brief?..... 78

8.3.8 Did the design brief (as provided by the customer) seem to change during the process? 78

8.3.9 Has the project enhanced your design skills?..... 78

8.3.10 Would you now feel more comfortable accepting a design project assignment at a job? 78

8.3.11 Are there projects that you would attempt now that you would not attempt before? .... 78

9 Appendix A - Parts List ..... 78

10 Appendix B - Bill of Materials..... 80

11 Appendix C - CAD Models ..... 81

12 Annotated Bibliography (limited to 150 words per entry) ..... 82

### List of Figures

Figure 1: Use insert object to insert a PowerPoint slide. Right click on object to add caption. .... **Error! Bookmark not defined.**

Figure 2: Use insert object to insert an image. Right click on image to insert a caption..... 7

Figure 3: Insert a chart using insert object. Right click on object to add caption..... **Error! Bookmark not defined.**

**List of Tables**

Table 1: Excel worksheet ..... **Error! Bookmark not defined.**  
Table 2: Word table of values ..... **Error! Bookmark not defined.**



# 1 Introduction

## 1.1 Project Problem statement

Biologists culture microbes on agar in Petri dishes under sterile conditions. A biologist can pour their own plates or purchase them on Amazon for \$4. To save time and reduce costs, the customer, a biologist at the STLCC Biobench CRO wants an automated process to pour plates. In order to automate this process, a design needs to contain a reservoir for agar medium, a valve to regulate flow, a mechanical device to time motion and move plates for the pour. The entire design must fit within a pre specified fume hood, be sterile, easy to clean, and pour approximately 120 plates per hour.

This is a high-level statement, specifically, the description you were given on the project ideas list combined with more details from your customer interviews, concept development, prototypes, etc.

This statement should evolve as your project progresses.

## 1.2 List of team members



Figure 1: The slide contains the name of team and a list of the team members.

## 2 Background Information Study

### 2.1 Design brief description - This is a description of the design problem specifically, not a description of the project as in 1.1 where other factors such as cost, fabrication, manufacturability, etc. are considered

Abiding by the final result of pouring Petri dishes, the machine must carefully handle the dishes and the agar in order to promote healthy culture growth. The agar solution needs to be maintained at a specified temperature range during storage and must be poured in a manner that minimizes splashing or bubble formation. For customer simplicity, the product should require little assembly, be prepared in a short amount of time, and require as little cleanup afterwards as possible.

At the same time, the project was allotted to \$400. The fabrication of the product also needed to be made out of some material that held some structural stability features and had a high degree of machinability. The design would have to be easy to manufacture within the allotted time of 2 months.

## 2.2 Summary of relevant background information (such as similar existing devices or patents, patent numbers, URL's, et cetera)

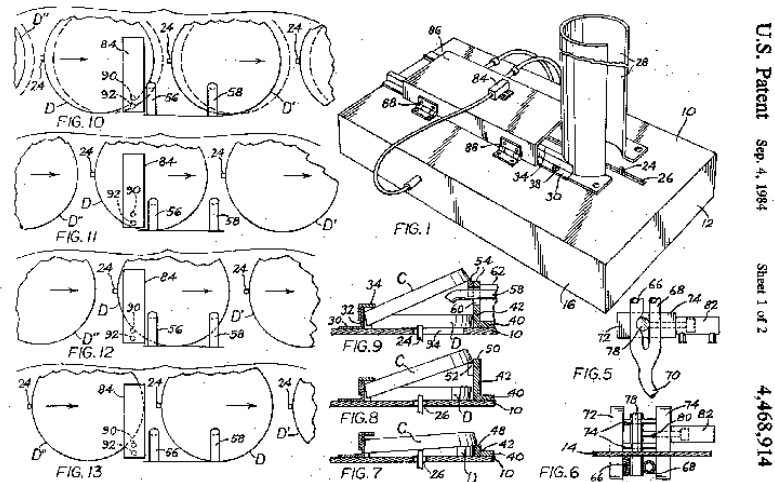

Figure 2 : The figure is a schematic diagram of an apparatus for filling Petri dishes specifically US Patent 4468914 A.

U.S. Patent Oct. 16, 1979 Sheet 1 of 7 4,170,861

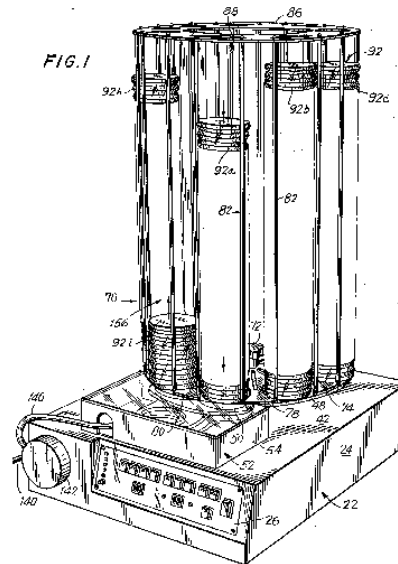

Figure 3 : The figure is the second schematic diagram of an apparatus for filling Petri dishes specifically US Patent 4170861 A.

- Method for providing storable plates filled with a biological culture medium
  - Patent: WO 2008049756 A1

### 3 Concept Design and Specification

#### 3.1 User needs, metrics, and quantified needs equations. This will include three main parts:

##### 3.1.1 Record of the user needs interview

<b>Customer Data: Agar Plate Pouring Device(AP)</b> Customer: Professor John Goodloe  Address: Saint Louis Community College's Bio Research & Development Growth Park Date: 12 September 2015			
Question	Customer Statement	Interpreted Need	Importance
What was the conventional method used pouring agar plates?	12 liter glass carboy was used to house 4 liters of the agar solution.	AP needs to be able to carry a large size of agar solution	5
	At the bottom of the tub, a hose was ace inserted to place a rubber tubing, not a tipon, along with a small section of glass tubing at the end so that it would fit.	AP needs to have a way to eject agar solution into the petri dishes	5
	A pitch clamp was used.		
	Petri plates were kept in a stack of 10.		
	A technique of filling the plates from an ascending order was used.		
	Did not do it in the hood, but the hood is a nice idea because it prevents the plates from being interfered with.	AP needs to able to stack number of petri dishes.	5
	Keeping it sterile, managing the packing and storage sequences will also be another problem.	AP should fill petri dishes from an ascending order.	4
Needs to be heated.			
Needs to be sterile.	AP needs to be functional within a fume hood.	5	

		<p>AP needs to be sterile before and after use.</p>	5
		<p>AP needs to keep the agar solution well heated.</p> <p>AP needs to be sterile.</p>	5
			5
<p>You talked about rubber tubing, would you throw that away, afterwards?</p>	<p>Overtime, the effect of steam would cause the rubber tubing to lose pigment and also get brittle.</p> <p>This would happen in the span of months.</p> <p>The lifespan would be 6 months to 1 year.</p> <p>It would wrapped tightly with copper wires to adjust for the overtime stiffness. But later on, the adjustment of plastic wire ties was used because it was firm and less tight than the copper wires.</p>	<p>AP's tubing needs to stay flexible</p> <p>AP's tubing would need to be durable for extended usage.</p> <p>AP's tubing would need good supporting backbone to prolong wear and tear time period.</p>	<p>5</p> <p>3</p> <p>4</p>

<p>And this is as high as you would it? (speaking of the stacks of petri dishes being a stack of 5.)</p>	<p>Commercial products would stack them in 20.</p> <p>Some would stack it in 4, and that was in the fume hood.</p> <p>The higher the stack is, the more chances you take from the system being unbalanced.</p> <p>He poured in stacks of 10.</p>	<p>AP would need to do at most stacks of 10 petri dishes.</p> <p>AP could operate at stacking at a reasonable rate of 4 petri dishes per cycle</p> <p>AP needs to be at an optimal stacking quantity for conserving space and keeping stack of petri dishes statically determinate.</p>	<p>3</p> <p>4</p> <p>5</p>
<p>How high the splash be? What is tolerance level for the splash?</p>	<p>Commercial products claim to do 900 plates/hour</p> <p>Plates are 15mm high by 100mm diameter.</p> <p>As long you keep it from splashing, it's good.</p> <p>Keep the nozzle at about a 1/3 way into the dish, tilted, and kept at a good flowrate, you shouldn't have that problem.</p> <p>The pinch clamp held about a quarter inch diameter hose to pour the agar into the dishes.</p> <p>It doesn't need to be in a hurry.</p>	<p>AP does not need to compete with on the rate of high-end petri filler products, but be a reasonable choice</p> <p>AP must support 15mm x 100 mm petri dishes.</p> <p>AP must minimize the effect of splashing while inserting the solution into the petri dishes.</p> <p>AP insertion must be at a reasonable height from the base of the petri dishes to inject agar solution.</p> <p>AP's insertion outlet would need to be at least ¼ -inch diameter</p> <p>AP does not need to have a strict rate.</p>	<p>3</p> <p>5</p> <p>5</p> <p>4</p> <p>3</p> <p>2</p>

<p>So we don't have to deliver exactly so many mL?</p>	<p>Commercial products use parabolic pumps to regulate the time and the amount of agar poured into the dishes.</p> <p>Commercially, it would be stacked in 30, and that would take about 1 liter.</p> <p>About 33 mL per dish.</p> <p>Want at least halfway of the height of the dish</p> <p>If too short, the agar would dry out.</p> <p>Not that critical, but it should be consistent</p> <p>You don't want it to solidify in the flask.</p> <p>You don't want bubbles to form.</p> <p>Bubbles form when the agar solution cools down while being poured. The solution needs to be at 60-70 degrees C because of antibiotics.</p>	<p>AP needs some form of regulation to control the rate of agar petri dishes completed.</p> <p>AP should be able to fill in 30 petri dishes with 1 liter of agar solution.</p> <p>AP would fill in 33 mL of agar solution into each petri dish.</p> <p>AP must fill the petri dishes halfway up from the bottom of the petri dish.</p> <p>AP must fill the petri dish to a threshold were agar will not dry out inside the petri dish.</p> <p>AP should prevent the agar solution from solidifying within the device.</p> <p>AP should not have any form of bubbles from the agar solution</p> <p>AP must heated within the temperature threshold to prevent the agar solution from producing bubbles.</p>	<p>5</p> <p>4</p> <p>4</p> <p>2</p> <p>4</p> <p>5</p> <p>4</p> <p>4</p>

Considering power, would you want the device to be battery operated or outlet?	Outlet would be preferred.	AP should receive its power through a wall outlet.	3
Do you think that pouring the Erlenmeyer flask into a reservoir and then delivering that into our machine is the best idea?	I'm not sure. That might be the best way. You could pump it into the system.  It could affect the bubbling.  Could use coils to keep the reservoir constantly heated.  Could also use hot plate technology.	AP has to maintain the agar solution's temperature.  AP needs to find a way to transfer the agar solution into the ejector.  AP's solution transfer needs to flow at a reasonable rate where bubbling will not occur.  AP needs to find a technique to keep the solution at a temperature range.	5  5  4  5
Does it have to be portable?	Yes. It would be in the hood for half a day.	AP does need to be portable. AP should require little installation and packing	5 4
Can the fume hood shields be lifted up?	It can be lifted up.	AP's height limit should be near the height of the fume hood.	4
When it comes down to price range, was is a reasonable amount?	I have no idea.	AP cost should be reasonable, around \$500.	4



What do mean by 120 plates per hour? Do you mean cooled or heated?	It just needs to be plated at 120 plates per hour and then it could be cooled.	AP should be able to fill 120 plates while the agar is still heated.	5
Who is exactly is going to be using this device?  How much experienced does this person has to have?	It just needs to be simple.  Maybe just to be from a press of a button.  I don't think it would need to be computer operated.  There should be some level of safe-guards implemented because of the heated portion of the device.	AP's user input needs to be explicitly simple.    AP has the possibility to not require computer input.  AP should have some safety precautions placed under the heating of the reservoir.	4    2  3
What is your ideal experience of the device?	Nominal uses.  2-Liter of agar solution for 60 plates	AP will need to capable of working on the regular.  AP should be able to take in a certain amount of agar solution and output a certain number of plates.	5  3
Does the petri dishes need to cover up after the agar pouring?	Yes  Also, I've seen UV being used to sterilize.  Air particles wouldn't be a problem because its in a fume hood	AP needs to close up petri dishes after inserting agar solution.  AP uses some form of sanitization to prevent foreign particles from getting into the agar petri dishes.	3  2

<p>How many parts are you willing to clean up after the use of the device?</p>	<p>It would make sense to do it all in one tank and a tube leading to the glass tip. And then you could wash that out.</p> <p>Glass would be difficult to work with because of its sensitivity to heat.</p> <p>Pyrex –glass kind of material.</p> <p>You would use hot water with lab soap to clean out the reservoir.</p>	<p>AP components that need cleanup should be a reasonable quantity.</p> <p>AP’s piping would need to be some reasonable material that is capable of withstanding temperature differentials.</p> <p>AP’s piping should be easily clean with a mid-solution of water and detergent.</p>	<p>2</p> <p>3</p> <p>3</p>
<p>So you would like to see this be detachable?</p>	<p>Yes</p> <p>The question is how easily can you clean that?</p> <p>You would want it to be too difficult to clean.</p>	<p>AP needs to be detachable.</p> <p>AP needs to be easily detachable.</p>	<p>2</p> <p>2</p>
<p>What would you do with the extra agar left over?</p>	<p>You would just throw it away.</p>	<p>AP’s reservoir needs to be detachable.</p> <p>AP’s reservoir needs to be easily cleaned.</p>	<p>3</p> <p>4</p>

### 3.1.2 List of identified metrics

Need Number	Need	Importance
1	AP opens and closes the Petri dishes after inserting agar solution.	3
2	AP needs to be able to stack number of Petri dishes.	5
3	AP fills Petri dishes from an ascending order.	2
4	AP needs to be able to fit within the dimensions of the fume hood.	5
5	AP uses some form of sanitization to prevent foreign particles from getting into the agar Petri dishes before and after use.	4
6	AP needs to keep the agar solution well heated from the range of 60-70° C, to prevent the agar solution from producing bubbles.	5
7	AP must support 15mm x 100 mm Petri dishes.	5
8	AP must minimize the effect of splashing and sloshing while inserting the solution into the Petri dishes.	5
9	AP uses some form of computer regulation to control the rate of agar Petri dishes completed.	4
10	AP should be able to fill 120 plates while the agar is still heated with 4 liters of agar solution.	5
11	AP should receive its power through a wall outlet.	3
12	AP should require little assembly and packing.	3
13	AP cost should be reasonable.	3
14	AP must be made in a reasonable amount of time.	5
15	AP has a reservoir that can hold 4 liters of agar solution.	5
16	AP mimics human behavior.	4

3.1.3 Table/list of quantified needs equations

Agar Plate Pouring Concept #1	Metric													Need Happiness	Importance Weight (all entries should add up to 1)	Total Happiness Value	
	Moves Lid	Cost	Reservoir's Volume	Fill Rate	Temperature	Diameter	Safety	Agar Solution Requirements	Mobility Requirements	Petri Dish Requirements	Electronic Requirements	Build Capabilities	Base Area				
Need	1	2	3	4	5	6	7	8	9	10	11	12	13				
1 AP opens and closes petri dishes	0.5									0.5					1	0.045455	0.04545455
2 AP can stack petri dishes	0.1									0.9					1	0.075758	0.07575758
3 Fills petri dishes in ascending order	0.2									0.8					1	0.030303	0.03030303
4 Fits inside fume hood									0.2				0.8		0.72026144	0.075758	0.05456526
5 Heat agar solution					1										1	0.060606	0.06060606
6 Uses sanitation system					0.4		0.4	0.2							0.85	0.075758	0.06439394
7 Supports 15mmx100mm dishes						0.8				0.2					1	0.075758	0.07575758
8 Minimizes splashes				0.5				0.5							0.625	0.075758	0.04734848
9 Uses computer regulation				0.3							0.5	0.2			0.68389831	0.060606	0.04144838
10 can fill 120 plates per hour			0.2	0.8											0.6	0.075758	0.04545455
11 Powered via wall outlet								0.3			0.7				0.925	0.045455	0.04204545
12 Easy to assemble and storage									1						0.5	0.045455	0.02272727
13 Cost is reasonable		1													0.27272727	0.045455	0.01239669
14 Built in a reasonable amount of time												1			0.16949153	0.075758	0.01284027
15 Holds four liters of solution			1												1	0.075758	0.07575758
16 mimics human behavior													1		0.16949153	0.060606	0.01027221
<b>Units</b>	Binary	Dollars	L	Dishes/ hour	Celsius	Binary	Danger Level Intensity	Number	Number	Number	Number	Days	in^2			<b>Total Happiness</b>	<b>0.71712888</b>
<b>Best Value</b>	1	50	4	130	70	1	1	2	2	4	2	1	0				
<b>Worst Value</b>	0	600	1	110	60	0	5	0	0	0	0	60	1224				
<b>Actual Value</b>	1	450	4	120	70	1	2	1.5	1	4	2	50	275				
<b>Normalized Metric Happiness</b>	1	0.272727	1	0.5	1	1	0.75	0.75	0.5	1	1	0.169492	0.775327				

Agar Plate Pouring Concept #2	Metric													Need Happiness	Importance Weight (all entries should add up to 1)	Total Happiness Value
	Moves Lid	Cost	Reservoir's Volume	Fill Rate	Temperature	Diameter	Safety	Agar Solution Requirements	Mobility Requirements	Petri Dish Requirements	Electronic Requirements	Build Capabilities	Base Area			
Need	1	2	3	4	5	6	7	8	9	10	11	12	13			
1 AP opens and closes petri dishes	0.5									0.5				1	0.045455	0.045455
2 AP can stack petri dishes	0.1									0.9				1	0.075758	0.075758
3 Fills petri dishes in ascending order	0.2									0.8				1	0.030303	0.030303
4 Fits inside fume hood									0.2				0.8	0.891176	0.075758	0.067513
5 Heat agar solution					1									0	0.060606	0
6 Uses sanitation system					0.4		0.4	0.2						0.4	0.075758	0.030303
7 Supports 15mmx100mm dishes						0.8				0.2				1	0.075758	0.075758
8 Minimizes splashes				0.5				0.5						0.75	0.075758	0.056818
9 Uses computer regulation				0.3							0.5	0.2		0.700847	0.060606	0.042476
10 can fill 120 plates per hour			0.2	0.8										0.6	0.075758	0.045455
11 Powered via wall outlet							0.3				0.7			0.85	0.045455	0.038636
12 Easy to assemble and storage									1					0.75	0.045455	0.034091
13 Cost is reasonable		1												0.454545	0.045455	0.020661
14 Built in a reasonable amount of time												1		0.254237	0.075758	0.01926
15 Holds four liters of solution			1											1	0.075758	0.075758
16 mimics human behavior												1		0.254237	0.060606	0.015408
<b>Units</b>	Binary	Dollars	L	Dishes/	Celsius	Binary	Danger	l	Number	Number	Number	Number	Days	in^2	<b>Total Happiness</b>	<b>0.658244</b>
<b>Best Value</b>	1	50	4	130	70	1	1	2	2	4	2	1	0			
<b>Worst Value</b>	0	600	1	110	60	0	5	0	0	0	0	0	60	1224		
<b>Actual Value</b>	1	350	4	120	60	1	3	2	1.5	4	2	45	90			
<b>Normalized Metric Happiness</b>	1	0.454545	1	0.5	0	1	0.5	1	0.75	1	1	0.254237	0.926471			

Agar Plate Pouring Concept #3		Metric													Need Happiness	Importance Weight (all entries should add up to 1)	Total Happiness Value
		Moves Lid	Cost	Reservoir's Volume	Fill Rate	Temperature	Diameter	Safety	Agar Solution Requirements	Mobility Requirements	Petri Dish Requirements	Electronic Requirements	Build Capabilities	Base Area			
	Need	1	2	3	4	5	6	7	8	9	10	11	12	13			
1	AP opens and closes petri dishes	0.5									0.5				1	0.045455	0.045455
2	AP can stack petri dishes	0.1									0.9				1	0.075758	0.075758
3	Fills petri dishes in ascending order	0.2									0.8				1	0.030303	0.030303
4	Fits inside fume hood									0.2				0.8	0.555882	0.075758	0.042112
5	Heat agar solution					1									0	0.060606	0
6	Uses sanitation system					0.4		0.4	0.2						0.4	0.075758	0.030303
7	Supports 15mmx100mm dishes						0.8				0.2				1	0.075758	0.075758
8	Minimizes splashes				0.5				0.5						1	0.075758	0.075758
9	Uses computer regulation				0.3							0.5	0.2		0.850847	0.060606	0.051567
10	can fill 120 plates per hour			0.2	0.8										1	0.075758	0.075758
11	Powered via wall outlet							0.3				0.7			0.85	0.045455	0.038636
12	Easy to assemble and storage									1					0.25	0.045455	0.011364
13	Cost is reasonable		1												0.636364	0.045455	0.028926
14	Built in a reasonable amount of time												1		0.254237	0.075758	0.01926
15	Holds four liters of solution			1											1	0.075758	0.075758
16	mimics human behavior												1		0.254237	0.060606	0.015408
	<b>Units</b>	Binary	Dollars	L	Dishes/	Celsius	Binary	Danger I	Number	Number	Number	Number	Days	in^2	<b>Total Happiness</b>	<b>0.676713</b>	
	<b>Best Value</b>	1	50	4	130	70	1	1	2	2	4	2	1	0			
	<b>Worst Value</b>	0	600	1	110	60	0	5	0	0	0	0	60	1224			
	<b>Actual Value</b>	1	250	4	130	60	1	3	2	0.5	4	2	45	450			
	<b>Normalized Metric Happiness</b>	1	0.636364	1	1	0	1	0.5	1	0.25	1	1	0.254237	0.632353			

Agar Plate Pouring Concept #4	Metric													Need Happiness	Importance Weight (all entries should add up to 1)	Total Happiness Value	
	Moves Lid	Cost	Reservoir's Volume	Fill Rate	Temperature	Diameter	Safety	Agar Solution Requirements	Mobility Requirements	Petri Dish Requirements	Electronic Requirements	Build Capabilities	Base Area				
Need	1	2	3	4	5	6	7	8	9	10	11	12	13				
1 AP opens and closes petri dishes	0.5									0.5					0.875	0.045455	0.039773
2 AP can stack petri dishes	0.1									0.9					0.775	0.075758	0.058712
3 Fills petri dishes in ascending order	0.2									0.8					0.8	0.030303	0.024242
4 Fits inside fume hood									0.2				0.8		0.786601	0.075758	0.059591
5 Heat agar solution					1										1	0.060606	0.060606
6 Uses sanitation system					0.4			0.4	0.2						0.95	0.075758	0.07197
7 Supports 15mmx100mm dishes						0.8				0.2					0.95	0.075758	0.07197
8 Minimizes splashes				0.5				0.5							0.625	0.075758	0.047348
9 Uses computer regulation				0.3							0.5	0.2			0.700847	0.060606	0.042476
10 can fill 120 plates per hour			0.2	0.8											0.466667	0.075758	0.035354
11 Powered via wall outlet								0.3			0.7				1	0.045455	0.045455
12 Easy to assemble and storage									1						0.75	0.045455	0.034091
13 Cost is reasonable		1													0.727273	0.045455	0.033058
14 Built in a reasonable amount of time													1		0.254237	0.075758	0.01926
15 Holds four liters of solution			1												0.333333	0.075758	0.025253
16 mimics human behavior													1		0.254237	0.060606	0.015408
<b>Units</b>	Binary	Dollars	L	Dishes/	Celsius	Binary	Danger Level Intensity	Number	Number	Number	Number	Days	in^2	<b>Total Happiness</b>	<b>0.669158</b>		
<b>Best Value</b>	1	50	4	130	70	1	1	2	2	4	2	1	0				
<b>Worst Value</b>	0	600	1	110	60	0	5	0	0	0	0	60	1224				
<b>Actual Value</b>	1	200	2	120	70	1	1	1.5	1.5	3	2	45	250				
<b>Normalized Metric Happiness</b>	1	0.727273	0.333333	0.5	1	1	1	0.75	0.75	0.75	1	0.254237288	0.795752				

An enlarge image of The Happiness equation charts can be view from the following Excel file.



Senior Design  
Happiness Matrix.xls

### 3.2 Four (4) concept drawings

#### 3.2.1 Concept #1 (Conveyor Belt)

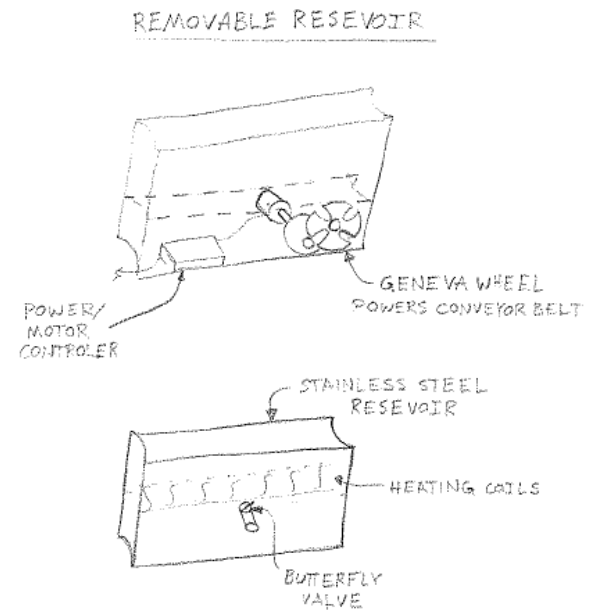
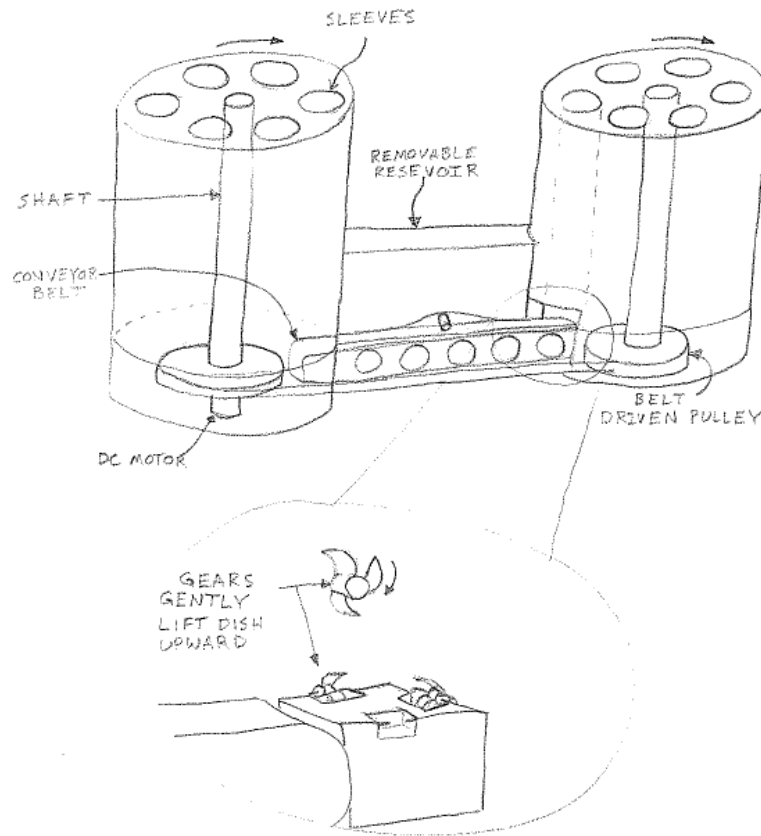



3.2.2 Concept #2 (P.A.M.)

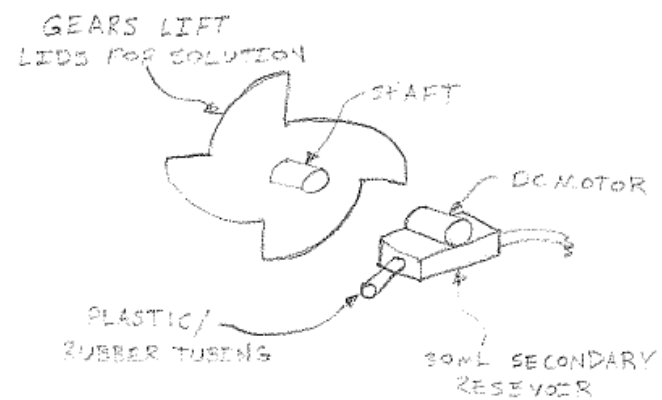
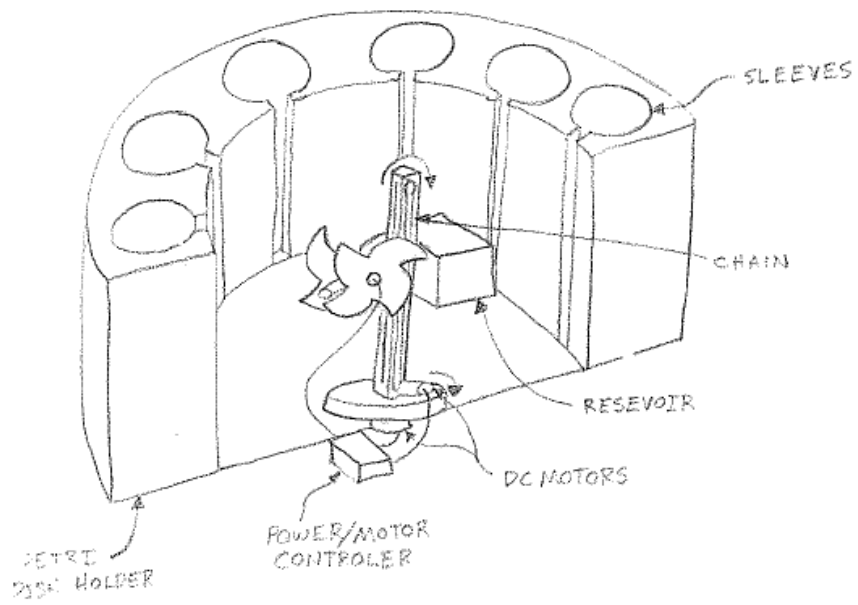

### 3.2.3 Concept #3 (The CLAW)

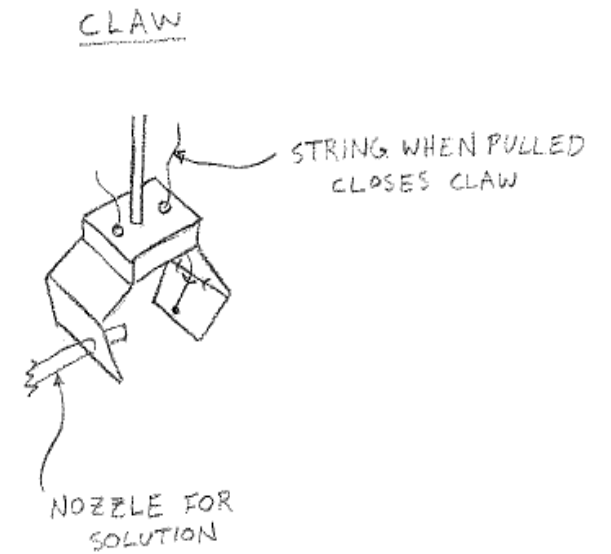
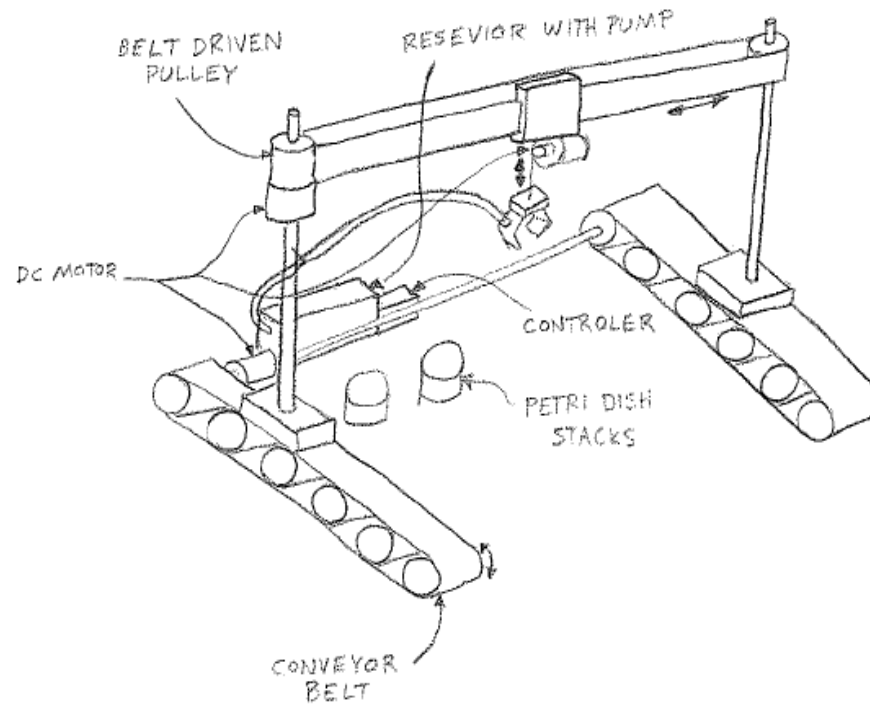

3.2.4 Concept #4 (Gumball)

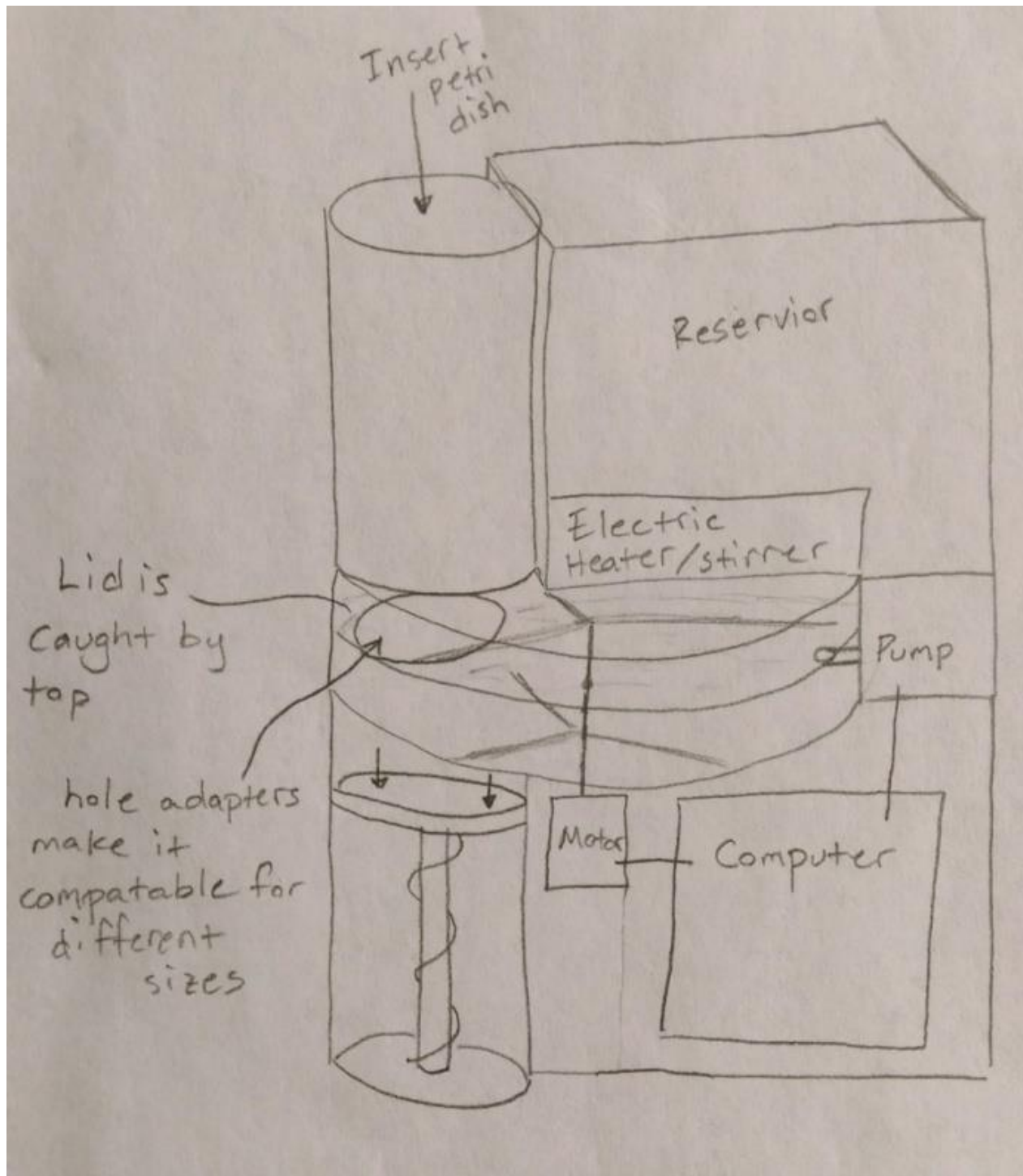

### 3.3 A concept selection process. This will have three parts:

#### 3.3.1 Concept scoring (not screening)

Concept #1 (Conveyor Belt) – 0.71712888

Concept #2 (P.A.M.) – 0.658244

Concept #3 (The CLAW) – 0.676713

Concept #4 (Gumball) – 0.669158

#### 3.3.2 Preliminary analysis of each concept's physical feasibility

##### Concept 1: Assembly Line

Utilizing two multilayered revolving pistol magazine-like structures, concept one requires the least amount of programming out of any of the designs. Apart from the occasional turn of each “magazine” after a magazine has been filled and the corresponding magazine emptied, all other processes occur in a relatively smooth continuous process. The Petri dishes are transported to a conveyor belt, which will be constructed so that as the Petri dish lid is temporarily lifted, the agar will be poured into the dish, the lid returned to the dish, and stored in the second magazine. From there, gentle gears, making room for the incoming dish, will constantly push up the dish. This has the potential for unwanted splash, but controlling the gear’s rotation can limit the occurrence. The second magazine may be redundant, but the conveyor belt requires resetting the dishes into a stacked form. Manufacturing seems simple, and the detachable agar will minimize clean up. However, because of the nature of the machine, some (simple) assembly may be required before use and/or careful handling of the device before placement.

##### Concept 2: Pivoting Arm Machine (P.A.M.)

The design of Concept 2 focuses on keeping the Petri dishes stationary while moving the agar dispensary device (the vice versa to Concept 1). Programming can be minimized if the dish disassembly and subsequent stacking process can be efficiently handled with the rotation of a cleverly designed gear. However, a preprogrammed path and railway set will probably have to be constructed if the agar solution cannot rotate from a single point, which could be cumbersome to manufacture. Easy to handle, place, operate, and clean – this particular machine will be the most ideal to give to the customer. Splash will be minimized.

##### Concept 3: The Claw

Focusing on the “mimic human behavior aspect”, this particular method will consist of a claw, picking up a plane of laid Petri dishes in specified user laid locations. Taking up the largest space, and being the most cumbersome to transport, this system could also be difficult to manufacture and will most likely fail to hit even 100 plates in an hour. Consisting of the fewest parts, this design has the potential to be the cheapest to manufacture and the easiest to clean.

#### Concept 4: Gumball

Predominantly a preliminary design, concept four is the most compact. Requiring a vertical line of petri dishes to be consistently fed into the machine, this design resembles a gumball machine that handles a single Petri dish sliding down and inserting agar in a rotating fashion. This design lacks a stacking method, so the machine will have to make sure there is a large amount of space available in the fume hood. Because of its compact design, this will be the most expensive to manufacture and the hardest to clean.

### 3.3.3 Final summary

WINNER: Concept 1 – Assembly Line

Contrary to popular emotional demand, Concept 1 reigned on top from the happiness matrix. From further review, it can be seen that this concept has plenty of significant advantages over the other designs. Requiring the least amount of programming, this design is the most adaptable, and will minimize errors. Being the most easy to clean, disassemble, and assemble, Assembly Line will be great for user design. Some alterations can be made to the current design to lower the overall height as well make it more portable by creating one flat base for the entire design. A few parts will be difficult to manufacture but overall will be better for functionality. Unlike Concept 2, 3, and 4 (whose ability to work is slightly in question) – Concept 1 is the most plausible. Assembly Line is also the safest design.

Where Concept 1 falls is its restacking process that could produce a stacking buildup. Unlike Concept 2 and 4, which is one piece, 1 could require some in-hood assembly.

Overall, Concept 1 is the best design. Being mostly on par, and often times exceeding estimated performance expectations of other designs, Concept 1 meets all customer requirements.

### 3.4 Proposed performance measures for the design

1. By the end of this project, the machine should have a user prompt that will run and fill 120 petri dishes of agar solution without interruption.
2. Realizing that no design is perfect, no more than 2 dishes per batch of 120 dishes should be unusable. Unusable includes bubbling, splashing, etc.
3. In order to be easily portable for the average consumer, the total weight of the project (not including the agar solution) should not exceed 30 lbs.
4. In order to be easily assembled, the final design must be assembled in three or less (main) parts.

### 3.5 Design constraints (include at least one example of each of the following)

Refer to presentation below (delete from final version of report). **Source:** "Product Design Constraints and Requirements", [web.ewu.edu/.../Design\\_Constraints.ppt](http://web.ewu.edu/.../Design_Constraints.ppt), Eastern Washington University.

AP opens and closes the Petri dishes after inserting agar solution.

AP needs to be able to stack number of Petri dishes.

AP fills Petri dishes from an ascending order.

AP needs to be able to fit within the dimensions of the fume hood.

AP uses some form of sanitization to prevent foreign particles from getting into the agar Petri dishes before and after use.

AP needs to keep the agar solution well heated from the range of 60-70° C, to prevent the agar solution from producing bubbles.

AP must support 15mm x 100 mm Petri dishes.

AP must minimize the effect of splashing and sloshing while inserting the solution into the Petri dishes.

AP uses some form of computer regulation to control the rate of agar Petri dishes completed.

AP should be able to fill 120 plates while the agar is still heated with 4 liters of agar solution.

AP should receive its power through a wall outlet.

AP should require little assembly and packing.

AP cost should be reasonable.

AP must be made in a reasonable amount of time.

AP has a reservoir that can hold 4 liters of agar solution.

AP mimics human behavior.



Design\_Constraints  
.ppt

#### 3.5.1 Functional

The plate pouring device must have the proper dimensions to fit into the fumehood. This means that one of the constraints had to be the overall geometry of the entire device. Another constraint would be

the device had to incorporate some computer operation to control the amount of agar solution being poured into the petri dishes.

### 3.5.2 Safety

One of the constraints would be the device would have to be sterile before each use, which meant that the device would have to be easy to clean after use. This affected the choice of material used to make the structural components of the design. An environmental constraint would be that the plate pouring device would have to be able to be functional in a fumehood. Another constraint would be that the design had to prevent contamination of the agar solution from occurring while keeping the agar solution between a certain temperature range.

### 3.5.3 Quality

One of the important quality constraint would be that the device must be made out of material that is used for industrial grade material such that it be used for long durations of time. Another constraint is the ability for the device to use well tubing to prevent clogging of agar solution after repeated use for long periods of time. A third constraint under quality is that the device must meet the STLCC BioBench's lab protocol and standards. A fourth constraint is that the device must be able to have a large degree of reliability and a minimal chance of failure.

### 3.5.4 Manufacturing

A manufacturing constraint is that the device must be made out of a material that is easily to machine. Another constraint is that the device must be easily to be assembled out of the box. The third manufacturing constraint is having the inability of welding due to the usage of galvanized steel.

### 3.5.5 Timing

One of the timing constraint was the device must be constructed in a time period of 2 months. In of those two months, another time constraint would be the device must be at least halfway built by the initial prototype demonstration. The third time constraint is the part vendors' shipping time of components needed for the project.

### 3.5.6 Economic

The economical constraint was that the device would have to be built on a budget of \$400. Another economical constraint is the limited usage of certain supply vendors verified on the preferred list.

### 3.5.7 Ergonomic

One of the ergonomic constraints was that the device had to be easy to move for assembly and disassembly.

### 3.5.8 Ecological

One of the ecological constraint was that the material selection of the device had to be resistant to toxicity and flammability, since it is in a scientific environment.

### 3.5.9 Aesthetic

One of the aesthetic constraint was the device would be symmetric about the point of the conveyor belt.

### 3.5.10 Life cycle

One of the life cycle constraint was the device must be able to used repeatedly after many uses. Another constraint was the device had to be easily recycle if the device went out of commission.

### 3.5.11 Legal

The legal constraint is the device must be different enough to prevent infringement of the rights of the patents used to help establish initial concepts during the design process.



## 4 Embodiment and fabrication plan

### 4.1 Embodiment drawing

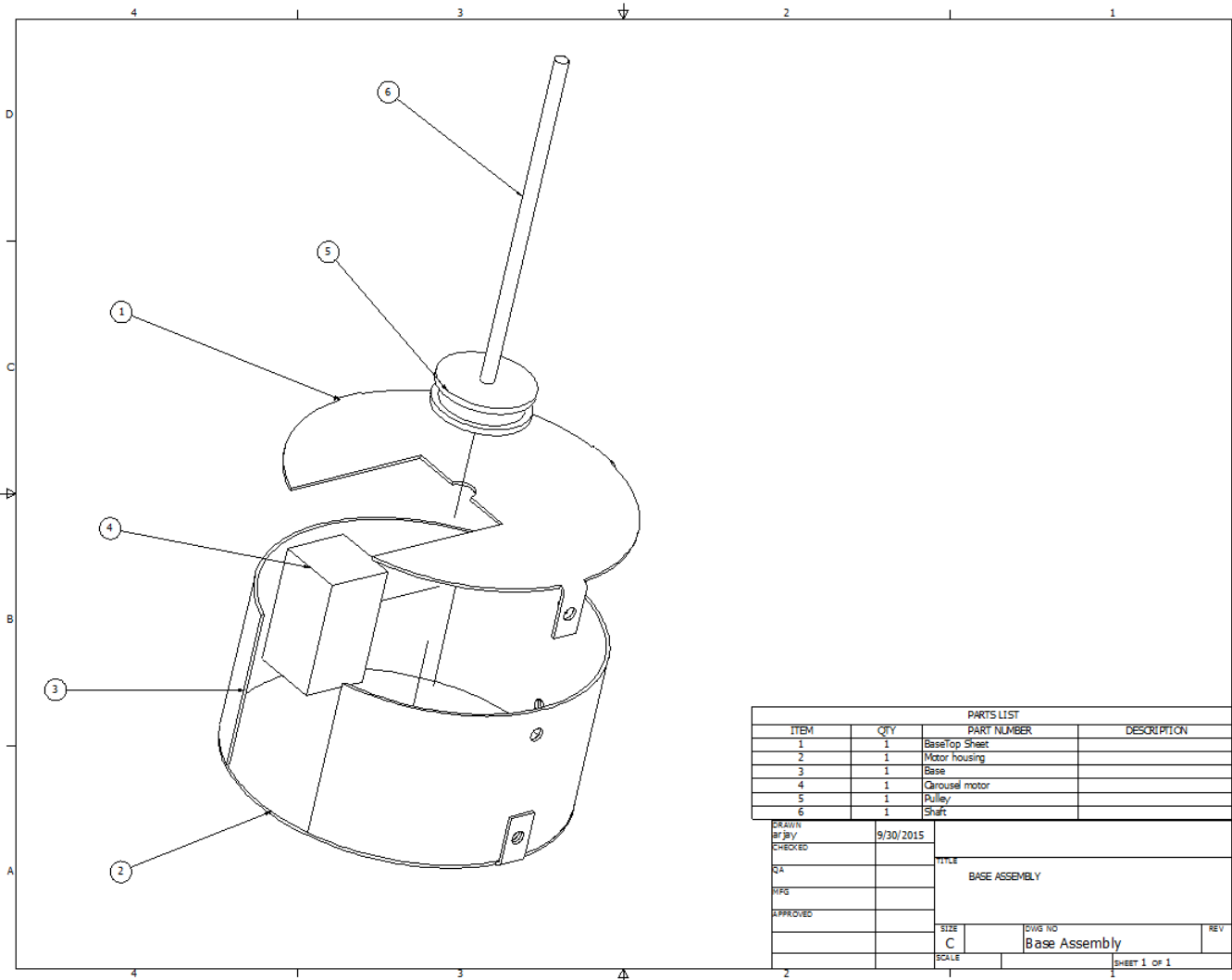

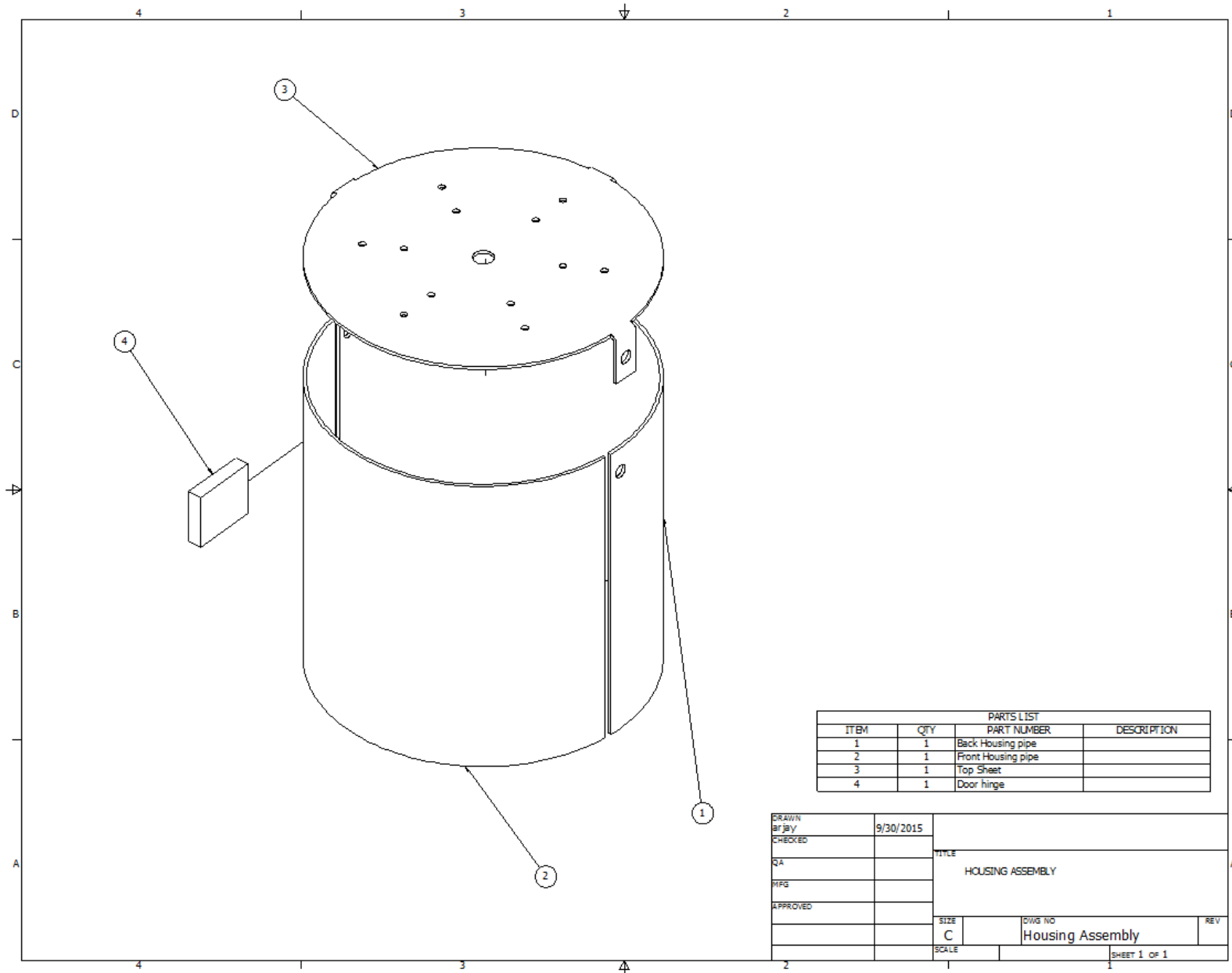

PARTS LIST			
ITEM	QTY	PART NUMBER	DESCRIPTION
1	1		Back Housing pipe
2	1		Front Housing pipe
3	1		Top Sheet
4	1		Door hinge

DRAWN	9/30/2015	TITLE	
CHECKED		HOUSING ASSEMBLY	
QA		SIZE	DWG NO
MFG		C	Housing Assembly
APPROVED		SCALE	REV
			SHEET 1 OF 1

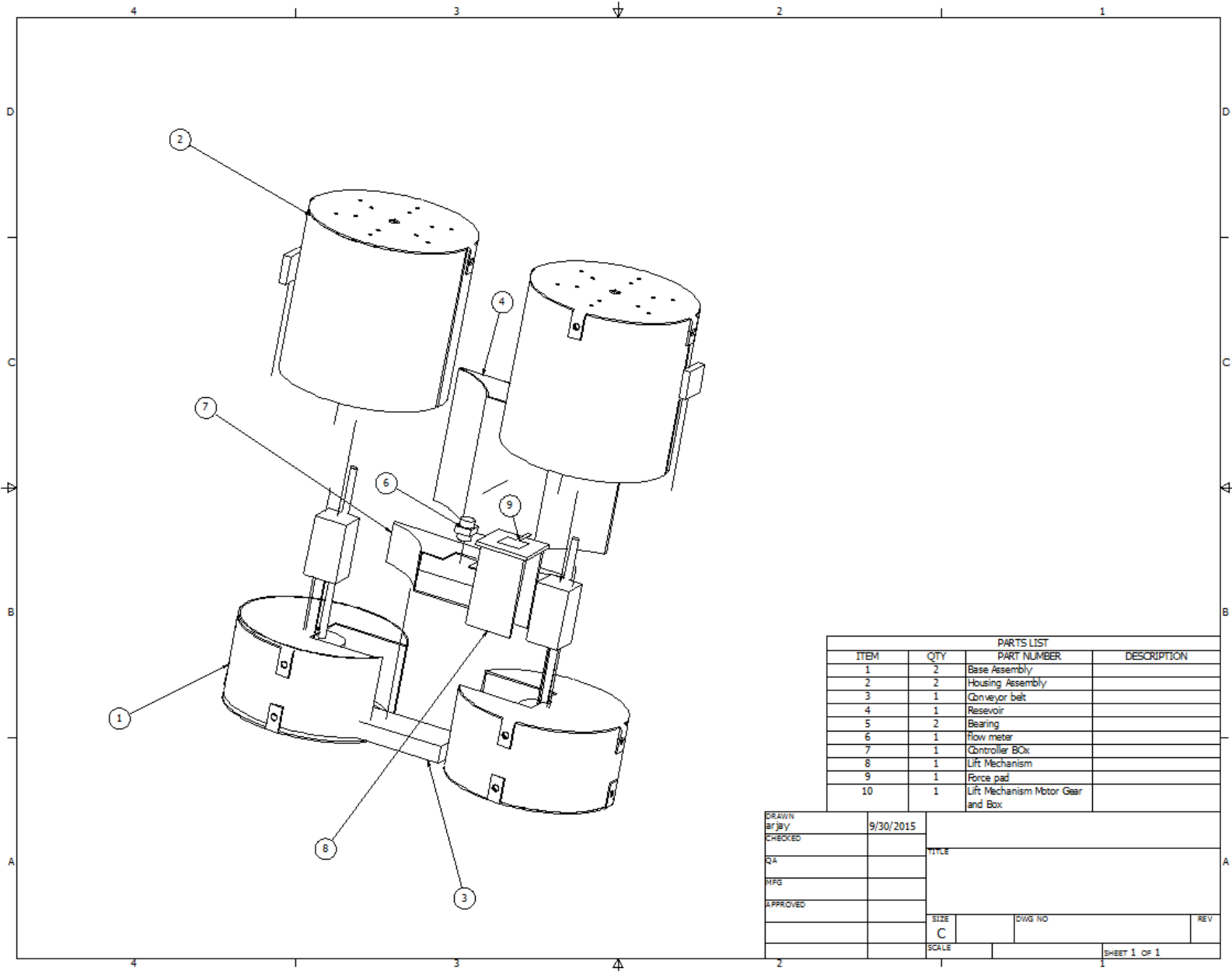

PARTS LIST			
ITEM	QTY	PART NUMBER	DESCRIPTION
1	2		Base Assembly
2	2		Housing Assembly
3	1		Conveyor belt
4	1		Reservoir
5	2		Bearing
6	1		Flow meter
7	1		Controller Box
8	1		Lift Mechanism
9	1		Force pad
10	1		Lift Mechanism Motor Gear and Box

DRAWN BY	9/30/2015	TITLE	
CHECKED		REV	
QA		SIZE	DWG NO
MFG		C	
APPROVED		SCALE	SHEET 1 OF 1

## 4.2 Initial Parts List

Part	Use	Manufacturer	Catalog Number	Quantity	Price per Quantity (\$)	Total Price
12" x 60" Galvanized Round Sheet Metal Pipe	Back Housing Semi Cylinder, Front Housing Semi Cylinder	Home Depot	SM-3060GR 12	1	23.17	23.17
¼" x 12 x 12 Plain Steel Plate	Base Top, Base, Tower Base, Tower Top, Pulley	Home Depot	800497	5	9.87	49.35
3" x 3" x ¼" Sheet Metal	Pulley	McMaster Carr	1388K402	1	20.82	20.82
12" x 6' Multipurpose 6061 Aluminum Rod	Rods	McMaster Carr	8974K28	4	15.34	76.70
½" x 3' Multipurpose 6061 Aluminum Rod	Shaft	McMaster Carr	8974K28	1	8.44	8.44
½" x ¼" x 7/16" Nylon Bearings	Housing Bearings	McMaster Carr	6389K233	4	1.56	6.24
Force Sensitive Resistor - Square	Force Sensor	Sparkfun	SEN-09376	2	7.95	15.90
Flat-Belt Idler Pulley with Ball Bearings	Pulley	McMaster Carr	6235K11	2	13.88	27.76
G ¼ Water Flow Sensor	Piping	GarageLab	SEN02141B	1	13.90	13.90

DC Motor 1/8 HP 24VDC	Pulley	AutomationDirect	MTPM-P13-1JK42	1	77.00	77.00
Surface-Mount Hinge	Housing Lock	McMaster Carr	1635A24	2	3.50	7.00
Infrared Proximity Sensor	Sensors	GarageLab	GP2Y0A21YK0F	2	13.95	27.90
Pinch-Style Aluminum Solenoid Valve for Tubing	Piping	McMaster Carr	5431T121	1	147.87	147.87
1100 Series Miniature Belt Conveyors	Belt Conveyor	Dorner Conveyors	TBD	1	TBD	TBD
Plastic	Reservoir, Controller Box	3-D Printed	N/A	N/A	N/A	N/A
¾" x 5' Flexible Standard-Wall Clear PVC Unthreaded Pipe	Piping	McMaster Carr	4805K52	1	15.98	15.98
Arduino Starter Kit	Controller	Arduino	K000007	1	89.52	89.52
						<b>651.05</b>

4.3 Draft detail drawings for each manufactured part

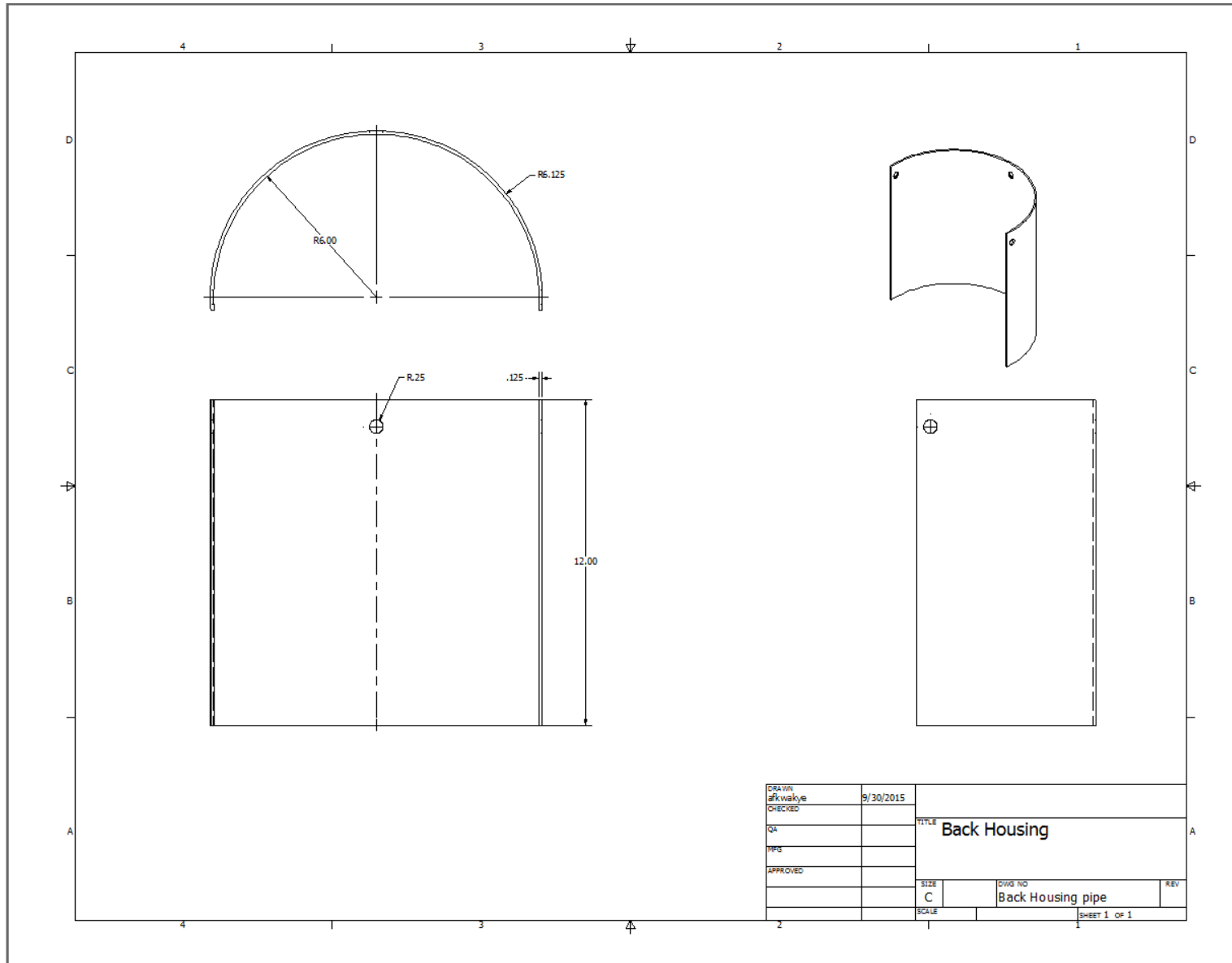

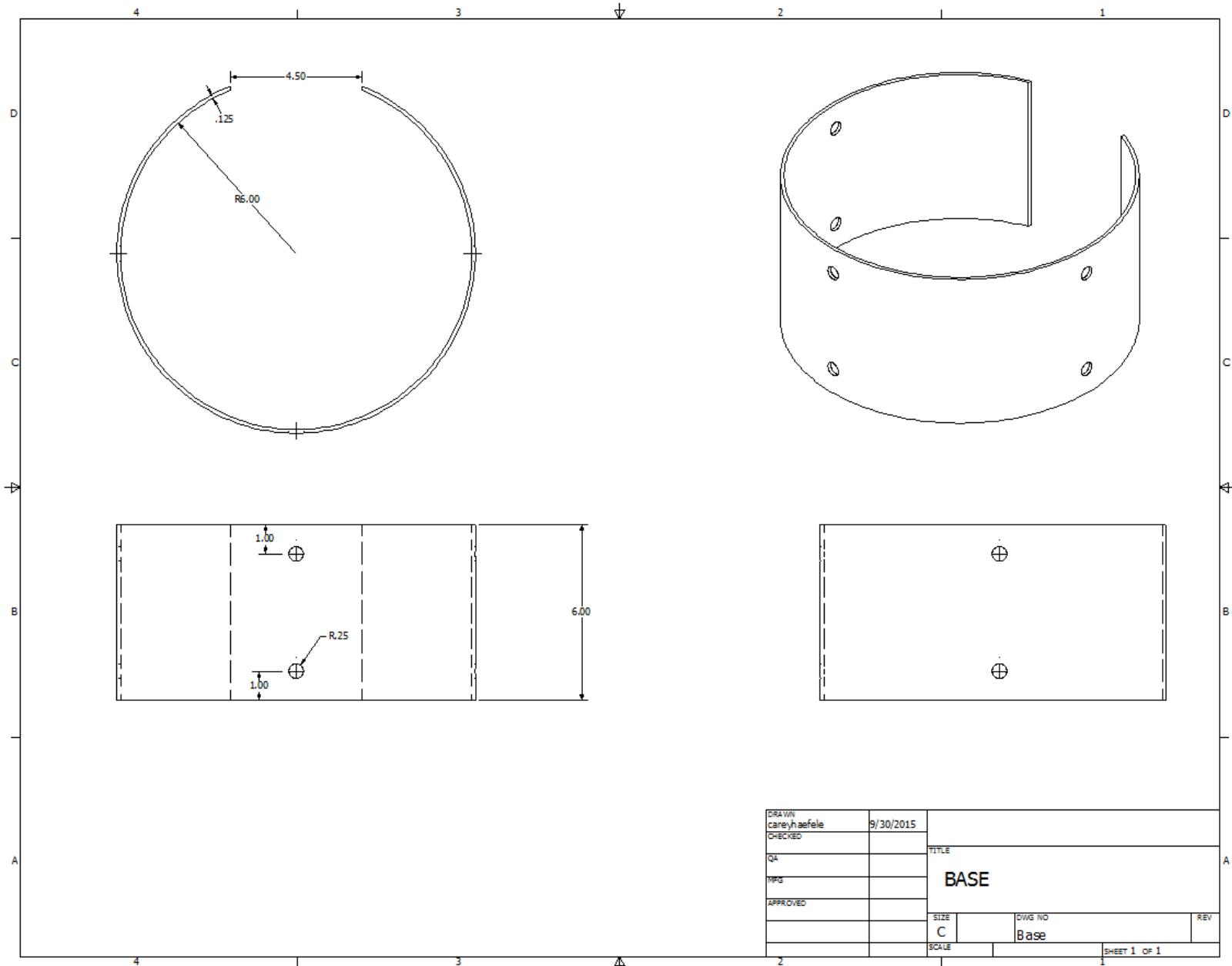

DRAWN carey/haefele	9/30/2015		
CHECKED		TITLE	
QA		<b>BASE</b>	
TPO		SIZE	DWG NO
APPROVED		C	Base
		SCALE	REV
			1
			SHEET 1 OF 1

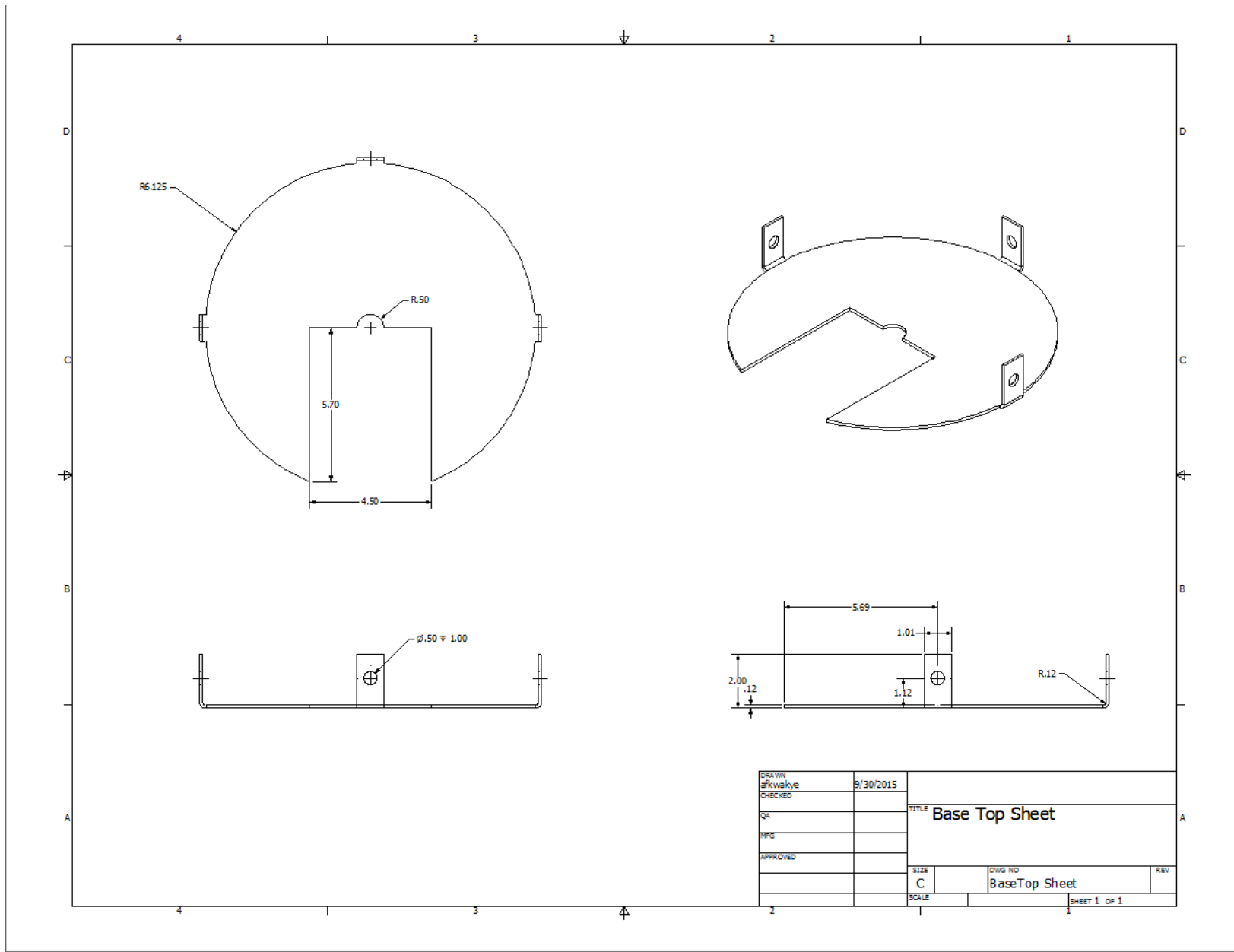



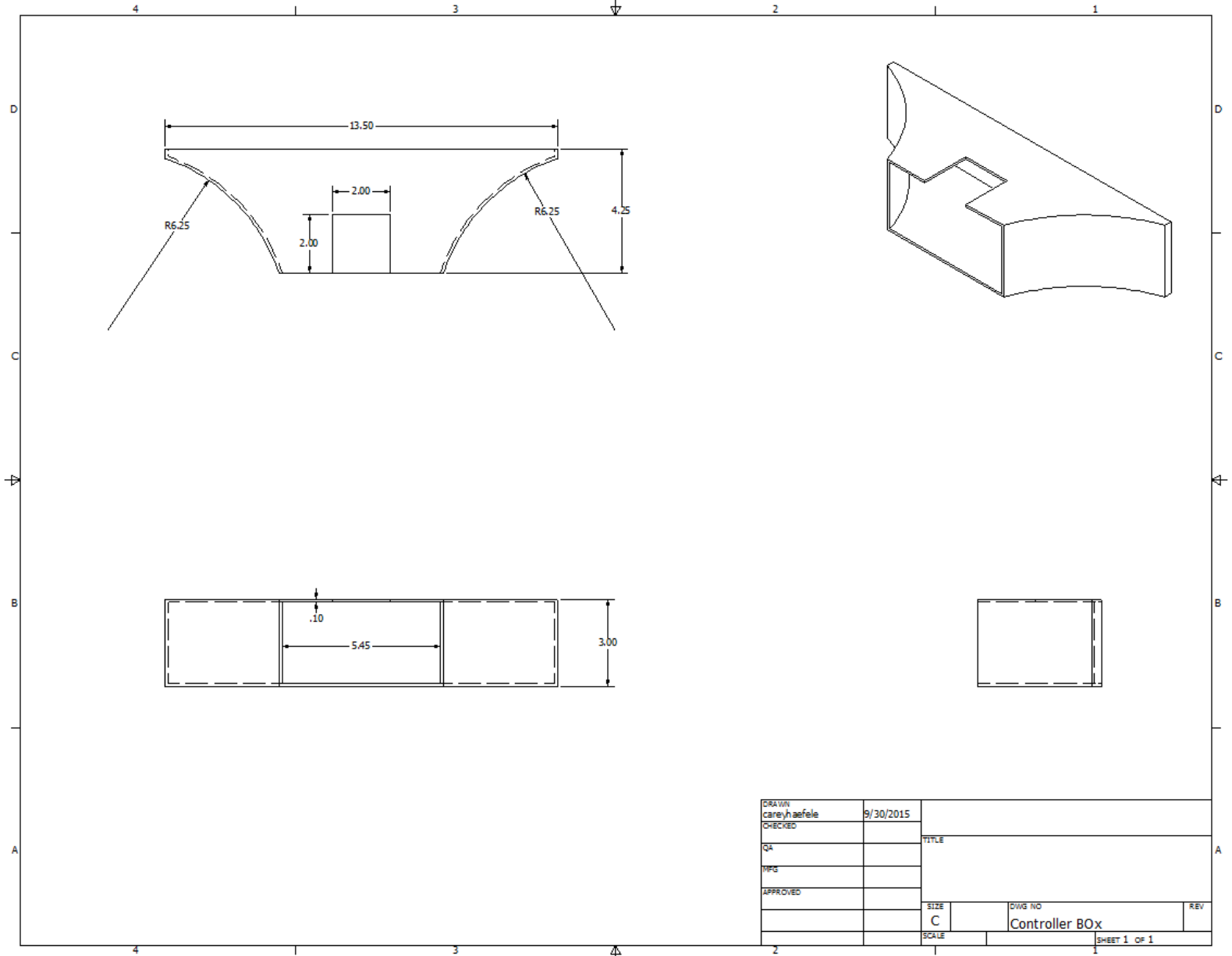

DRAWN carey/aefefe	9/30/2015	TITLE	
CHECKED		REV	
QA		REV	
MFG		REV	
APPROVED		REV	
		SIZE C	DWG NO Controller B0x
		SCALE	SHEET 1 OF 1

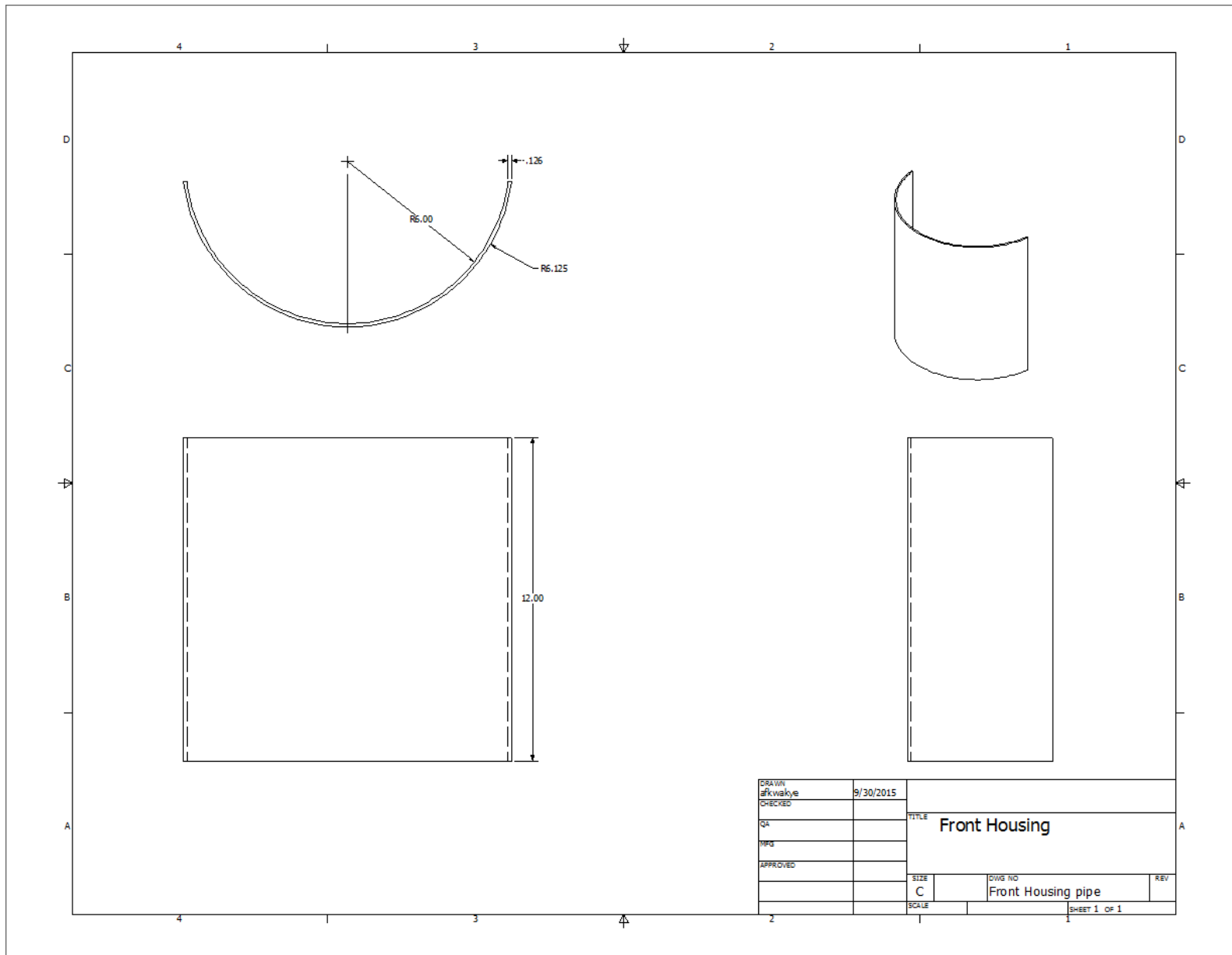

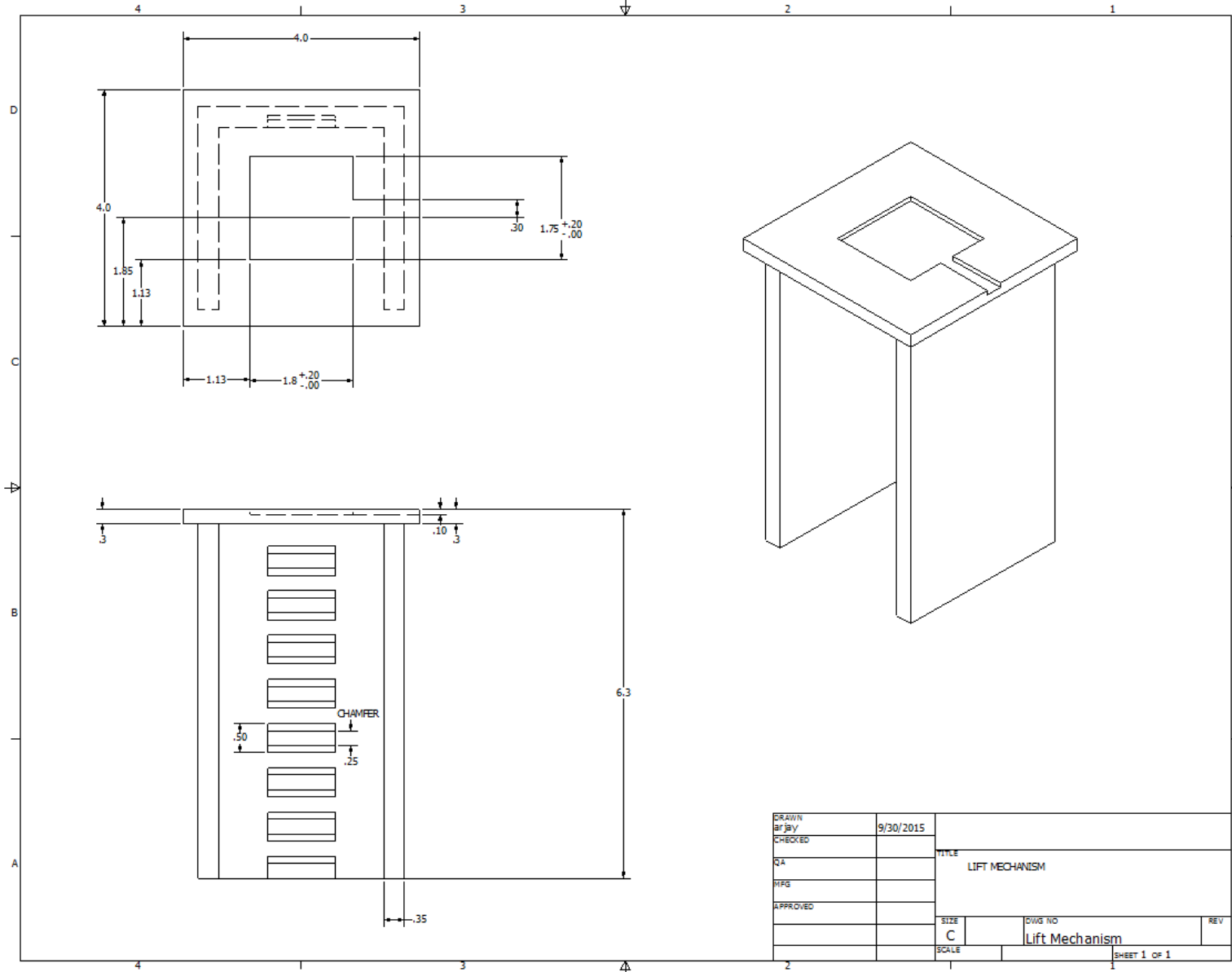

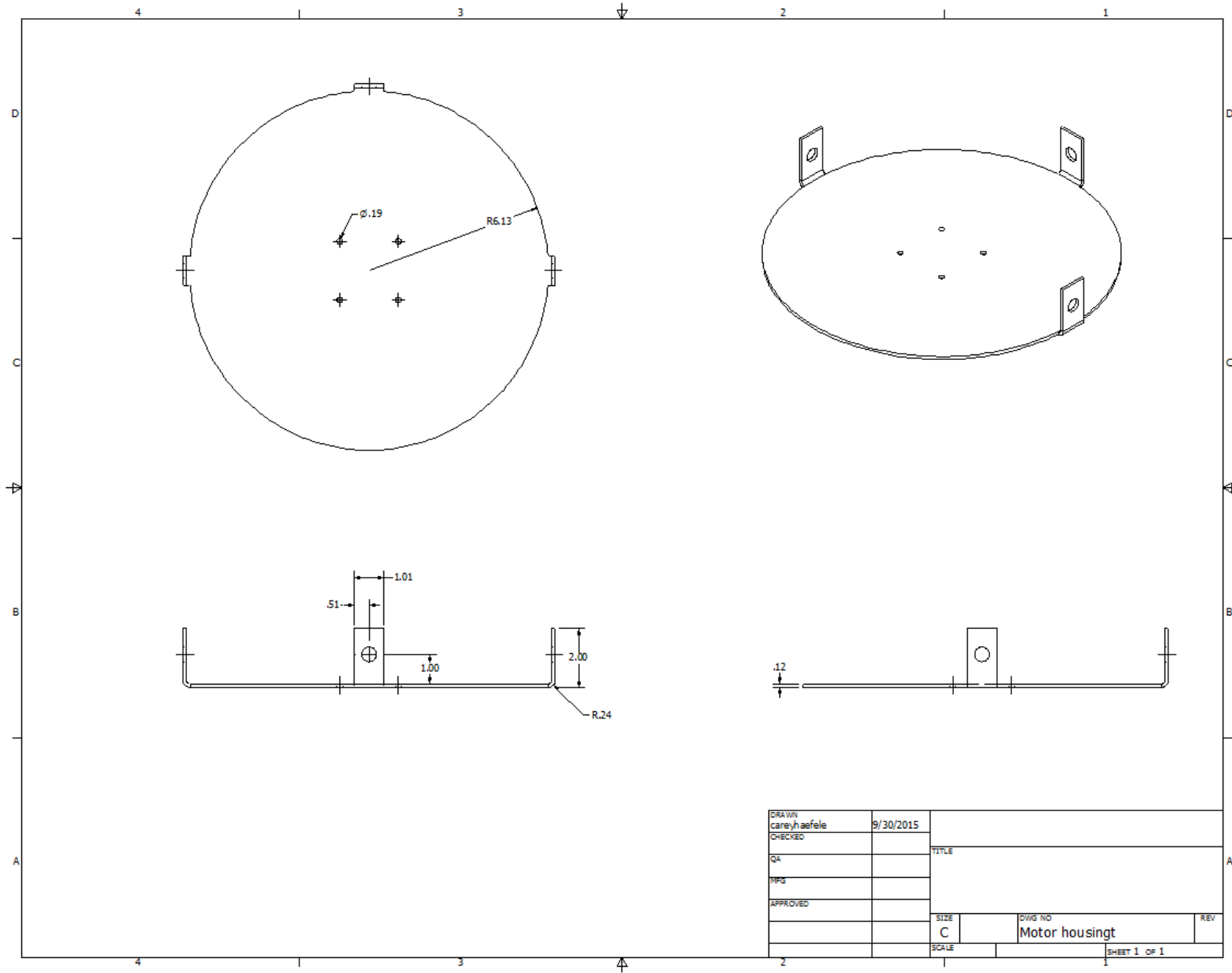

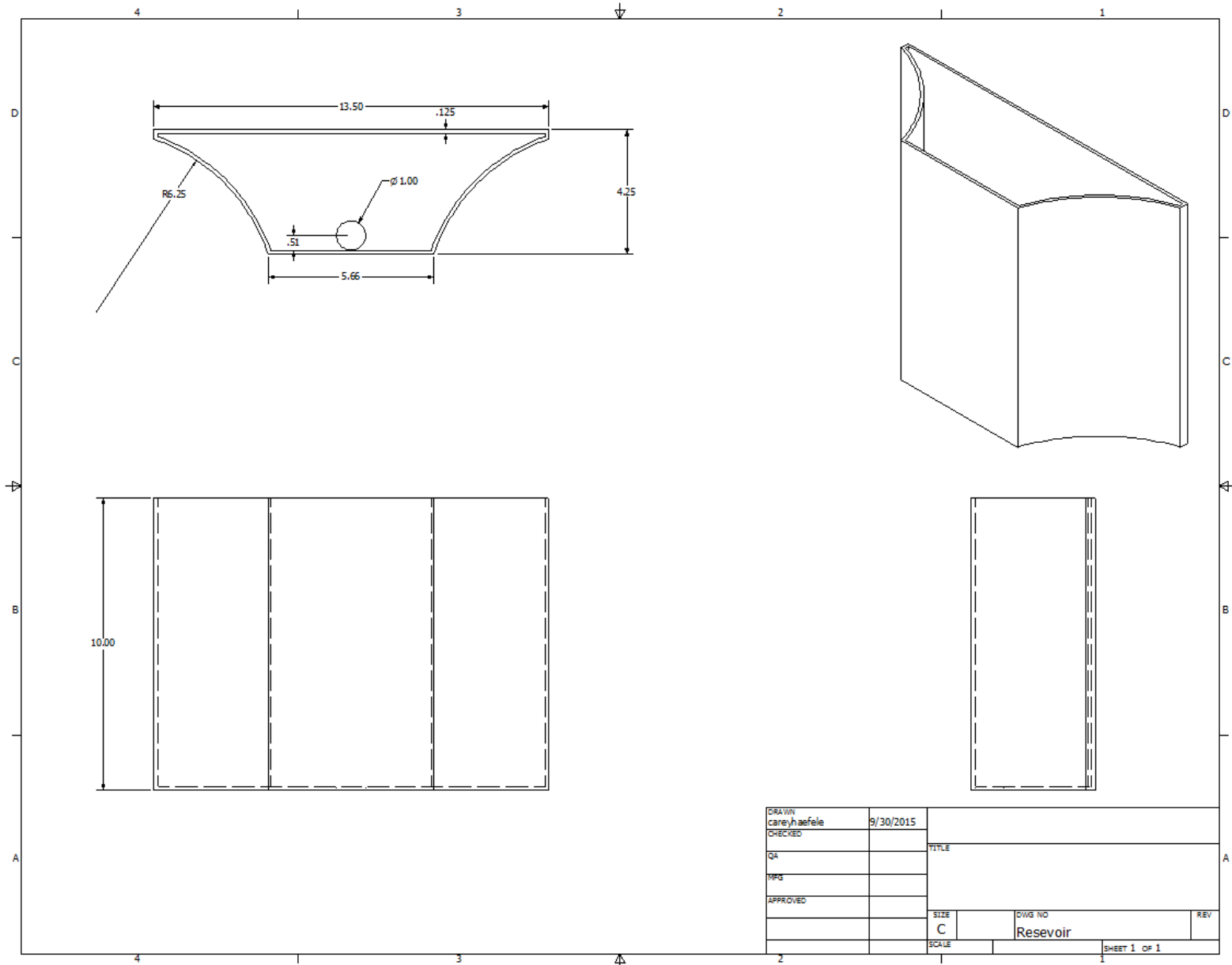

DRAWN	careyhaefele	9/30/2015		
CHECKED			TITLE	
QA				
MFG				
APPROVED				
			SIZE	DWG NO
			C	Reservoir
			SCALE	REV
				SHEET 1 OF 1

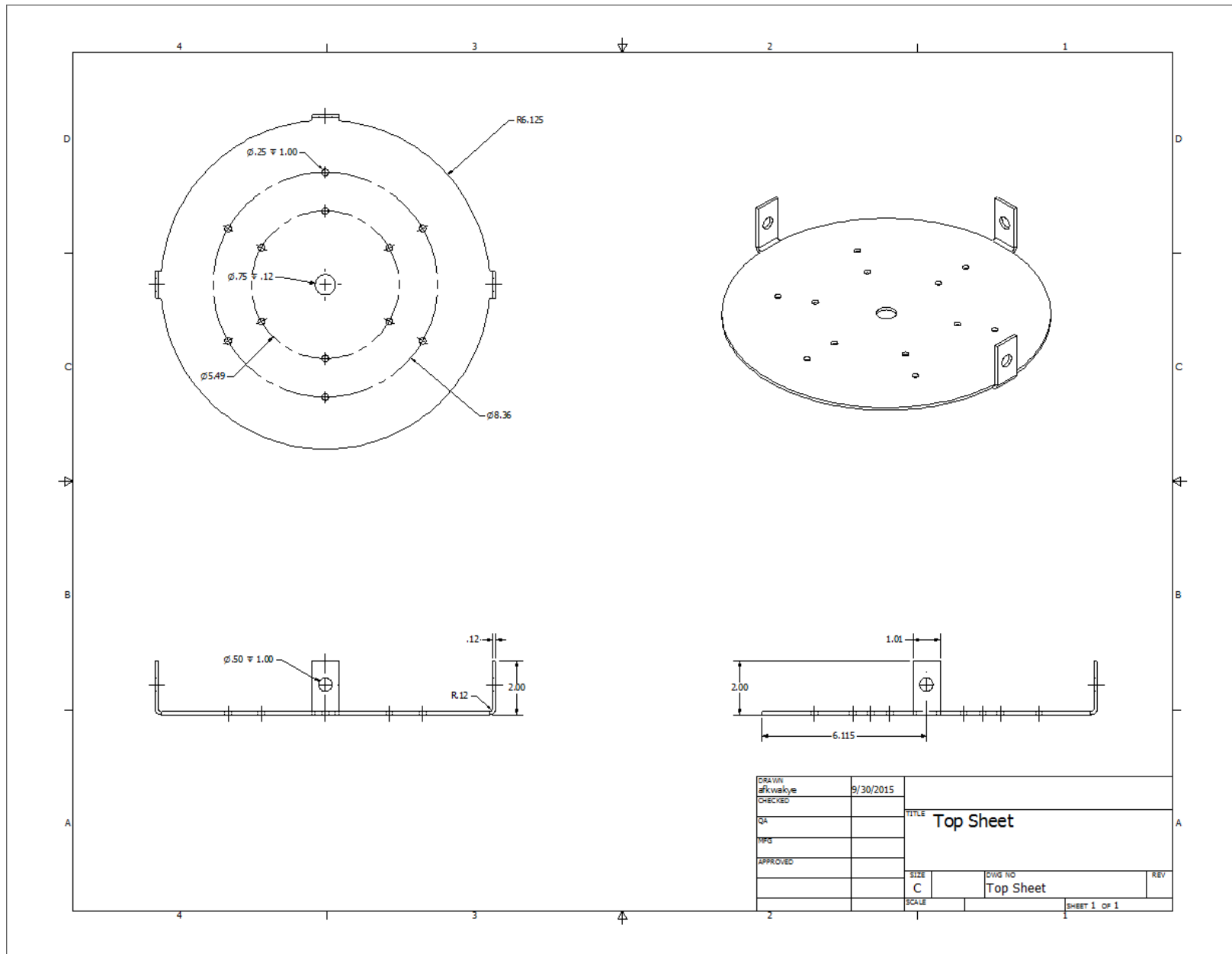

#### 4.4 Description of the design rationale for the choice/size/shape of each part

**Back Housing Semi Cylinder-**This part will represent one of the halves on both cylinders on the agar pouring machine. The height is 12 in. because it was designed to hold 20 petri dishes at each slot. There are  $\frac{1}{2}$ " holes placed on the top to connect the back housing to the top sheet. This back housing is supposed to be made with the 12" in. x 60" in. galvanized steel that cost \$23.17. The diameter of the housing cylinder is  $12\frac{1}{4}$ " in. because the housing needs to hold 6 columns of 20 petri dishes each.

**Base Cylinder-** The base was made to house the pulley and motor system below each of the housing cylinders. This part is made with the  $\frac{1}{4}$ " in. x 12" in. x 12" in. Plain Sheet Steel Plate that cost \$49.35. The height of 6 in. was necessary to house both the DC motor and the pulley system. The base cylinder in the storage cylinder side will hold the DC motor. The diameter of the base cylinder is  $12\frac{1}{4}$ " in. because it needs to match up with the housing cylinder's diameter to look as one cohesive unit and provide space for the pulley. There are also  $\frac{1}{4}$ " in. holes placed on the top and bottom of the base cylinder for connecting the base cylinder to both the top base cover and bottom base.

**Base Top Sheet-** The base top sheet is being used to cover the each of the base cylinders. It will also be contact with the housing cylinder, since the housing cylinder is sitting on top of the base top cover. This made will also be made with the  $\frac{1}{4}$ " x 12" in. x 12" in. Plain Sheet Steel Plate that cost \$49.35. The diameter of the top cover was  $12\frac{1}{4}$ " so that the cover would properly fit on top of the base cylinder. The holes are also  $\frac{1}{4}$ " in. holes to connect the base top with the base cylinder. There is also a cut out of 1" in. hole for the pulley shaft to reach the top of the housing cylinder. The other cutout of  $5\frac{7}{10}$ " in. x  $4\frac{1}{2}$ " in. is for spacing to properly place the DC motor and pulley into the base cylinder.

**Bearing-** The bearing is the component that properly aligns the main shaft running from the pulley to the top of the housing cylinder for each side. It is placed on the cover of each housing cylinder. We decided to use  $\frac{1}{2}$ " in. x  $\frac{3}{4}$ " in. x  $\frac{7}{16}$ " in. Nylon Bearings that cost \$6.24 because it matched the diameter of the main shaft and be forced fitted onto the cover of the housing cylinders.

**Controller Box-** This component will house the Arduino microprocessor underneath the reservoir. It will also be created through 3-D printing.

**Conveyor Belt-** This is one of the most important parts of the design. The conveyor belt is to carry petri dishes from the storage cylinder to the housing cylinder while stopping by filling nozzle to fill the petri dishes with the agar solution. Thus, it was important to find the right size of the conveyor belt. We decided to go with the 1100 Series Miniature Belt Conveyors from Dormer Conveyors because it best matched the length we needed. The price is unknown at the moment because we are waiting back for a quote from Dormer.

**Door Hinge-** This component is being used to securely connect the 2 halves of the housing and storage cylinders. This also allows for the halves to easily pivot to allow for easy installation of the petri dishes. We decided to use Surface-Mount Hinge that cost \$7.00.

Flow Meter Sensor- This component is being used to determine the flowrate of the agar solution. It will be used in determining the shutting and closing of the pinch valve controlled by the Arduino. The sensor will be placed into the reservoir. We decided to use the G  $\frac{3}{4}$ " in. Water Flow Sensor for \$13.90.

Force Pad- This component will be sitting on top of the lift mechanism inside the region of the housing cylinder. It will be connected to the Arduino and be held responsible with the determination of when the lift needs to lift the petri dish into the proper housing slot. We decided to go with the Force Sensitive Resistor – Square that cost \$15.90, but also thought of an alternative approach. If the force sensor does not properly meet the standards we like, we have the backup of Infrared Proximity Sensors that cost \$27.90, which would recognize whenever a petri dish was at the end of the conveyor belt.

Back Housing Semi Cylinder -The component is being used as the other half of the cylinders. This part of the cylinder rotates on the door hinge, which allows the cylinder to easily be accessed. We decided to build this using the  $\frac{1}{4}$ " x 12 x 12 in. Plain Steel Plate for \$49.35.

Arduino Microprocessor- This component will control the every operation of the agar pouring machine through the perspective of the sensors. It will be housed in this own boxing underneath the reservoir. We decided to go with the Starter Kit to make sure we have most of parts we will need to operate the microprocessor, which will cost \$89.52.

Pulley- This component will drive both shafts of the housing and storage cylinders, causing both cylinders to move at the same time. In order to build the pulley, we decided to use  $\frac{1}{4}$ " in. x 12 in. x 12 in. Plain Steel Plate (\$49.35), 3" in. x 3" in. x  $\frac{3}{4}$ " in. Sheet Metal (\$20.82), and Flat-Belt Idler Pulley with Ball Bearings (\$27.76). The outer diameter of the pulley is 3  $\frac{1}{2}$ " in., while the inner diameter is 3 in.

Pulley Motor- The component will control the shafts on the pulleys. We decided to use DC Motor 1/8 HP 24VDC because this motor would provide the proper power to drive the pulley.

Reservoir- This component will store the agar solution. We decided to build this piece through 3-D printing. The reservoir is made to hold 4 liters of the agar solution. It will also be treated with some resin to prevent the agar solution from sticking to the reservoir, which will ease the cleaning of the reservoir.

Rods-This component will be used to establish the slots to store the petri dishes in the housing and storage housings. We decided to use 12" in. x 6' ft. Multipurpose 6061 Aluminum Rod, which cost \$76.70. The diameter of the shaft is  $\frac{1}{4}$ " in. and the length is 6 in. Each petri dishes column will be supported by 4 rods.

Shaft-This component will be connected with the pulley to rotate the cylinders to change the stack of petri dish columns being operated on. We decided to use  $\frac{1}{2}$ " in. x 3' ft. Multipurpose 6061 Aluminum Rod, which cost \$8.44, because the diameter we designed for the shaft is  $\frac{1}{2}$ " in.

Top Sheet- This component will be on top of the housing cylinder. The bearing will be forced fitted into the top sheet. There are 3 holes of  $\frac{1}{2}$ " in. to connect the top cover with the sides of the cylinders. There is 1 hole of  $\frac{3}{4}$ " in. for the bearing to align the shaft. Finally, there are 12 holes of  $\frac{1}{4}$ " in. for the rods to fit into. We decided to use  $\frac{1}{4}$ " x 12 x 12 Plain Steel Plate with the cost of \$49.35.



### 4.5 Gantt chart

#### MEMS 411 Senior Project

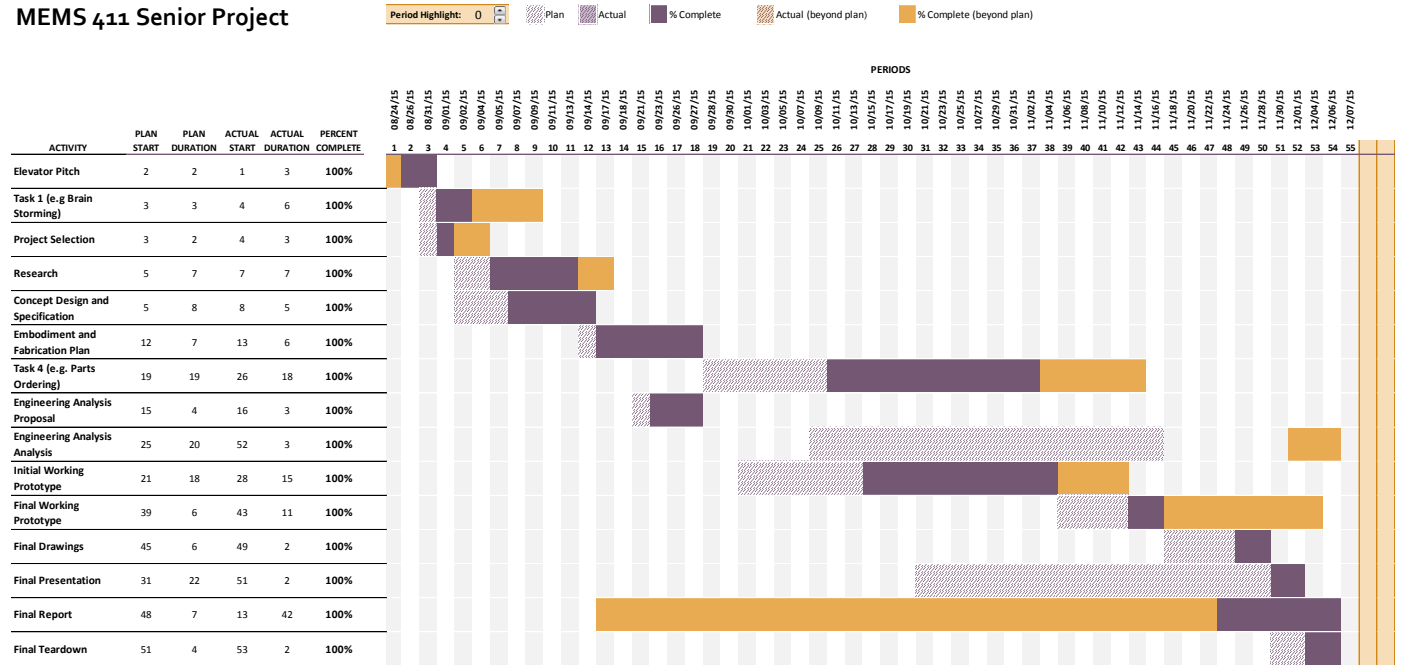

A larger view of the Gantt chart can be viewed through the following Excel file.



MEMS 411 Gantt Chart(1).xlsx

## 5 Engineering analysis

### 5.1 Engineering analysis proposal

#### 5.1.1 A form, signed by your section instructor (insert your form here)

#### **ANALYSIS TASKS AGREEMENT**

PROJECT: \_\_Agar Plate Pouring IV\_NAMES: \_\_Carey Haeefele\_\_INSTRUCTOR: \_Mary Malast\_

\_Alexander Kwakye\_

\_Arjay Parhar\_

The following engineering analysis tasks will be performed:

1. Determine the thickness of the base to support the housings
2. Horsepower of motor to rotate the shafts on the housings
3. Support strength of reservoir base
4. Horsepower of lifter
5. Angle of incline, space needed, length of lid opening rail
6. Fin thickness for separating plate column

We also plan to test the lift mechanism first. Afterwards, we will evaluate the support structures of the housing and then reservoir. Lastly, we will test the horsepower of the motor rotating the housing.

The work will be divided among the group members in the following way:

Alex- 1,3

Carey-2,4

Arjay-5,6

Instructor signature: \_\_AK, CH, AP\_; Print instructor name: \_\_\_\_\_

(Group members should initial near their name above.)



Engineering  
Analysis Proposal.pc

## 5.2 Engineering analysis results

### 5.2.1 Motivation. Describe why/how the before analysis is the most important thing to study at this time. How does it facilitate carrying the project forward?

The before analysis was the most important thing because it was the determining factor behind material selection and deciding part ordering. The before analysis allows the project to have some minimal specifications that need to be met. With those minimal specifications, the group can order the right parts with the understanding that such parts will suffice for the initial prototype. The before engineering analysis also gives the team a chance to make some final alternations to the engineering design.

In terms of this project, it served more as a structural verification to insure all of the static and moving parts of the plate pouring device was adequate in theory. The before analysis determined the thickness of the base to support the housings, the amount of horsepower the stepper motors needed to rotate the shafts on the housings, material need to support the strength of the reservoir base, the dimensions (ie. angle of incline, space needed, length, etc.) of lid opening rail, and the fin thickness for separating plate columns in the housings. With these following specifications known, it will give the group a further detailed design of the plate pouring device that can be used as a guide while constructing the initial prototype.

### 5.2.2 Summary statement of analysis done. Summarize, with some type of readable graphic, the engineering analysis done and the relevant engineering equations

#### **Determine the thickness of the base to support the housings**

Because each of the motor housing structures consist of a top and bottom plate, we decided to partition the weight of the housing components between the two plates. The bottom plate of the base structure supported the shaft, carousel motor powering the shafts, the side components of the housing, and the pulley. The top plate of the base, supported the petri dishes. Because most of the weight will heavily depend on the strength of the bottom plate, we decided to focus the analysis primarily on the bottom plate. The plan to determine the thickness of the base was by using the modified version of the bending moment using the maximum deflection  $v_{\max}$  to represent the deflection. The following equation is the modified bending equation used.

$$t = \frac{-125F^2L^4}{384EvA} * \frac{2}{m}$$

$t$  is the thickness of the base plate,  $F$  is the amount of force applied axially to the base plate [N],  $L$  is the diameter of the base plate [m],  $E$  is the Young's modulus of the base plate [Pa],  $\nu_{\max}$  is the Poisson's ratio of the base plate,  $m$  is the mass of the base plate [kg].

We used the assumption of the pulley, shaft, and most of the structural components were being made from cold drawn low-carbon steel from McMaster Carr. The plates were made from plain steel with the Young modulus being 200 GPa and Poisson's ratio of 0.305.

Addition: The pulley system was rejected because it would interfere with the best path of travel for the petri dishes. Instead, stepper motors were placed into both tower bases and would spin based on the same input signal. This did not change the size of the plates used because the parts were already purchased and the weight was reduced making the parts still viable for support.

### Horsepower of motor to rotate the shafts on the housings

The horsepower of the motor that moves the entire upper assembly of both of the housing towers will be the largest motor necessary. It has to rotate the device separating the dish columns, and the shaft for both sides as well as the pulley system and all the 120 petri dishes placed into the machine. The largest weight it will have to move is after the plates have been half filled with agar.

The minimum motor power will be found by using CADD to create the parts. Since some of the parts are of unusual shape this will save time. The objects are then changed to the desired material and the weight of them is measured using the properties menu in Autodesk Inventor. Using the density of agar and the approximate amount of 30 mL in each filled plate the weight of petri dishes can be found. The weights are then added together.

$$F_g = \sum Weights$$

Based on the CADD drawing it can be shown that the center of mass of all the parts are along the same axis of rotation. So the amount of torque the motor will have to produce can be found by multiplying the weight of the part by the distance its maximum radii away from the axis. This will be an over approximation of the torque necessary for the motor as a means to make sure it performs at least at the speed desired.

$$T = \sum Weight \times R_{max}$$

Once the torque is determined we know we want it to rotate between petri dish columns in at least 2 seconds. Therefore angular velocity is  $\pi/6$  [rad/s]. The torque is then multiplied by the angular velocity to provide an answer in [ft\*lbs/s] which can be converted to horsepower.

$$P = T \times \omega$$

$$550 \left[ \frac{ft \times lbs}{s} \right] = 1[hp]$$

**The horsepower necessary for the lifter device was determined in a similar way.**

Addition: The pulley system was rejected so the motor only has to spin one petri dish housing instead of both. The mass was recalculated and placed into the same system stated above. The power of the motors was adjusted and purchased without complication.

**Support strength of reservoir base**

To determine the support strength of the reservoir base, we went under the assumption of the reservoir being made from ABS plastics with the Young's modulus of 1.4 GPa. Another assumption that was used was that the reservoir would hold 4 liters of water and 92 grams of agar solution. The following deflection equation will be used to determine the strength of the reservoir base.

$$v_{max} = \frac{-5wL^4}{384EI}$$

Addition: The 3D printer available did not support the size of parts desired for the reservoir base. The base was changed to steel since leftover material was available. The calculations were adjusted for the new material properties.

**Angle of incline, space needed, length of lid opening rail**

The lid opening rail needs to be constructed in a way that minimizes the distance the top petri dish will be separated from the bottom petri dish just long enough for the agar to be poured. Factors that complicate this process include the agar pouring angle, dimensions of each half of the petri dish, friction, conveyor belt speed, and remaining contact surface area when top half of the petri dish is elevated. Due to the multitude of interdependent factors, the simplest solution will be to build a couple of prototype ramps to determine the angle of incline, space needed, and length of the lid opening rail through a trial and error process. First, our team will find the maximum height that the petri dish can sustain. From there, we will put in a set of trials to determine the optimal angle. Then, using basic trigonometry, we will determine the angle from  $\frac{Height_{maximum}}{\tan(angle\ of\ incline)} = Length$

**Fin thickness for separating plate column**

The internal housing containing the petri dishes will be 3-D printed. Dubbed the "Fan", three intersecting fins of a determined thickness will be printed. Said thickness must be able to support the internal movement of the petri dishes without fracture and with minimal bending. Estimating the following values: angular speed ( $\pi/6$  rad/s), petri dish contact area, contact location, safety factor (1.5), and through values taken from an online source detailing the properties of ABS (Acrylonitrile butadiene styrene) – it was determined that a fin thickness greater than 0.04643 in is needed. At the programmed thickness of 0.25 in, we far exceed design requirements.

Addition: The design was modified to have five stacks of dishes instead of six since it better accommodated the stepper motors. The weight acting on the fins was then adjusted and the size needed was recalculated, but the size initially determined was still satisfactory for the design.

### **5.2.3 Methodology. How, exactly, did you get the analysis done? Was any experimentation required? Did you have to build any type of test rig? Was computation used?**

The analysis was done based on computation done using the various equations mentioned in the sections above. There was no test rig built to calculate the analysis.

### **5.2.4 Results. What are the results of your analysis study? Do the results make sense?**

#### **Determine the thickness of the base to support the housings**

The thickness of the base to support the housings were around 1.7561 in. The results does make sense because there was a safety factor was also considered into the equation above, hence the reason why the thickness of the base was very large. In practice, does not make sense to use because the material used was steel and due to its tensile strength, at least .0625 inches is needed to support the housings.

#### **Horsepower of motor to rotate the shafts on the housings**

The horsepower of the motor need to rotate the shafts on the housings was  $7.29 \times 10^{-3}$  hp. The results made sense, which is the reason why a pack of stepper motors at least  $8 \times 10^{-3}$  hp were bought to drive that had a reasonable amount of the conveyor belt and the housings.

#### **Support strength of reservoir base**

The support strength of the reservoir base was .1006 psi with the thickness of the reservoir base being .008 in. This result made sense because the 4 liters of agar solution was around 8.8 lbs, and we knew would not yield to such force applied.

#### **Angle of incline, space needed, length of lid opening rail**

The angle of incline for the opening rail was  $30^\circ$  with a length of 8 in. This made sense because the angle of incline had to be more than  $0^\circ$  and less than  $45^\circ$  in order to pick up the plate's cover and close it back up after filling. If the angle was increased, it would reduce the length of opening rail needed to be in order to open up the dish's cover.

### **Fin thickness for separating plate column**

The thickness of the fins separating the plate column was .04643 in. This made sense because of the 12 in. diameter we were using for the bottom plate for each housing. If the thickness was increased, it would of affected the height of the housings in order to hold 120 plates.

#### **5.2.5 Significance. How will the results influence the final prototype? What dimensions and material choices will be affected? This should be shown with some type of revised embodiment drawing. Ideally, you would show a “before/after” analysis pair of embodiment drawings.**

Determine the thickness of the base to support the housings: The results influenced the minimum thickness we could allow for the base plate thicknesses to be. Since the size was so small the cost and availability of the stock material was a larger factor. We ended up going with a sheet steel that was purchased from a local establishment.

Horsepower of motor to rotate the shafts on the housings: The results greatly influenced the design. The motor dimensions were found by researching motors with the power necessary from the analysis. The size of the motors then changed the height of the housing base. The motors were also better suited for rotating in five steps rather than six so the fins were reset to accommodate that. The size of the shaft of the motor also influenced the size of the hole drilled in the bottom of the shaft as well.

Support strength of reservoir base: The analysis initially changed the design to a smaller thickness of the walls, but the entire design changed to folded sheet metal after the part sizes were determined to be too large to go through the manufacturing process.

Horsepower of lifter: The horsepower of the lifter itself did not change the design of the lifter. After researching the motors the dimensions changed the size of the offset mechanism and the lifter arm so that the lifter would not interact with the ground but still lifted the petri dishes the required amount.

Angle of incline, space needed, and length of lid opening rail: The rail was determined experimentally. Analysis greatly changed the shape of the rail. Dozens of trials were conducted to the rail in an attempt to create the action of the petri dish lid opening without the base also getting caught on the rail. The shape was almost entirely experimentally created.

Fin thickness for separating plate column: The thickness minimum found analytically did not greatly affect the design. The size and cost of material available was a greater influence. Also, even though the thickness could have been significantly smaller, we did not want there to be too much room in the housing for the dishes to rattle around and ruin the plating process.

### 5.2.6 Summary of code and standards and their influence. Similarly, summarize the relevant codes and standards identified and how they influence revision of the design.

The standards of the lab the client operated from was more influential on the design than codes. This makes sense since the codes are the legal bare minimum. Several of the standards of the lab changed the design. One of the standards stated that the fume hood could not contain the device for more than 24 hours at a time. The design must then allow for it to be portable and easy to store. For this we made the device separate into three parts that would then be easier to lift, maneuver, and store. This did not greatly change the design since there were basically four main parts to the design. It was mainly a problem for the electronics that would need to be easily detached and reattached whenever the user would want to use the machine.

There was also a standard about electrical devices that required us to have the electronics off the ground in case there was a leak in the device or liquid residue in the fume hood. We did this by creating a controller box that would hold the electronics slightly above the ground and the top should also help shelter the electronics in case of a leak in the reservoir.

## 5.3 Risk Assessment

### 5.3.1 Risk Identification

Two main risks have been identified in this product. First, the entire product needed to be sanitary - which resulted in a metal (stainless steel or aluminum) dominated design. By the end of production, it was evident that because of the geometric complexities in assembly, many sharp edges are present. These edges can be mitigated by a coating of silicone or some other adhesive that can soften and cover up these edges for pain-free handling. The second risk comprises of a few operational risk. In filling Petri Dishes, the conveyor system (while under its current design) needs to be tolerated tighter than the tools used to create it are capable of. This risk can be remedied by creating the system out of materials with high elasticity to gently push the dishes into their allocated spots, as well as using a CNC machine rather than the manual tools utilized. Two more operational risks are dispensing petri dishes one at a time and restacking petri dishes - both of which are unstable and need to be redesigned to constrain movement to only allow vertical motion.

Other minor risks include: the outer shell being able to handle the full weight of its contents, deformation of the inner fins separating stacks of filled Petri Dishes, heat loss of the stored agar solution, and placement of individual parts (by client) to match overall assembly specification (by designers).

The risk associated with the project were the following:

- Reliability of the part vendors
- Shipping time period for parts
- Machinability of special treated metals
- Limited budget of \$400
- Limited schedule availability to construct prototype



- Meeting expectation goals for initial prototype day

### **5.3.2 Risk Analysis (This is based on your project engineering analysis. Tools include simulation, happiness equations, calculation by hand or with SolidWorks, MATLAB, etc.). Discuss risk as it pertains to your performance specification, cost, and schedule**

The first main risk required some mathematical analysis that were beyond the scope of any one team member's education - as a result, the proposed course of action was "guess and check". The team would create a design that seemed feasible, observe the results, and make adjustments accordingly. Unfortunately, deforming the metal in minute concentrated amounts proved difficult, and in the end, the conveyor system "lifter" (see CAD Drawings) was not sculpted adequately. Other aspects of the design were analyzed by running the animation software through CAD in order to determine the degrees of freedom that each part could experience. Simplification of the software in the form of assumed constraints that could not actually be implemented falsely confirmed design accuracy.

### **5.3.3 Risk Prioritization**

In order of prioritized risks from most crucial to least crucial are: operational risks, heat loss placement of individual parts, handling, fin deformation, and weight handling. At the lower end of the spectrum, the team had little worry about the internal weight handling and deformation characteristic of our products - as our equations showed that the handled weight of very light-weight Petri Dishes were not going to remotely affect steel, aluminum, or the 3-D printed material. Handling was also a semi-small issue since there was a very simple solution. However, the operational risks do not have a real solution as of now and pose the greatest risk. Fixing these risks will require further design and testing to ensure the desired accuracy.

## 6 Working prototype

### 6.1 A preliminary demonstration of the working prototype (this section may be left blank).

The following is a link towards the preliminary demonstration of the working prototype.

<https://youtu.be/LLf9WxOxebI>

### 6.2 A final demonstration of the working prototype (this section may be left blank).

The following is a link towards the final demonstration of the initial prototype.

[https://youtu.be/z4Kd\\_hD-mmw](https://youtu.be/z4Kd_hD-mmw)

### 6.3 At least two digital photographs showing the prototype



Figure 4: The assembly of all parts of the machine interconnected for use in pouring petri dishes. (above)



Figure 5: The assembly of all of the machine's parts separated for easier manipulation and storage. (above)

**6.4 A short video clip that shows the final prototype performing**

**6.5 At least four (4) additional digital photographs and their explanation**



Figure 6: The door open for the empty petri dishes to be inserted before the process begins both up close (above) and at a distance (below, Figure 5) to see how the parts interact.



Figure 7





Figure 8: The rail has lifted the lid of the petri dish high enough for the proximity sensor to stop the conveyor belt and start the pinch valve sending agar solution into the opening. (above)

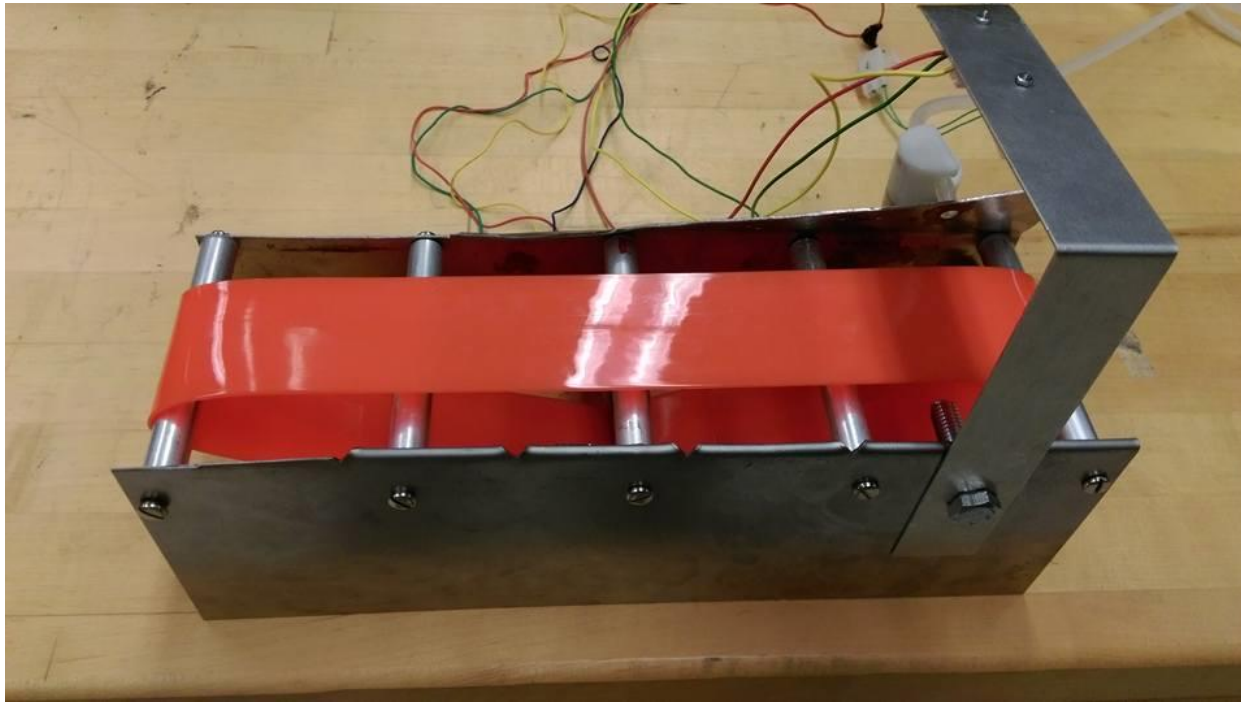

Figure 9: A closer view of the conveyor belt by itself to better see its components. (above)



## 7 Design documentation

### 7.1 Final Drawings and Documentation

**7.1.1** A set of engineering drawings that includes all CAD model files and all drawings derived from CAD models. Include units on all CAD drawings. See Appendix C for the CAD models.

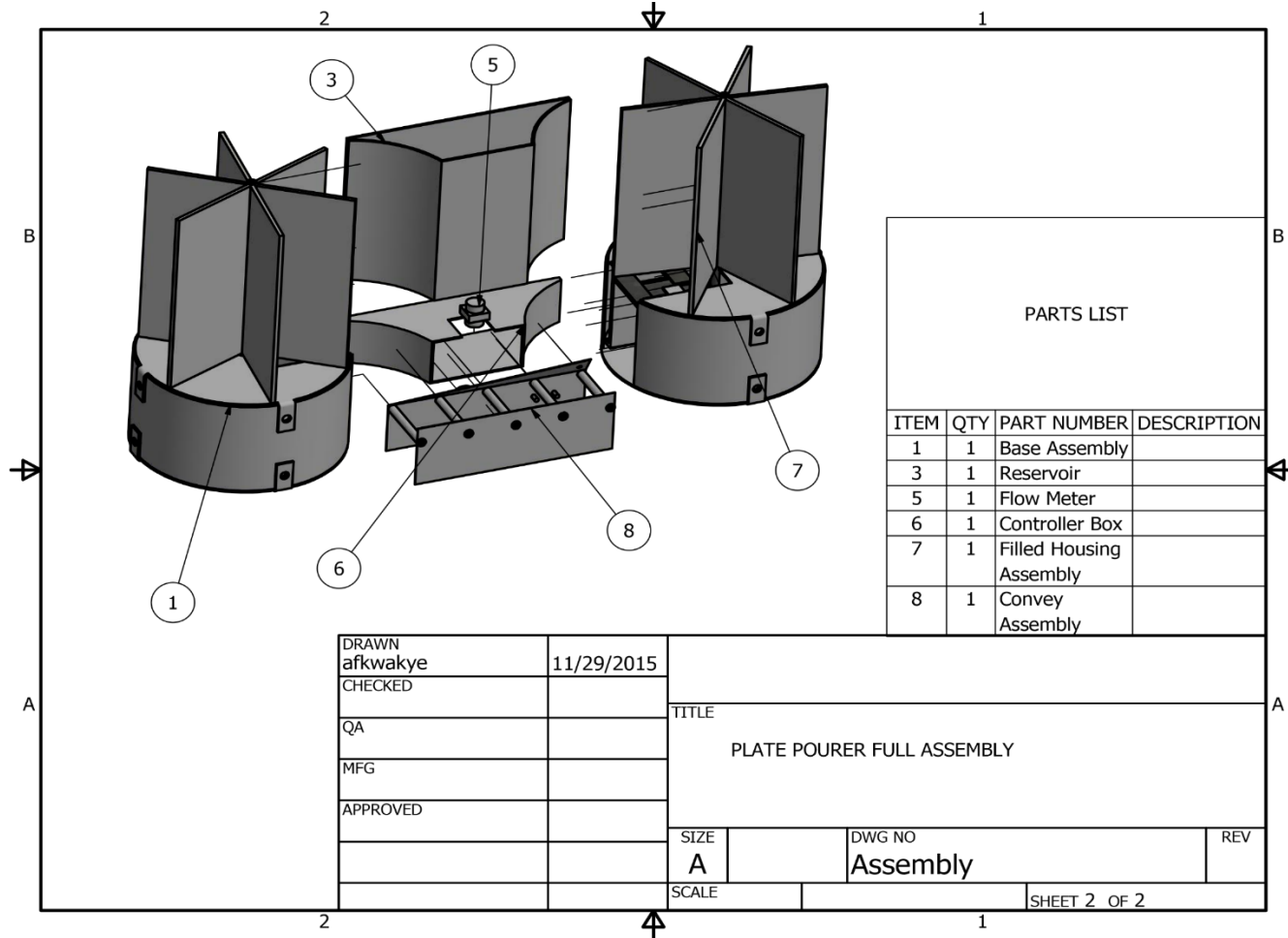

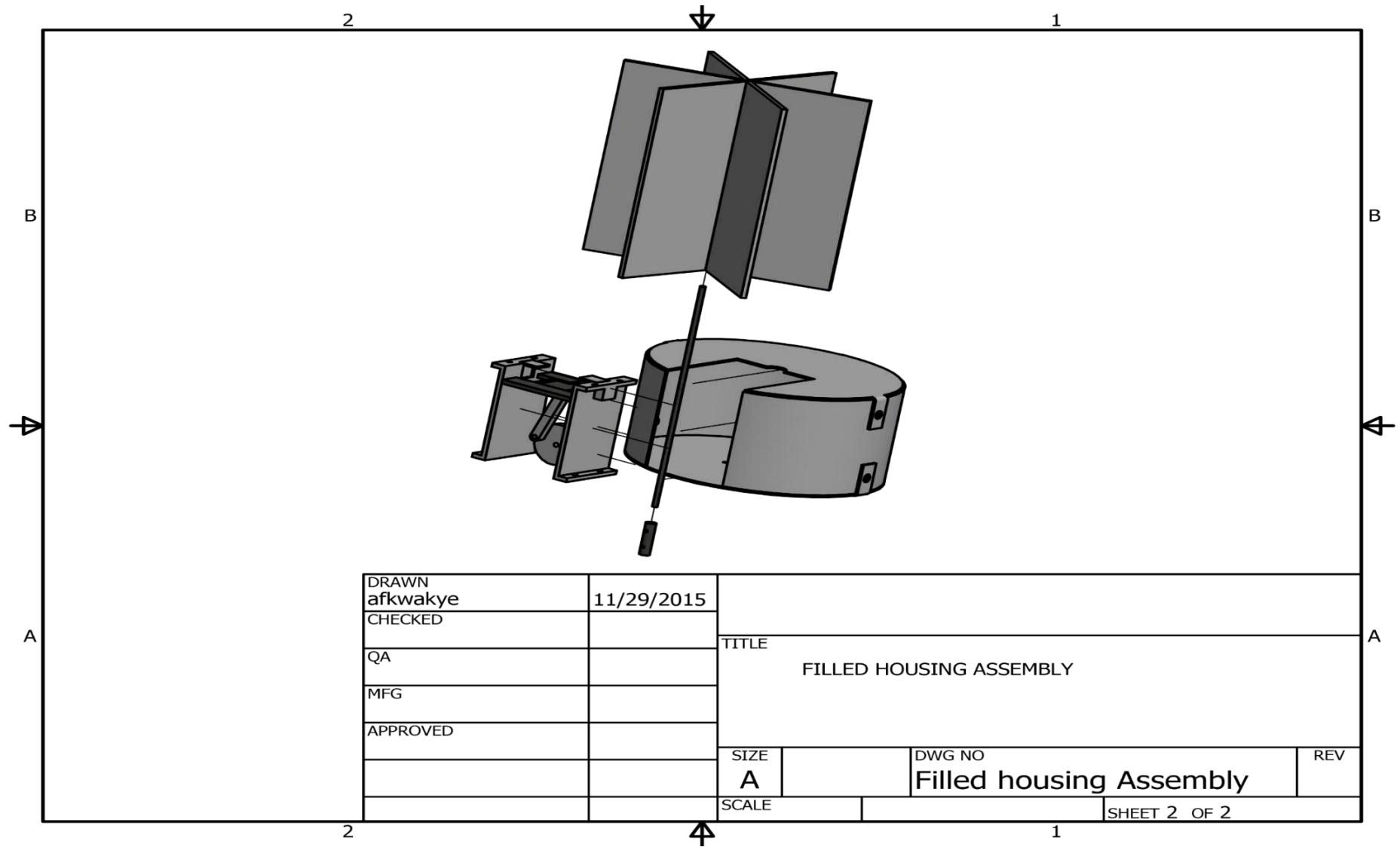

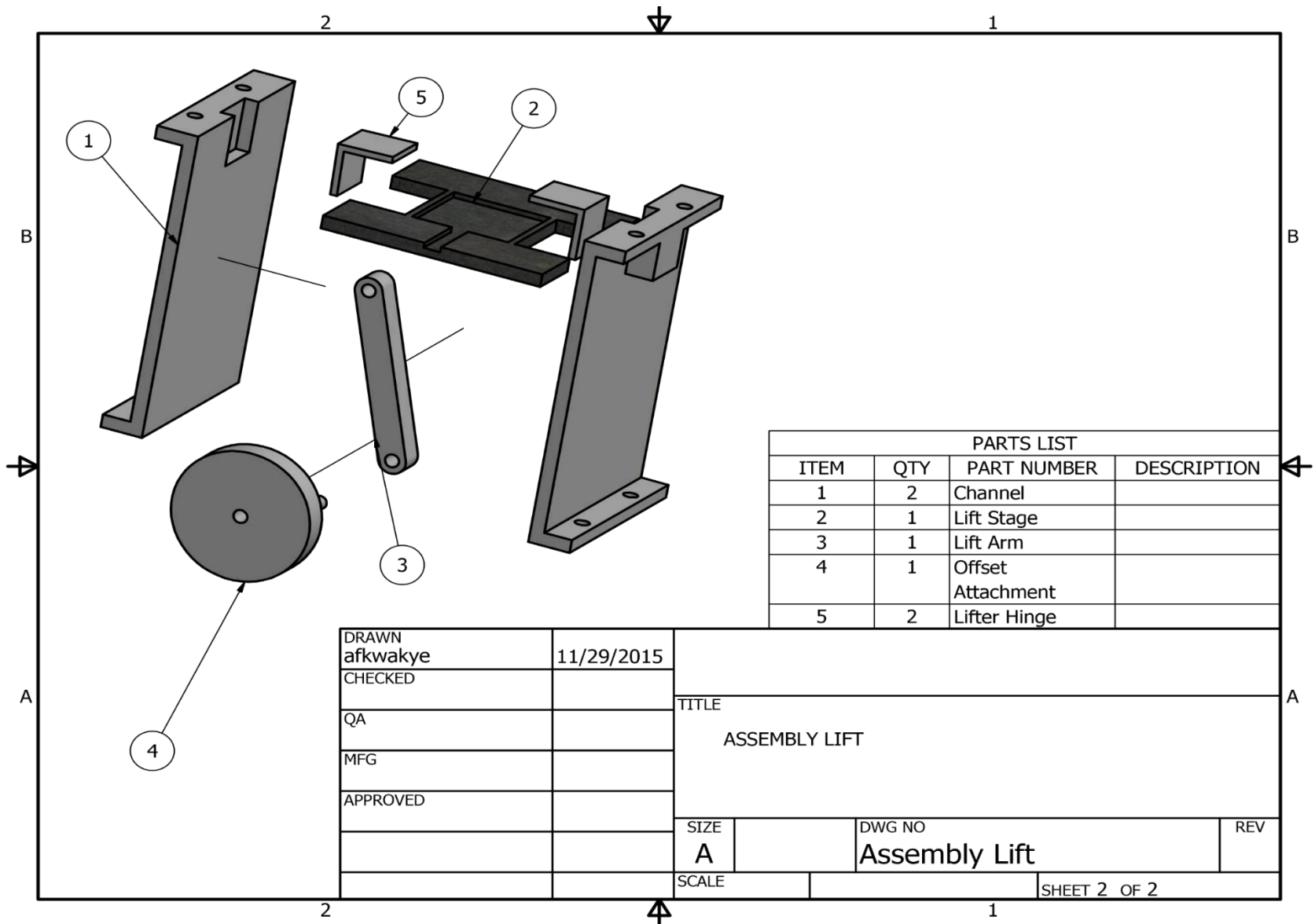

PARTS LIST			
ITEM	QTY	PART NUMBER	DESCRIPTION
1	2	Channel	
2	1	Lift Stage	
3	1	Lift Arm	
4	1	Offset Attachment	
5	2	Lifter Hinge	

DRAWN	afkwakye	11/29/2015
CHECKED		
QA		
MFG		
APPROVED		

TITLE		
ASSEMBLY LIFT		
SIZE	DWG NO	REV
A	Assembly Lift	
SCALE	SHEET 2 OF 2	

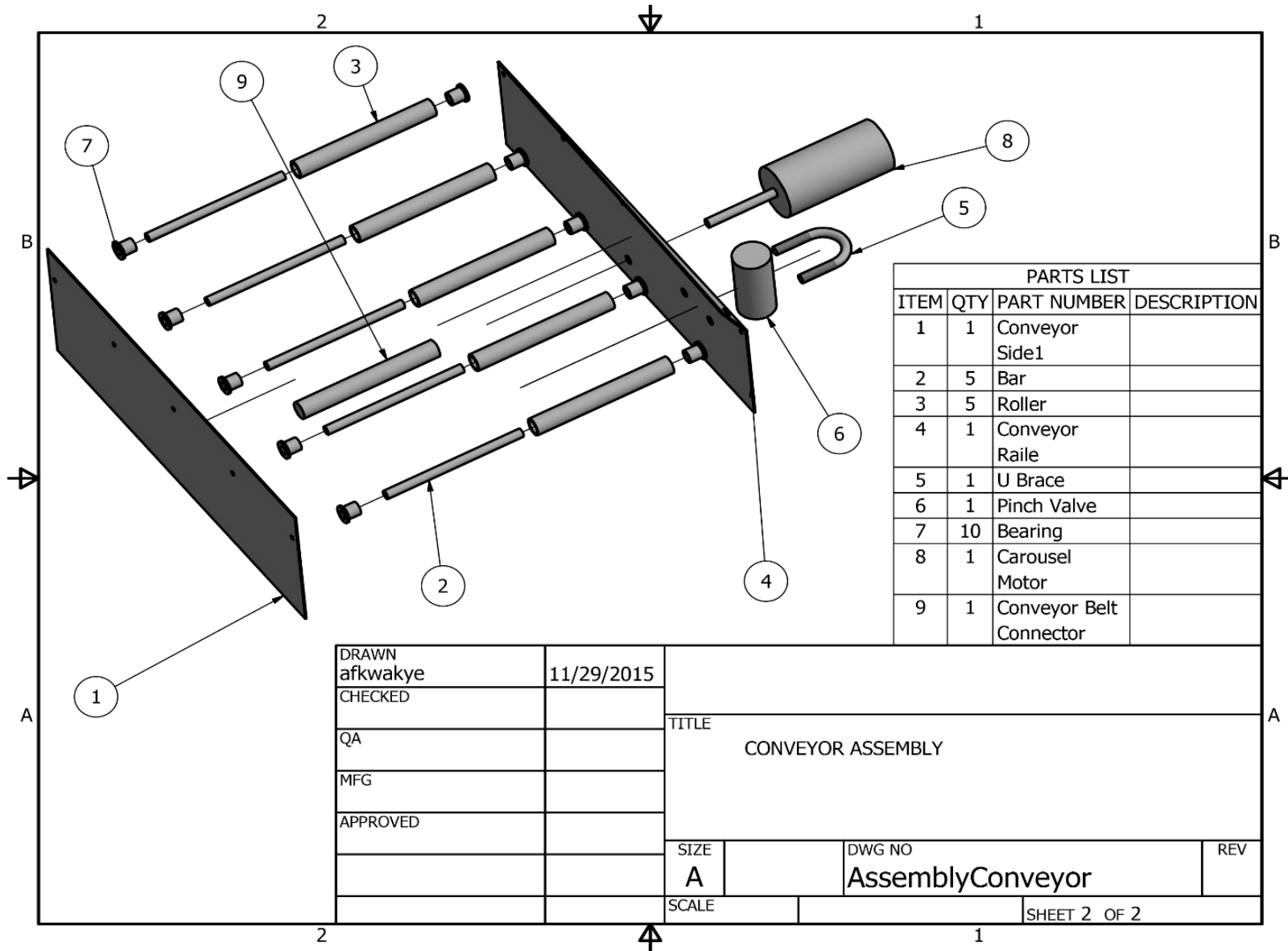

PARTS LIST			
ITEM	QTY	PART NUMBER	DESCRIPTION
1	1		Conveyor Side1
2	5		Bar
3	5		Roller
4	1		Conveyor Raile
5	1		U Brace
6	1		Pinch Valve
7	10		Bearing
8	1		Carousel Motor
9	1		Conveyor Belt Connector

DRAWN afkwakye	11/29/2015	TITLE CONVEYOR ASSEMBLY		
CHECKED				
QA				
MFG				
APPROVED		SIZE A	DWG NO AssemblyConveyor	REV
		SCALE		SHEET 2 OF 2

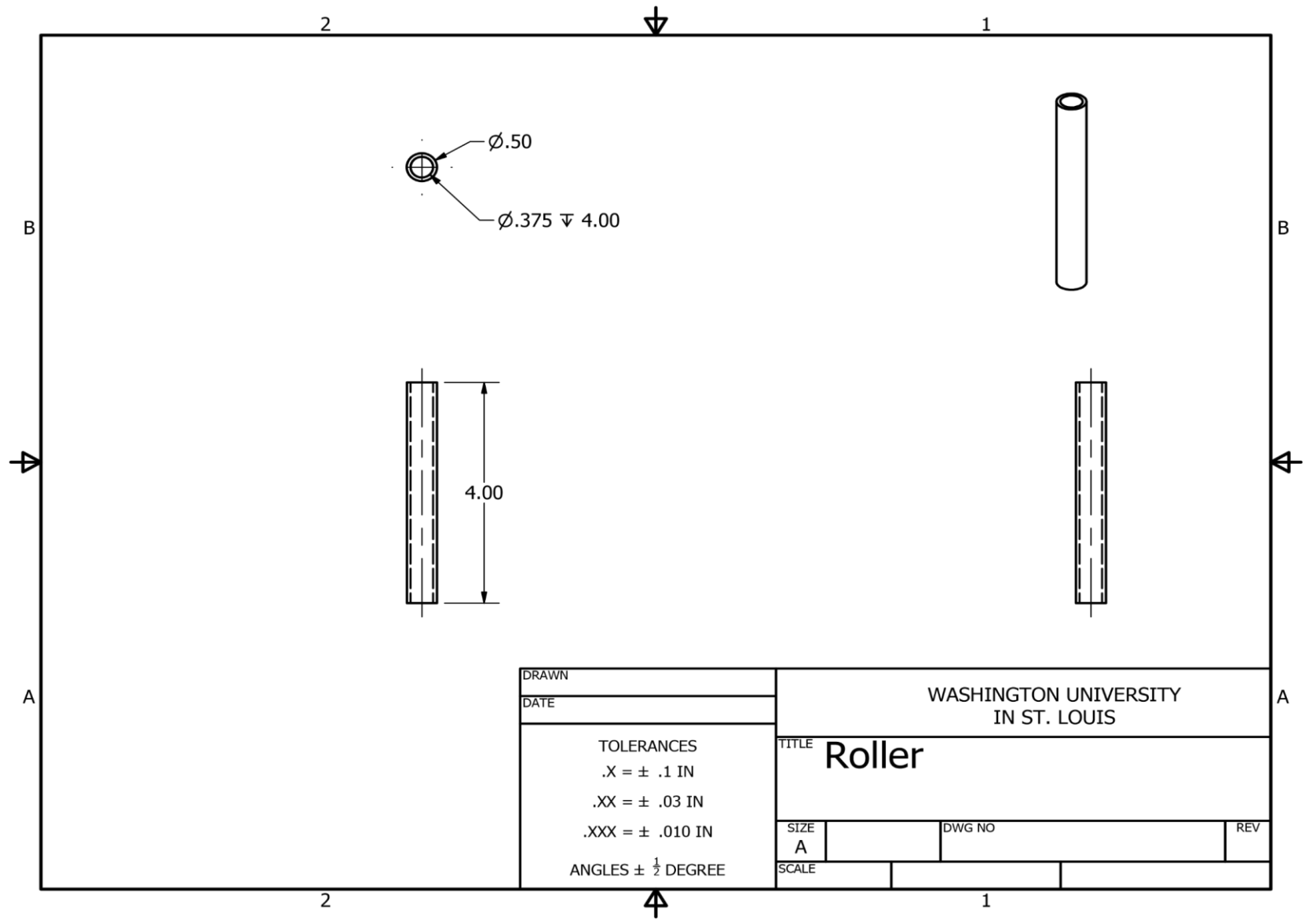

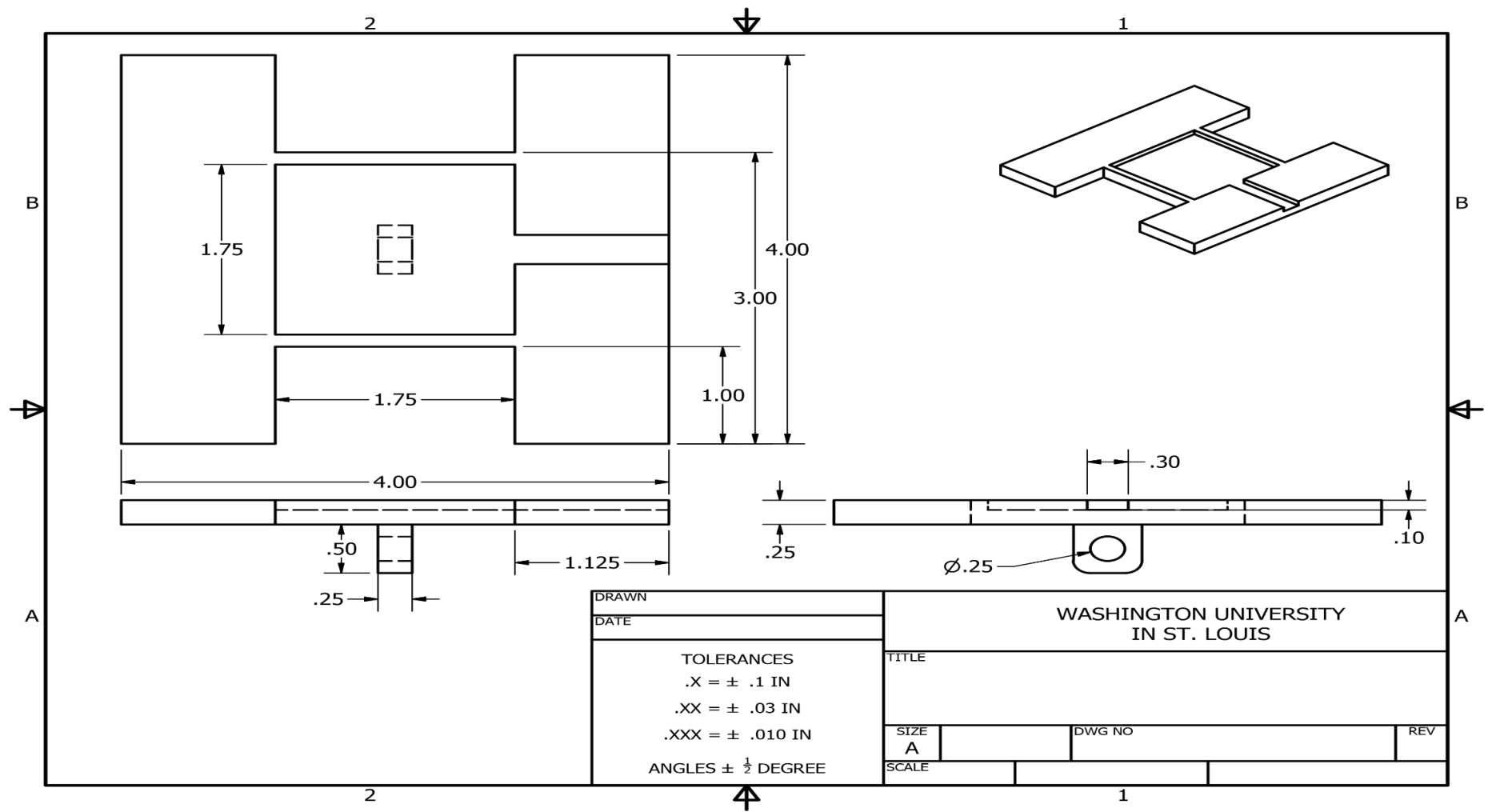

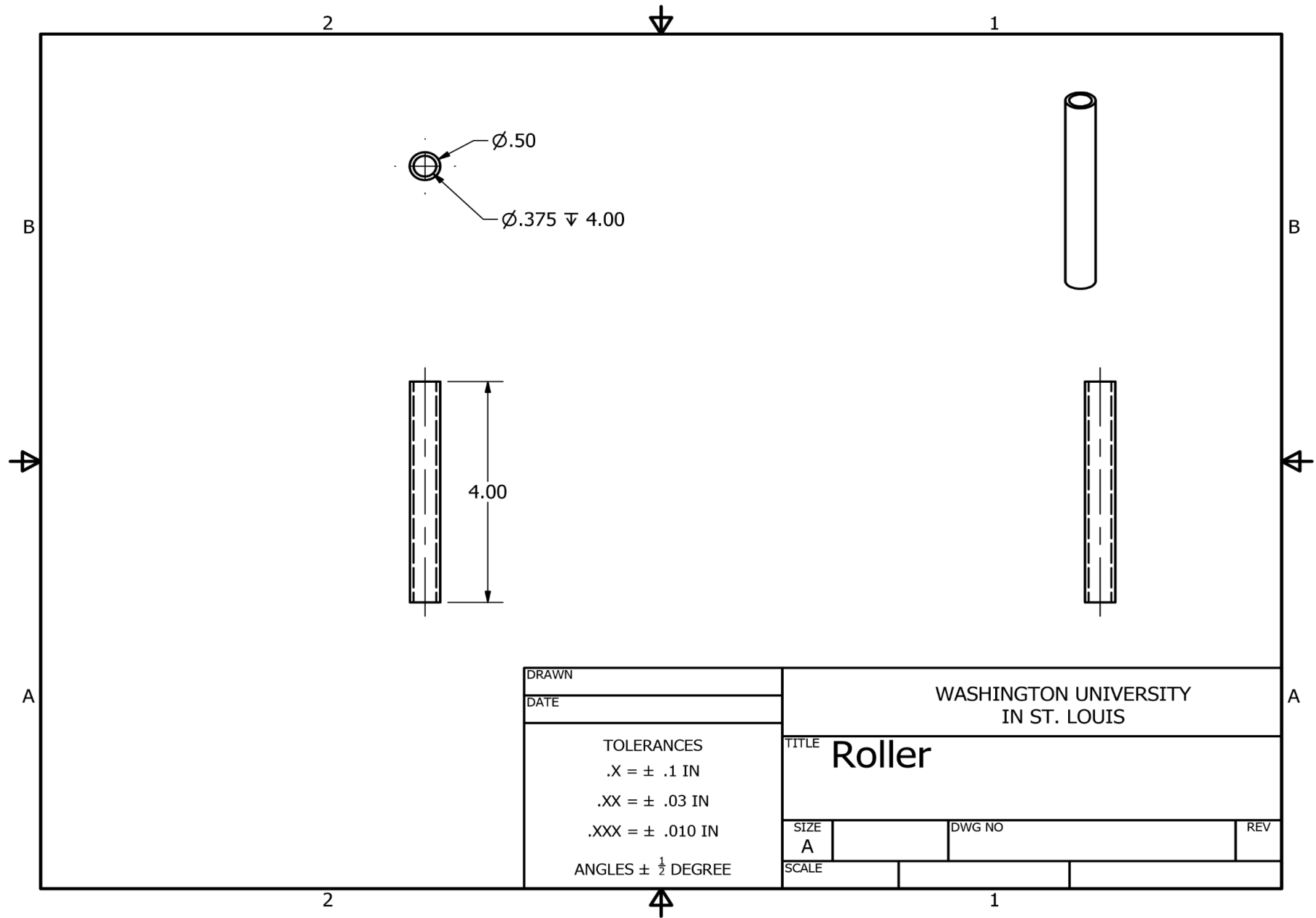

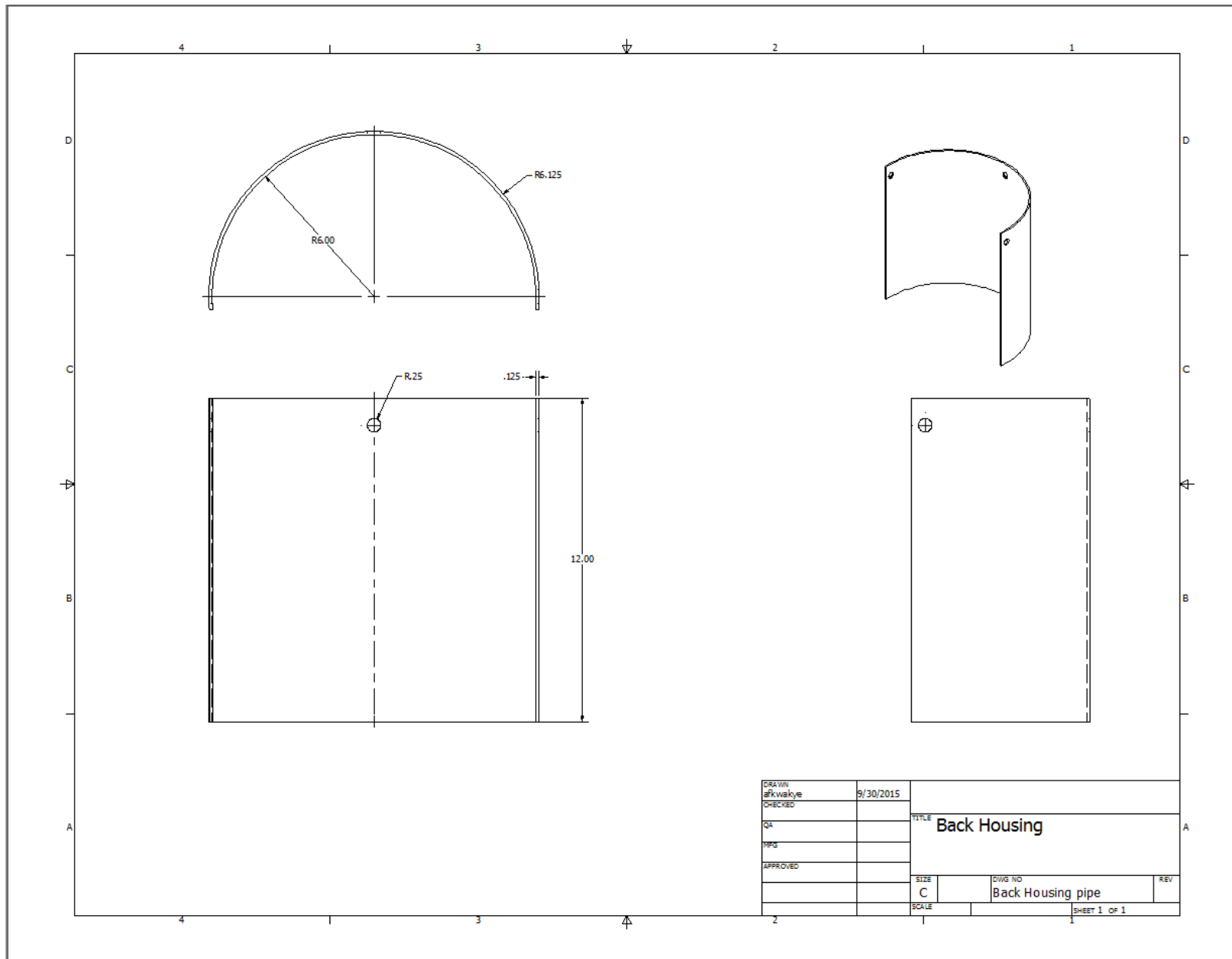

DRAWN	afk.wakye	9/30/2015		
CHECKED				
QA			TITLE Back Housing	
MFG				
APPROVED				
			SIZE C	DWG NO Back Housing pipe
			SCALE	REV
				SHEET 1 OF 1



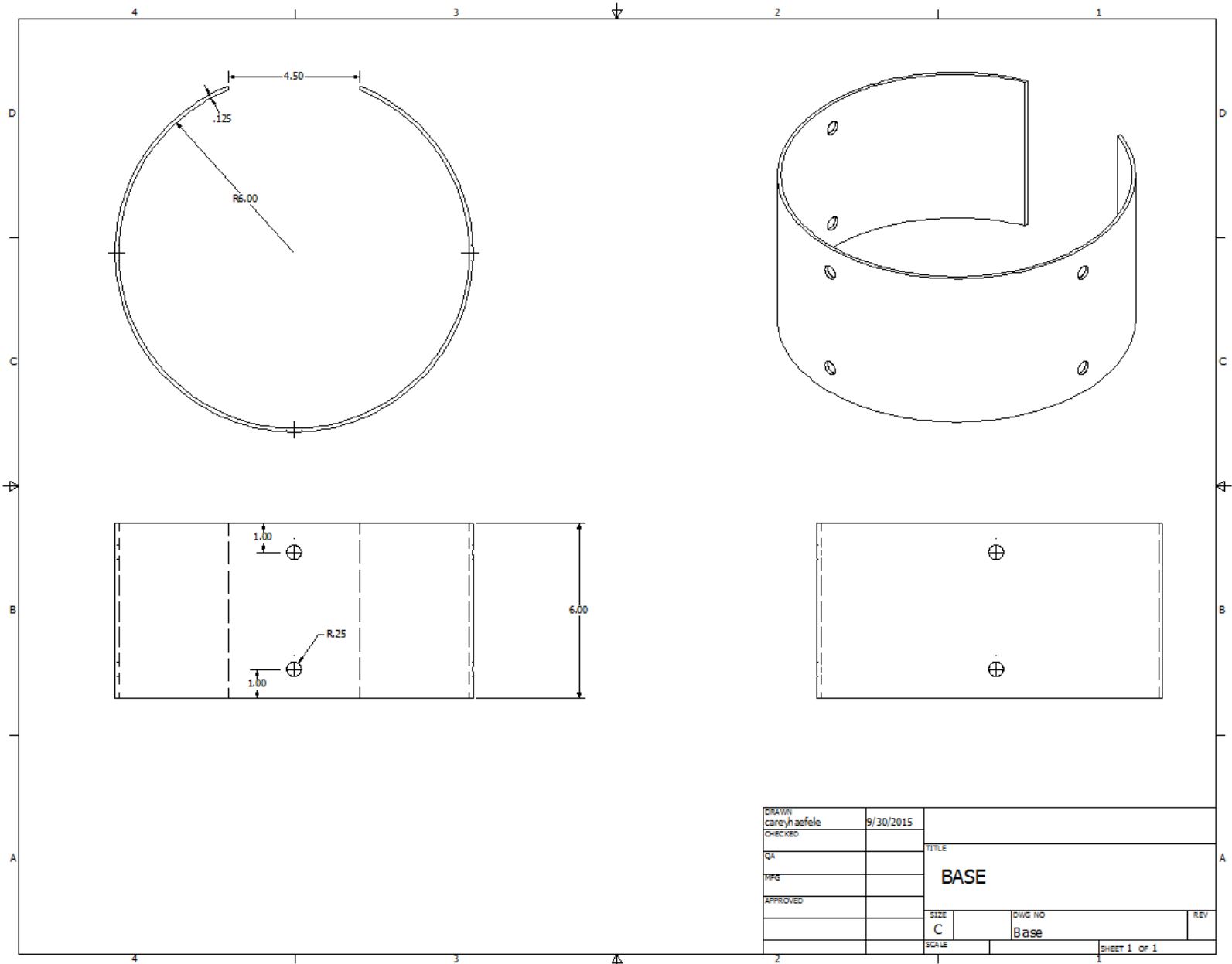

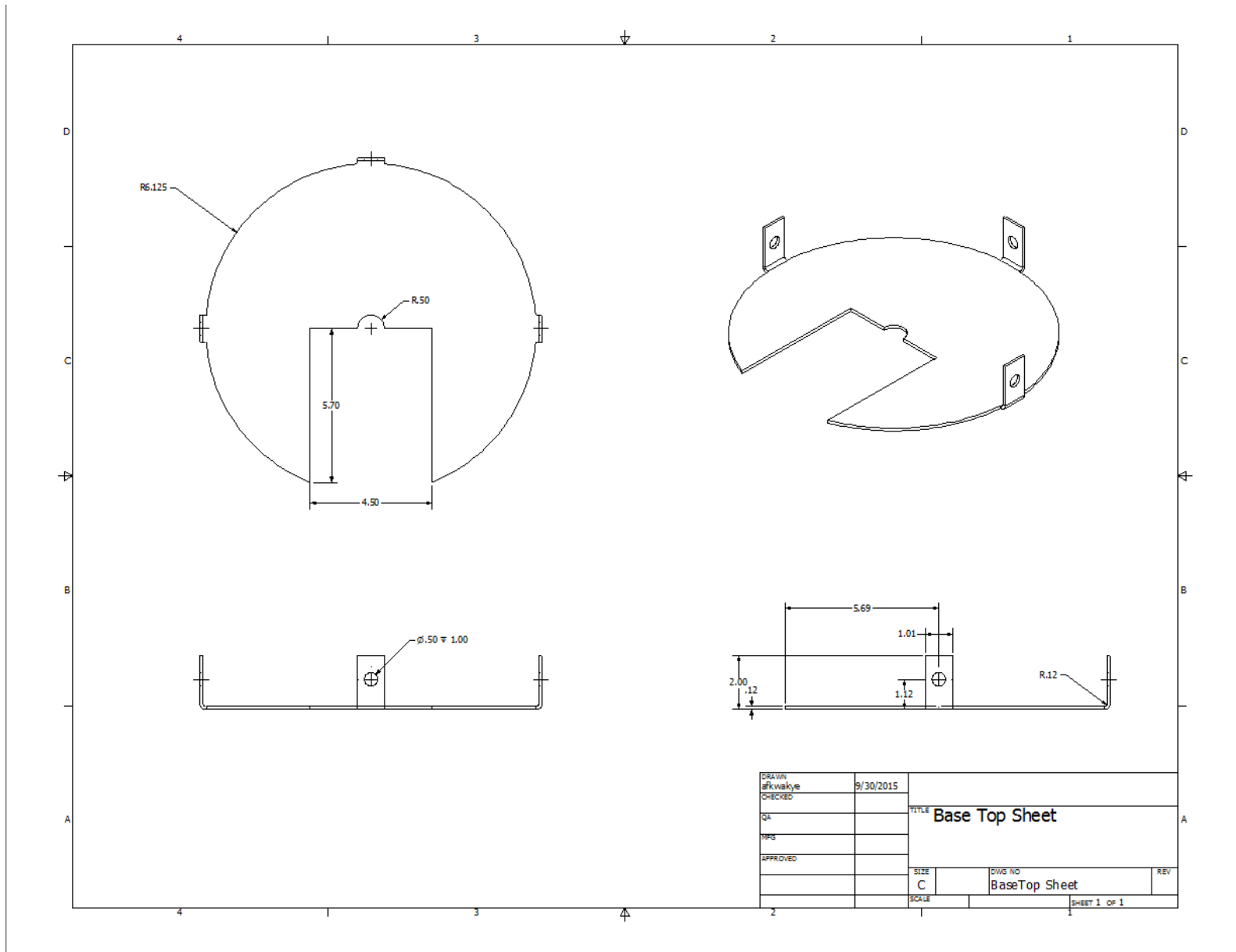

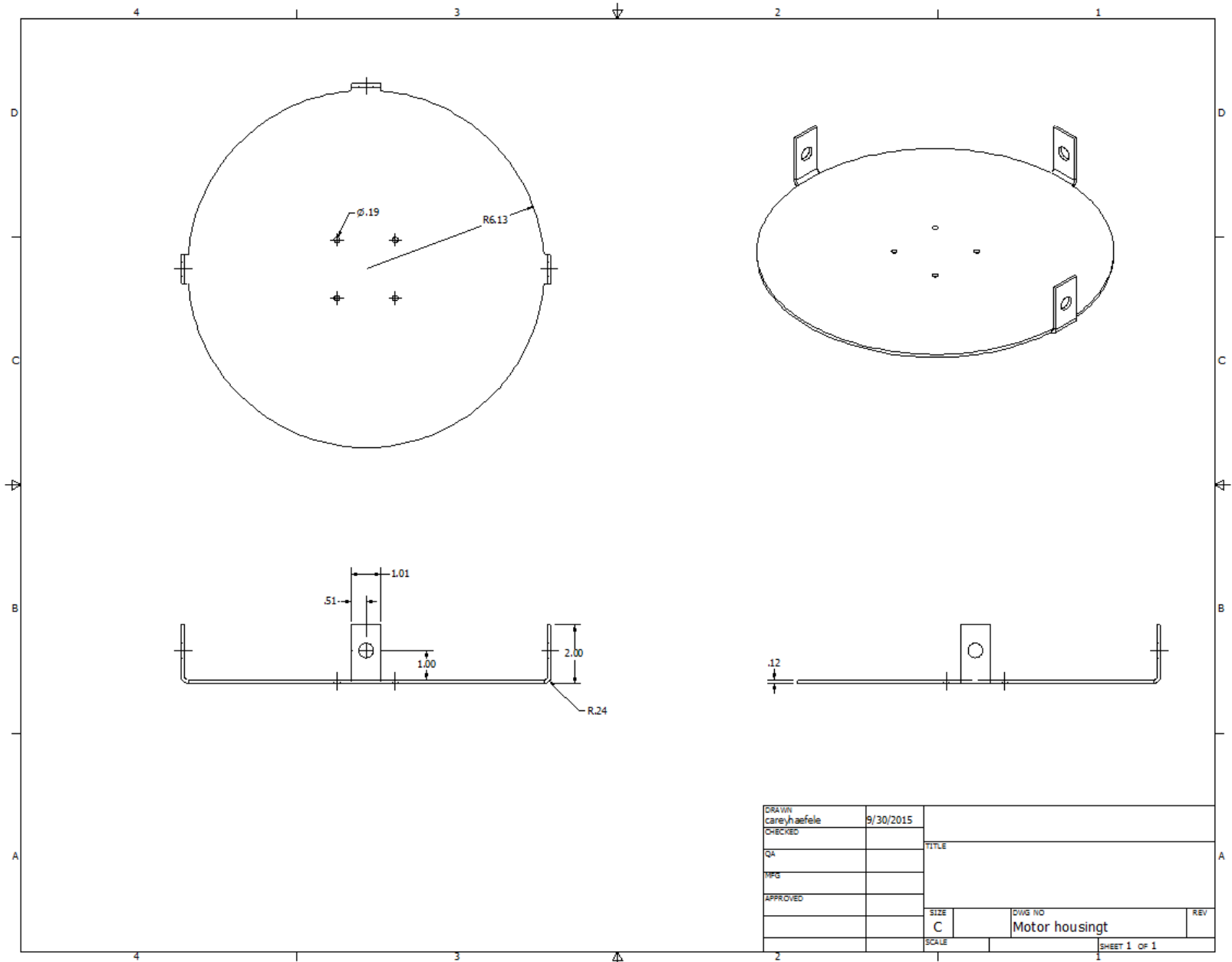

DRAWN careyhaefele	9/30/2015		
CHECKED		TITLE	
QA			
MFG			
APPROVED			
		SIZE C	DWG NO Motor housingt
		SCALE	REV
			SHEET 1 OF 1

### 7.1.2 Sourcing instructions

Part	Manufacturer	Parts Number	Quantity	Price per Quantity (\$)	Total Price	Delievered
12'' x 60'' Galvanized Round Sheet Metal Pipe	Home Depot	SM-3060GR 12	1	32.17	32.17	Y
4'x5' 16 gauge Plain Steel Plate	Sharpio		1	31.5	31.5	Y
Labor Cuts	Sharpio		1	3	3	Y
Low-Carbon Steel Rod 1/2" Diameter, 3' Length	McMaster Carr	8920K155		7.72	0	Y
1/4" steel Rod	Sharpio		1	6	6	Y
Force Sensitive Resistor - Square	Sparkfun	SEN-09376	1	7.95	7.95	Y
G 3/4 Water Flow Sensor	GarageLab		1	13.9	13.9	Y
Infrared Proximity Sensor	GarageLab	SEN-00242	2	13.95	27.9	Y
Stepper Motor Drivers	Amazon	SX09402	3	7.14	21.42	Y
Stepper Motors	Amazon	RR-ST-MTO-DI	2	27.95	55.9	Y
Pinch Valve	Ebay		1	25	25	Y
Plastic Fins	Tap Plastic		1	31.6	31.6	Y
Arduino Starter Kit	Arduino		1	24.95	24.95	Y
Relay Piece	RadioShack		1	4	4	Y
Door Latches	Home Depot		2		7.61	Y
Belts for Conveyor 2-2in. Wide / 5 ft. long	McMaster Carr		2	5.16	25.8	Y
Nylon Bushings	McMaster Carr		6	0.52	3.12	Y
Stepper Motor	Amazon		2	27.95	55.9	Y
				Spent	<b>377.72</b>	
				Available	22.28	

- Separator: Creates 5 distinct stacks of petri dishes to dispense and restack
- Base Assembly (Filled Housing): Holds the lifting mechanism and the stepper motor that will spin the separator as well as the attached shaft
- Base Assembly (Initial Housing): Holds a stepper motor that will spin the separator as well as the attached shaft
- Shaft: Spins the Separators
- Stepper Motor: Used for precise movement in several noted cases
- Assembly Lift
  - o Channel 1: Holds the lifting mechanism in place from the right
  - o Channel 2: Holds the lifting mechanism in place from the left
  - o Stage: Holds a force sensor and will push petri dishes into the filled housing
  - o Lift Arm: Link that will push the stage in the z-direction
  - o Offset Attachment: Circular plate attached to a stepper motor that will rotate the lift arm
  - o Lifter Hinge 1: Prevents Petri dishes from falling below the assembly from the left
  - o Lifter Hinge 2: Prevents Petri dishes from falling below the assembly from the right
- Assembly Conveyor
  - o Carousel Motor: Stepper Motor that will rotate the conveyor system
  - o Conveyor Belt Connector: Attached to the carousel motor to move the conveyor belt
  - o Roller – Outer Layer attached to the conveyor belt
  - o Conveyor Belt – Conveyor system belt
  - o Bearing – Separates the attached Bars from the Rollers allowing the rollers to spin somewhat frictionless
  - o Bar – Precisely locates belt locations
  - o Conveyor Side 1: Provides a wall for petri dishes to be pushed against
  - o Conveyor Rail: Lifts the top lid off of Petri Dishes to pour agar from
  - o Pinch Valve: Controls the flow of agar
  - o U Brace – Holds the Pinch Valve in place
- Reservoir: Holds 4 liters of agar
- Controller Box – Houses most electronics and provides a base for the reservoir

## 7.2 Final Presentation

### 7.2.1 A live presentation in front of the entire class and the instructors (this section may be left blank)

The following is a link to the final live presentation.

<https://youtu.be/asWyLJl54DQ>

### 7.2.2 A link to a video clip version of 1

The following is a link to the final presentation.

<https://youtu.be/ehc2Hwdbmx8>

## 7.3 Teardown



Engineering  
Teardown.pdf

## 8 Discussion

### 8.1 Using the final prototype produced to obtain values for metrics, evaluate the quantified needs equations for the design. How well were the needs met? Discuss the result.

The following six metrics have changed from the initial quantified need predictions: metrics one, two, three, five, eight, and thirteen. The first metric, AP opens and closes Petri Dishes, has not been accomplished with reliable repeatability. The second and third metrics, "AP can stack Petri Dishes", and "Fills Petri Dishes in ascending order", are reliant on the accuracy of our "lifter" mechanism and have the same issue with metric 1. Metric five, "Heat Agar Solution", was appropriated after consulting with the client. The interpreted information is now that the solution will retain its temperature if Petri Dishes are stacked within the hour. Therefore, the need for metric five has been eliminated. "Minimizes splashes", metric eight, is reliant on the lifter mechanism as well as the conveyor system and therefore has not been accomplished. Though the team remained within the allocated budget, metric thirteen, "Cost is Reasonable", did not take into account the cost of scrounged parts and material modifications which would put the design beyond the allotted financial constraints.

### 8.2 Discuss any significant parts sourcing issues? Did it make sense to scrounge parts? Did any vendor have an unreasonably long part delivery time? What would be your recommendations for future projects?

Most issues in sourcing parts originated out of a communication issue between the team and the university provided parts ordering system. Several parts such as bearings, conveyor belts, and motors came late or were simply not ordered until the team had to expressly ask post a prolonged waiting period. Consulting the professors, the issue appears to be the file system for ordering parts. Said system can be opened by anyone - which changes the status of said order from unread to read. At that point, the part order should immediately be placed; however, since the files can be opened by anyone often times there was a preliminary reader who would not place the order - causing confusion and a lack of order placements. In future projects, this system should be altered so that a user can mark a file as "resolved" when an order has been placed.

Scrounging parts was useful in a variety of cases where material selection was chosen arbitrarily and had reasonable variability. The majority of the "lifter" mechanism was scrounged as well as L-bracket braces needed to secure motors.

Assuming future projects are also mechatronic-heavy, teams would benefit greatly from adding Garage Lab (a sensor/actuator vendor) to the list of available vendors (for express shipping).

### **8.3 Discuss the overall experience:**

#### **8.3.1 Was the project more or less difficult than you had expected?**

The project was much more difficult than expected. Designing and creating the mechanical parts was about as hard as expected, but there were complications when it came to researching parts and creating the electrical circuits. Researching parts that would produce the final product we wanted as well as fit the budget required a longer amount of time and effort than we expected. Problems also occurred when we tried to purchase some of our items and the order did not go through. The electronics required us to learn a lot about the Arduino in a small amount of time and the material was not the easiest to understand making it more difficult than initially thought. We had to use many different resources in order to have a working prototype in time and the electronics took more time to set up than expected.

#### **8.3.2 Does your final project result align with the project description?**

The final product does complete many of the points project description it does not completely align with the description. The machine can handle the amount of petri dishes needed to be plated in an hour but the lid removing device is not perfect and so occasionally the agar would be spilled on the conveyor belt. The machine also has the potential to slosh the agar solution around too much and ruin the plating.

#### **8.3.3 Did your team function well as a group?**

Our team worked reasonably well together. All members were involved in the concept selection and, though there were debates on the approach to some of the aspects of the final design, there was always an agreement at the end as to what the process should be.

#### **8.3.4 Were your team member's skills complementary?**

Our team's skills were heavily skewed towards manufacturing. We all had a significant knowledge of how to use the machine shop but were limited in other areas. We did have a small variation of some skills such as concept design. One of us was better at concept drawings while another was better at the happiness equations.

#### **8.3.5 Did your team share the workload equally?**

Based our large overlap of skills it was difficult to spread the workload out evenly in some areas. We all worked on the actual manufacturing of the machine. We separated the smaller components of the device for each of us to research the correct materials and parts to purchase for it. Overall, we shared the workload evenly.

#### **8.3.6 Was any needed skill missing from the group?**

The only skill missing that made a significant difference in our project was the lack of someone with knowledge of electronics or Arduino. We spent a long time figuring out how to operate the Arduino and then spent an even longer amount of time researching the correct way to set up the circuits for the sensors and actuators to work.

### 8.3.7 Did you have to consult with your customer during the process, or did you work to the original design brief?

We worked off of an interview we had with our client. Though he agreed with most of the criteria he added a small amount of requirements and rejected some of the extra capabilities of the original design brief.

### 8.3.8 Did the design brief (as provided by the customer) seem to change during the process?

The design brief did not seem to change during the designing process. Once he set his requirements and we established which were the most important the design was made to fit those criterion as well as possible.

### 8.3.9 Has the project enhanced your design skills?

Yes, we all believe that our design skills have dramatically increased based on this project. This project has enlightened us about many of the processes necessary to complete a project like this that are easily overlooked.

### 8.3.10 Would you now feel more comfortable accepting a design project assignment at a job?

Yes, we would all feel much more comfortable being placed on a team that designs a project at work. This project was very good at showing students every process that is necessary to finish a project and how those processes interact.

### 8.3.11 Are there projects that you would attempt now that you would not attempt before?

For the most part, we believe that this project has helped us to better understand the process.

## 9 Appendix A - Parts List

Part	Manufacturer	Quantity
12" x 60" Galvanized Round Sheet Metal Pipe	Home Depot	1
4'x5' 16 gauge Plain Steel Plate	Sharpio	1
Labor Cuts	Sharpio	1
Low-Carbon Steel Rod 1/2" Diameter, 3' Length	McMaster Carr	1
1/4" steel Rod	Sharpio	1
Force Sensitive Resistor - Square	Sparkfun	1
G 3/4 Water Flow Sensor	GarageLab	1
Infrared Proximity Sensor	GarageLab	2
Stepper Motor Drivers	Amazon	3
Stepper Motors	Amazon	2
Pinch Valve	Ebay	1
Plastic Fins	Tap Plastic	1



Arduino Starter Kit	Arduino	1
Relay Piece	RadioShack	1
Door Latches	Home Depot	2
Belts for Conveyor 2- 2in. Wide / 5 ft. long	McMaster Carr	2
Nylon Bushings	McMaster Carr	6
Stepper Motor	Amazon	2

## 10 Appendix B - Bill of Materials

Part	Manufacturer	Quantity	Price per Quantity (\$)	Total Price
12" x 60" Galvanized Round Sheet Metal Pipe	Home Depot	1	32.17	32.17
4'x5' 16 gauge Plain Steel Plate	Sharpio	1	31.5	31.50
Labor Cuts	Sharpio	1	3.00	3.00
Low-Carbon Steel Rod 1/2" Diameter, 3' Length	McMaster Carr	1	7.72	7.72
1/4" steel Rod	Sharpio	1	6.00	6.00
Force Sensitive Resistor - Square	Sparkfun	1	7.95	7.95
G 3/4 Water Flow Sensor	GarageLab	1	13.90	13.90
Infrared Proximity Sensor	GarageLab	2	13.95	27.90
Stepper Motor Drivers	Amazon	3	7.14	21.42
Stepper Motors	Amazon	2	27.95	55.90
Pinch Valve	Ebay	1	25.00	25.00
Plastic Fins	Tap Plastic	1	31.60	31.60
Arduino Starter Kit	Arduino	1	24.95	24.95
Relay Piece	RadioShack	1	4.00	4.00
Door Latches	Home Depot	2	7.61	7.61
Belts for Conveyor 2- 2in. Wide / 5 ft. long	McMaster Carr	2	5.16	25.8
Nylon Bushings	McMaster Carr	6	0.52	3.12
Stepper Motor	Amazon	2	27.95	55.9
			Spent	<b>385.44</b>
			Available	14.56

### 11 Appendix C - CAD Models

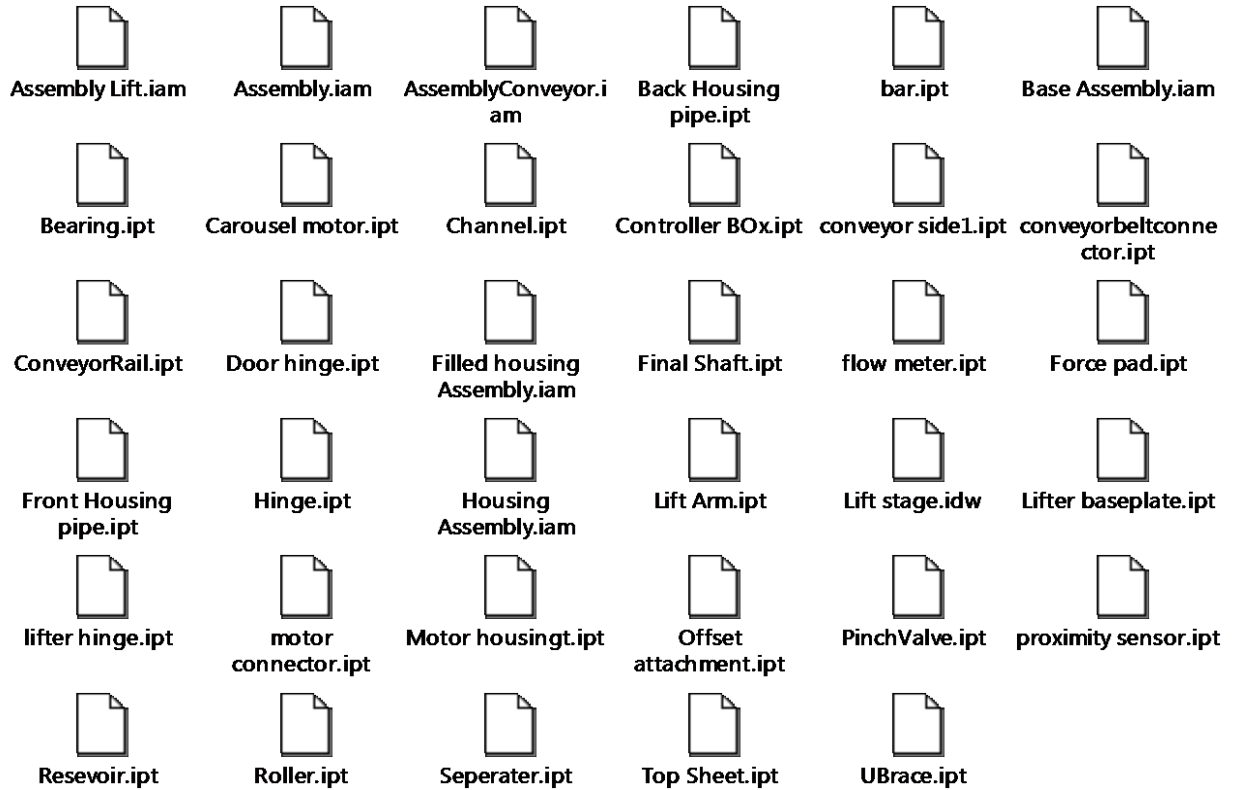

## 12 Annotated Bibliography (limited to 150 words per entry)

1. Biomed Design, Inc.,. 'Apparatus For Filling Petri Dishes'. 1984: n. pag. Print.

This device helped with the initial idea for the rail system that would lift the lid off of the petri dish while moving along a conveyor belt. This allows for the machine to not have a lid removing device but instead combines the action of moving the petri dish and removing the lid.

2. New Brunswick Scientific Co., Inc.,. 'Method And Apparatus For Filling Petri Dishes'. 1979: n. pag. Print.

This device helped with the initial concept of the two towers that held the petri dishes. This would allow the petri dishes to be stored both before and after the agar solution had been added. Our design used linear motion instead of rotational and so required two housings.